



BAMBI MAX BUCKET

Models 1518 – 3542

SERVICE MANUAL

2025B

BAMBI MAX BUCKET SERVICE MANUAL

Models 1518-3542

Version: 2025B

Part Number: 017006

Maintenance Level: Organizational (O)

PLEASE READ BEFORE USING.

This manual is applicable to the following models:

BBX1518 (# 007898)	BBX2226 (# 007901)
BBX1518S (# 013517)	BBX2226L (#019870)
BBX1821 (# 007899)	BBX2732 (# 007902)
BBX1821S (# 013518)	BBX2732S (# 013520)
BBX2024 (# 007900)	BBX3137 (# 017065)
BBX2024S (# 013519)	BBX3542 (# 007903)

PATENTS

AU2012201273

CA2770005

US9265977

Physical copies of this manual (# 005461) are available from SEI.

This manual is available on the SEI website.

Register for manual update notifications at bambiupdate@sei-ind.com.

This manual is based on information that was available at the time it was printed and may not be applicable to products received before the issue date and customized items.

SEI INDUSTRIES LTD.

7400 Wilson Avenue

Delta, B.C. Canada

V4G 1H3

Phone: (604) 946-3131

Fax: (604) 940-9566

E-Mail: seisales@sei-ind.com

Website: www.bambibucket.com

Revision Summary

Version	Release Date	Revision Description	Pages	App.
2020A	21-Jan-2020	<ul style="list-style-type: none"> • General Revision 	-	AW
2020B	25-Nov-2020	<ul style="list-style-type: none"> • General Revision • IVC 2 	-	AW
2021A	06-Apr-2021	<ul style="list-style-type: none"> • General Revision • PowerPack now upgraded to 28.8 VDC • Updated Section 6: Troubleshooting • Added Model BBX3137 • IVC Indicator revised 	-	AW
2021B	18-Jun-2021	<ul style="list-style-type: none"> • Guide Rod, Support Rod, & Attachment fasteners changed 	-	AW
2022A	03-Jan-2022	<ul style="list-style-type: none"> • General Revision • Added shell bracket assembly to Parts Section 	-	GN
2023A	01-Jun-2023	<ul style="list-style-type: none"> • Added screw torque • Clarified weight • Guide Rod, Support Rod, & Attachment fasteners changed 	44 47 71,76	MDT
2024A	14-Feb-2024	<ul style="list-style-type: none"> • Revised IDS Assy • Removed valve guard paint 	81 69,71	AS
2024B	13-Dec-2024	<ul style="list-style-type: none"> • Updated to new bracket design • Updated Warranty Section 	71-76 90	AS
2025A	27-Jun-2025	<ul style="list-style-type: none"> • IVC3 • Added 2226L • Added Cable Clip Assembly 	4, 21,75 - 84, 85	MDT AS
2025B	16-Oct-2025	<ul style="list-style-type: none"> • New IDS assembly 	81-83	AS

VALIDATION OF OPERATIONS DESCRIBED IN THIS MANUAL

The maintenance operations described in this manual have been checked in manufacturer's workshops by an exact carrying out of dismantling, reassembly, test and repair instructions which are detailed in this document.

These operations are those in use at the latest revision date of the document.

Table of Contents

Section 1: Introduction	1
Valve System	2
Section 2: Deploying the Bucket	5
Attaching to the Cargo Hook	5
Connecting Power	6
Longlines	7
Checking Tail Rotor Clearance.....	8
Instant Deployment System (IDS)	9
Section 3: Accessories	11
PowerFill Snorkel	11
Foam Injection Systems.....	12
Power Pack.....	14
Section 4: Making Adjustments	15
Adjusting Components.....	15
Section 5: Packing and Storage	17
Packing.....	17
Storage	20
Section 6: Troubleshooting and Maintenance	21
Troubleshooting	21
Maintenance Procedures	25
Section 7: Repair Assessment Guide	27
Overview of Repair Categories.....	27
Head Repair Criteria	28
Cables Repair Criteria.....	29
M-Straps/Top Chains Repair Criteria	30
IDS Hub Repair Criteria	31
Bucket Shell Repair Criteria	32
Section 8: Repairs	33
Rigging Repairs	33
Valve Repair and Replacement.....	39
Shell Repairs	50
Section 9: Specifications and Parts	57

Capacity and Weight Specifications	57
Bolt Torque Specifications	58
Parts	59
Section 10: Drawings	89
Section 11: Warranty	93

Section 1: Introduction

Section 1: Introduction

The Bambi MAX Bucket (Bambi MAX) is a collapsible firefighting bucket with a multiple drop valve. The multiple drop capability allows an operator to split the bucket load over several locations. It also allows the operator to adjust the amount of water carried in the bucket to match the lifting capability of the aircraft throughout its fuel cycle.

This manual provides information on the service and maintenance of Bambi MAX Bucket models 1518 to 3542. A separate Bambi MAX Bucket operations manual is also supplied which should be carried on-board the helicopter.

For your own protection, and for longer bucket life, always read the instructions and warnings. Ignoring these warnings could result in personal injury, bucket damage, or aircraft damage.

SEI Industries Ltd. offers complete parts supply and repair services for the Bambi MAX Bucket. For a repair facility in your area, please contact SEI. For maintenance and repair purposes, parts diagrams and descriptions are provided in this manual.

When you are ordering parts, please provide the model and serial number of your Bambi MAX Bucket as shown on the data tags located inside the bucket shell.



Section 1: Introduction

Valve System

Description

The Bambi MAX Bucket uses a tubular type valve with seals located on the top and bottom of the tube. When in the default closed position, the seals make contact with top plate and bottom ring of the valve assembly. When in the open position, the tube is raised allowing water to flow between the bottom of the tube and the base ring and then through the opening in the base ring.

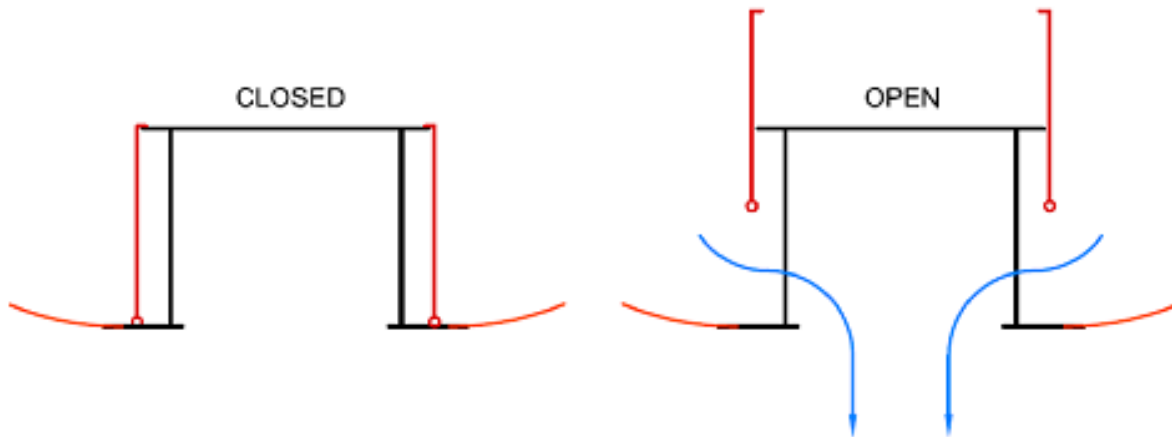

Movement of the valve tube is controlled by an actuator and drive cable system. The actuator is mounted on the top plate and consists of a drive motor, reduction gearing, and a cable drum. The cable drum can be rotated clockwise or counter-clockwise depending on the direction of the motor.

One end of the drive cable is attached to the cable drum. The cable is routed down around the deflector sheaves at the base of the valve and back up to the cable drum where the other end is terminated forming a closed loop. The drive cable is also attached to a horizontal lift bar which itself is attached across the lower end of the tube.

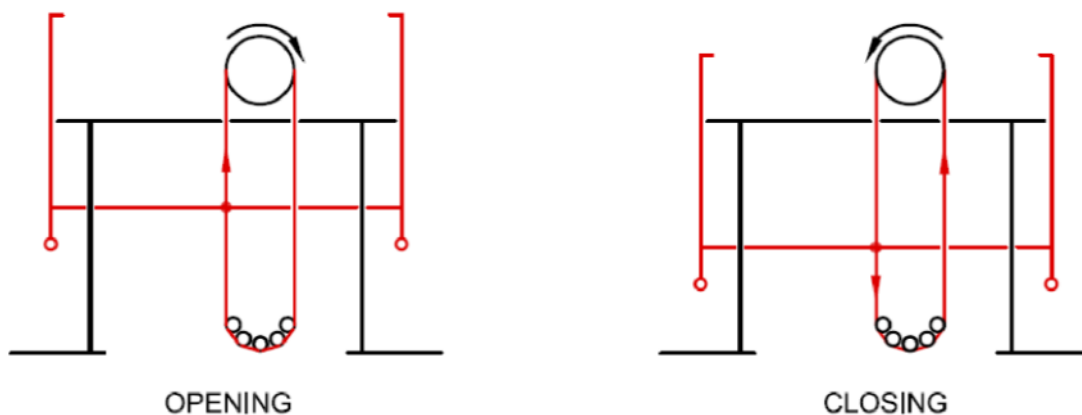

When the motor and cable drum is rotated clockwise, the drive cable pulls up on the lift bar, opening the valve. When the motor and cable drum is rotated counter-clockwise, the other end of the drive cable pulls down on the lift bar via the deflector sheaves, closing the valve. It is normal for there to be slackness on the non-tension side of the cable.

Section 1: Introduction

Operation of the valve motor is regulated by a controller located in a waterproof enclosure on the top of the valve assembly. The controller receives power and a control signal from the aircraft via a three conductor cable. The control signal is provided in the aircraft via a momentary push button and relay.

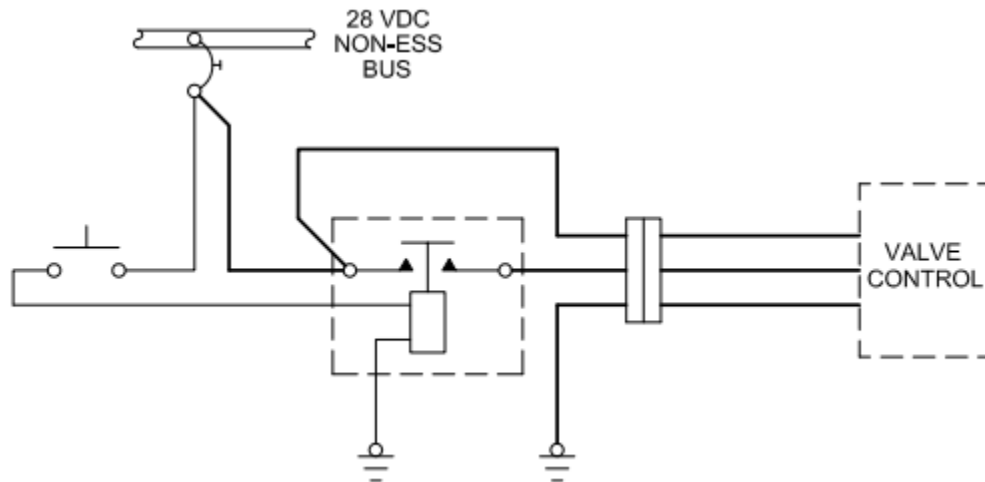

Valve position feedback to the controller is provided by a sensor cam and two sensors. The sensor cam is located on the front of the cable drum and rotates with the motor and cable drum. The sensors are located in the controller enclosure. As the sensor cam rotates, a cut-out in its face actuates the sensors, signalling to the valve controller if the valve is closed, open, or somewhere in between. The sensors are a proximity type and are not affected by any non-metallic contamination of the water.

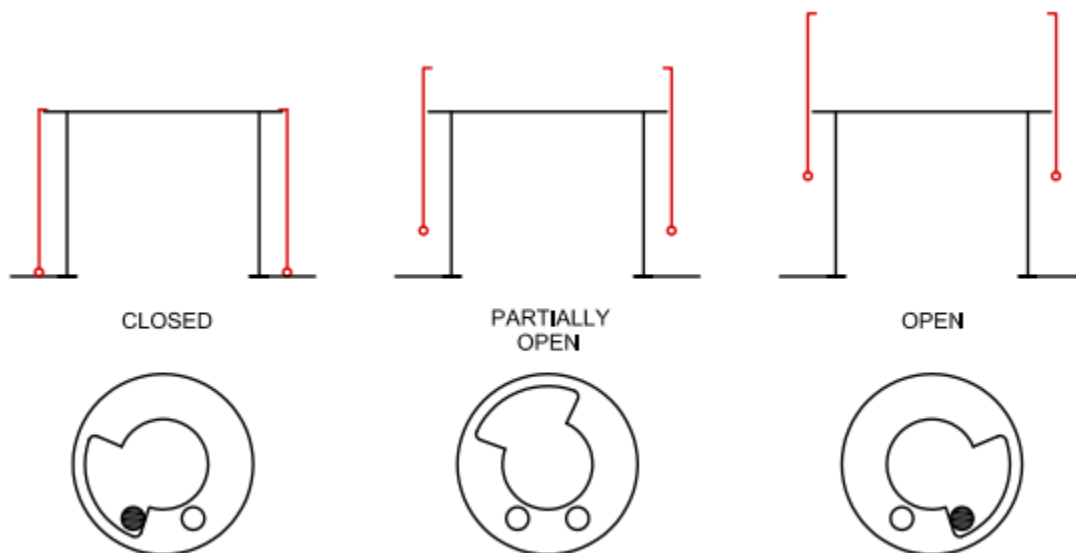







When the controller receives the open signal from the aircraft, the valve motor rotates clockwise and opens the valve. When the open sensor is triggered by the cam, the motor turns off and the valve remains in the open position as long as the open signal is present.

When the operator releases the push button, the open signal is removed. The motor rotates counter-clockwise and closes the valve. When the closed sensor is triggered by the cam, the motor turns off and the tube remains in the closed position.

Section 1: Introduction

The sensor cam can be rotated on the drum to adjust the valve position. Rotating the cam clockwise will lower the valve; counter-clockwise will raise the valve.

There is a status indicator lamp on the side of the control enclosure which indicates the location of the valve tube.

Indicator		Status
	Off	No Power
	Blue	Valve Closed
	Flashing Green	Valve Partially Open
	Green	Valve Open
	Red	Motor Protection Activated
	Flashing Red	Sensor Fault

The controller has a motor protection system to prevent the motor from being overloaded. The motor protection will activate if the valve does not reach its fully open or fully closed position within a given time period, or if the valve is severely out of adjustment.

When activated, the motor protection system isolates the motor from the power source but does not remove power from the rest of the controller. The controller and valve will remain locked in its current state when the motor protection was activated.

The valve will remain operational when the motor protection is activated. For example, if the valve is unable to reach its fully closed position, the motor protection will activate, but the valve can still be opened by triggering the dump switch. Alternatively, if the valve cannot reach its fully open position, the motor protection will activate, but the valve can still be closed by releasing the dump switch.

NOTICE

The information in this manual may only be applicable to products received after the most recent release date of this manual.

CAUTION

The control enclosure is hermetically sealed. Unauthorized opening will void the warranty.

Section 2: Deploying the Bucket

Section 2: Deploying the Bucket

Attaching to the Cargo Hook

Correct attachment of the head is indicated when the ballast on the bucket faces forward in flight which will avoid twisting of the suspension lines. If using a swivel hook, it is recommended to operate in the locked position to assure that the ballast is always facing forward in flight.

CAUTION

The Bambi MAX Bucket may not be suitable for a direct hook-up to the cargo hook. The actual hook-up will be different for various aircraft and operators must comply with all instructions and bulletins supplied by the aircraft manufacturer. It is the operator's responsibility to ensure that the Bambi MAX is correctly fitted to the helicopter.

The Bambi MAX Bucket is rigged for a longitudinal cargo hook. The top shackle on the head acts as the secondary ring for the cargo hook. The operator must supply a primary ring in accordance with the cargo hook manufacturer's recommendations.

If the helicopter has a lateral cargo hook, an additional ring or shackle will be required between the top shackle and the primary ring to rotate the bucket 90°.



WARNING

Ensure that any additional rings and shackles are rated with a minimum safety factor of five for the gross weight of the bucket as shown on the data plate.

Section 2: Deploying the Bucket

Connecting Power

The minimum power requirement to control the Bambi MAX valve is 24-28 VDC, supplying 5 amps, measured at the head of the bucket. The Bambi MAX comes with a three-conductor, 16-gauge control cable that comes from the valve to 3' above the head. Attached to the end of the cable is a male waterproof NEMA5-15P electrical plug (the female receptacle for the helicopter is attached). If an additional new plug is required, an IP67 or better must be used.

CAUTION

Changing the supplied plug and/or receptacle to a non-waterproof (non-IP67) alternative will compromise the hermetic seal of the IVC and actuator enclosures. This may lead to water ingress and failure. Changing the connector(s) may void the warranty.

The purpose of this type of plug is to offer a clean breakaway if the Bambi MAX Bucket must be jettisoned from the aircraft in an emergency. It is suggested that the plug be lightly taped together with vinyl tape, while in use, to ensure that wind action does not separate the plug during flight.

There are three types of suggested wiring installations (see *Section 10: Drawings*):

1. **Pilot control:** In this configuration, the control is wired into the pilot's control column through a relay.
2. **Pilot control (US interagency):** In this configuration, the control is wired into the pilot's control column through a 50 ampere relay as per US interagency regulations. This system can also be used to control a heli-torch, etc.
3. **Crew control (remote power supply):** This configuration allows a crew member or a pilot to control the dumping of the bucket using a battery pack to supply the power to the remote switch. This also eliminates the cost of pre-wiring the aircraft.

Confirm the aircraft has been wired correctly by using the supplied test plug and following the procedure detailed in *Section 6: Troubleshooting and Maintenance* for checking aircraft wiring.

Below is a table which shows the power requirements for the Bambi MAX valve and PowerFill system (optional) by bucket model.

Model*	Current @ 24.5 VDC	
	Valve	PowerFill
BBX1518*	5 A	N/A
BBX1821*	5 A	N/A
BBX2024*	5 A	45 A
BBX2226*	5 A	45 A
BBX2732*	5 A	45 A
BBX3542	5 A	45 A

*Applicable to models of the same size denoted with suffix 'S' or 'L', e.g. BBX1518S.

Section 2: Deploying the Bucket

Longlines

NOTICE

If using a longline, the minimum recommended length is 50 ft (15 m).

When using a longline, care must be taken in selecting the correct gauge of control cable. See the chart below for recommendations.

Wire Length		Wire Type	Connectors	
Feet	Meters		Top	Bottom
0–100	0–30	14/3 SOW	NEMA 5-15P	NEMA 5-15R
100–200	30–61	12/3 SOW	NEMA 5-15P	NEMA 5-15R

When purchasing a synthetic rope longline, it is recommended that the customer also purchase a protective cover and have the conduit inserted at the time of manufacture. However, if this is not feasible due to different conduits for different applications, it is recommended to tape the conduit using duct tape (grey) at 3-4 ft intervals along the longline and cover.

It is not recommended to use zip ties to attach wiring/conduit as this tends to damage the cover and longline. When attaching conduit, allowances must be made for any stretch in the load bearing line and this must be taken into account when attaching to ensure that the terminations are not released from the belly, bucket or hook, etc.

It is also imperative to take extreme care when removing the conduit from the longline, especially if a knife is used to remove the tape as one could inadvertently cut through the cover and damage the synthetic rope. It is important to remember that when conduit is duct taped to the outside of a longline, the flight characteristics can change. In our experience, it may take some time and a few trial flights to determine the length between attachment points of the conduit to the longline.

Section 2: Deploying the Bucket

Checking Tail Rotor Clearance

WARNING

Using a Bambi MAX Bucket with insufficient tail rotor clearance could result in a tail rotor strike which could result in serious injury or death.

When a Bambi MAX Bucket is attached directly to the helicopter cargo hook or attached using a longline less than 50 ft (15 m) in length, it is important to confirm that there is adequate tail rotor clearance. Before using the Bambi MAX Bucket, check the tail rotor clearance.

1. Determine the tail rotor length by measuring the distance from the cargo hook to the closest point on the helicopter tail rotor.
2. Determine the bucket overall length from the following chart:

Model	Overall Length	
BBX1518	13'-3"	4.05 m
BBX1518S	11'-9"	3.58 m
BBX1821	13'-6"	4.10 m
BBX1821S	11'-11"	3.64 m
BBX2024	17'-8"	5.39 m
BBX2024S	13'-5"	4.09 m
BBX2226	13'-6"	4.11 m
BBX2226L	17'-9"	5.41 m
BBX2732	20'-7"	6.27 m
BBX2732S	12'-9"	3.90 m
BBX3137	20'-11"	6.38 m
BBX3542	21'-3"	6.48 m

Lengths are accurate to within 1%. Specifications subject to change.

To confirm the bucket overall length, stretch out the bucket on the ground, pulling the suspension cables taut. Measure the distance from the shackle on the head to the bottom of the shell.

3. The tail rotor clearance is equal to the tail rotor length minus the bucket overall length.
4. **The tail rotor clearance must be a minimum of 6" (0.15 m).**

If the tail rotor clearance is insufficient, shorter suspension lines and deployment lines must be used and can be ordered from SEI. Please specify the model and serial number when ordering parts.

Section 2: Deploying the Bucket

Instant Deployment System (IDS)

The instant deployment system uses a hub and spoke mechanism to automatically expand the mouth of the bucket as soon as the weight of the Bambi MAX Bucket is taken up by the suspension cables.

When the bucket is full, the IDS deployment cable and hub restrainer cables should be slack as they should not bear any load. Their function is to position the hub and spoke mechanism to hold the bucket open.



To deploy the IDS on the ground, reach into the bucket, grasp the hub of the IDS and pull outward fully until the two restraining cables from the hub to the lower bucket shell are tight.

The IDS restraining cables are set at the factory and normally should not require any adjustment.



THIS PAGE INTENTIONALLY LEFT BLANK

Section 3: Accessories

Accessories are optional. Not included with the bucket.

PowerFill Snorkel

PowerFill Snorkel is a system which allows partial or complete bucket fills from a range of previously inaccessible water sources as shallow as 18” (0.46 m). This includes streams, ponds, and low profile dip tanks. It is available for bucket models 1821 to 3542. A separate service manual is available for this product.

The PowerFill Snorkel is an externally mounted pump consisting of a flange assembly and a pump assembly. The flange assembly is permanently installed into the bucket and includes a flapper check valve to prevent water from flowing back through the pump when the pump is not running. Flanges can be installed on several buckets to accept the same pump unit.

The pump assembly is connected to the flange assembly with a camlock fitting which allows the pump to be quickly removed for ease of transport.



The PowerFill snorkel has an electrically driven pump with an optimum output of 425 USG/min (27 L/s). The pump requires a 28 VDC power source capable of supplying 45 A. This supply must be from the aircraft non-essential bus. The installation shall be done in accordance with FAA Advisory Circulars AC43.13-1B and AC43.13-2A and any applicable aircraft manufacturer's instructions. Refer to the Appendix of this manual for a wiring diagram.

WARNING

Do not connect the PowerFill Snorkel system to any aircraft bus bar that is used for emergency or essential loads. Before installation, do an electrical load analysis to ensure that the generator capacity is adequate to operate the system and amend the aircraft electrical load to the new requirements.

Power is transmitted through a waterproof cable to the pump motor. At the top end of the cable, a quick disconnect plug will separate with minimal force in the event of a load jettison. See the following chart for recommended longline wire sizes for the PowerFill Snorkel.

Wire Length		Wire Type	Connectors	
Feet	Meters		Top	Bottom
0–100	0–30	2 x #6 TEW	APP 6326G6	APP 6326G6
101–200	30–61	2 x #4 WELDING	APP 6326G6	APP 6326G6

The pump motor, impeller, and housings are contained within a circular steel filter basket. The filter basket serves to protect the components from impact damage while also acting as a debris screen.

Section 3: Accessories

The pump is fully waterproof in operation to a depth of 10 ft (3.0 m) and can run “dry” without damage. It has a standard hydraulic grease nipple provision to extend the life of the motor output shaft seal.

Foam Injection Systems

Sacksafoam is a foam injection system that uses a pump to dispense a controlled amount of foam concentrate from a reservoir into the water in the bucket. The operation of the Sacksafoam is controlled by the pilot through a control unit, which is mounted in the cockpit. There are two models of Sacksafoam available depending on the location of the foam concentrate reservoir.

Sacksafoam Bladder

The Sacksafoam Bladder uses a collapsible reservoir located in the bucket. An internal check valve stops water from flowing into the bladder and ensures that foam is dispensed only while the injection pump is operating. Because the foam in the bladder displaces the water in the bucket, the total gross weight is always constant.

The Sacksafoam Bladder interfaces with the Sacksafoam controller. Dispensing can be controlled directly from the controller screen or a remote switch.



Bucket Model*	Sacksafoam Part #	Reservoir Capacity			Gross Weight		Power
		Imp Gal	USG	Liters	lb	kg	
BBX1518*	004338	10	12	45	71	32	5 A @ 28 VDC
BBX1821*							
BBX2024*	004339	25	30	114	148	66	
BBX2226*							
BBX2732*							
BBX3137							
BBX3542							

*Applicable to models of the same size denoted with suffix ‘S’, e.g., BBX1518S.

See the following chart for recommended longline wire sizes for the Sacksafoam Bladder.

Wire Length		Wire Type	Connectors	
Feet	Meters		Top	Bottom
0–100	0–30	14/2 SOW	NEMA 1-15P	NEMA 1-15R
100–200	30–61	12/2 SOW	NEMA 1-15P	NEMA 1-15R

Section 3: Accessories

Sacksafoam Heli-Case

The Sacksafoam Heli-Case is a self-contained unit that can be stowed onboard the helicopter. The foam concentrate is stored in a 20 USG tank inside a large plastic case with provision for an extra 5 USG container. The case is designed to prevent foam from contacting the helicopter.

The Sacksafoam Heli-Case interfaces with the Sacksafoam controller which can be mounted directly in the control panel or externally by using the supplied blanking plate and harnesses. Dispensing can be controlled directly from the Sacksafoam controller screen or using the remote control grip.



The Sacksafoam Heli-Case can also interface with the Bambi MAX Bucket, allowing the bucket to be actuated using the trigger on the remote control grip.

Bucket Model*	Sacksafoam Part #	Reservoir Capacity			Gross Weight		Power
		Imp Gal	USG	Liters	lb	kg	
BBX1518*	012743	19	23	87	267	122	15 A @ 28 VDC
BBX1821*							
BBX2024*							
BBX2226*							
BBX2732*							
BBX3542							

**Applicable to models of the same size denoted with suffix 'S' or 'L', e.g. BBX1518S.*

Foam Compatibility

The Bambi MAX Bucket is designed to be effective with foam. All materials used in the manufacture of the Bambi MAX are resistant to the chemical action of foam.

NOTICE

After using foam or retardant in the bucket, it should be washed with fresh water to remove all residue. Foam and retardant can accelerate corrosion and degradation of materials if not removed.

Section 3: Accessories

Power Pack

The Bambi Power Pack is a 28.8VDC, rechargeable power supply that allows the Bambi Bucket or Bambi MAX to be operated independently of the aircraft power.

The plastic case contains a NiMH battery pack and battery charger. The charger operates on either a 120V/60Hz or 240V/50Hz mains power supply. Two power cords are included. One has a NEMA 1-5P plug and the other has a CEE7/16 Europlug.

The Power Pack also includes a dump switch harness to operate the bucket valve, a bucket wiring harness to connect to the bucket, and a grounding harness to ground the system to the airframe to eliminate static charge buildup. All of the wiring harnesses and power cords are stowed inside of the case.

A manually operated circuit breaker located on the front of the case can be used to disconnect the battery power from the bucket harness.



Bucket Model*	Power Pack Part #	Specifications			Gross Weight	
		Type	Output	Capacity	lb	kg
BBX1518*	015989	NiMH	28.8 VDC	3 AH	16	7
BBX1821*						
BBX2024*						
BBX2226*						
BBX2732*						
BBX3137						
BBX3542						

*Applicable to models of the same size denoted with suffix 'S' or 'L', e.g. BBX1518S.

Section 4: Making Adjustments

Adjusting Components

Valve Adjustment

The valve tube has seals located on the top and bottom of the tube. The vertical position of the tube when in the closed position determines the amount of valve sealing. The valve is adjusted at the factory to its correct position and should not require field adjustment under normal conditions.

Following major valve maintenance such as seal replacement or drive cable replacement, the valve adjustment should be checked. If the valve is adjusted too high, it will leak. If the valve is adjusted too low, the motor protection circuit may be activated.

Determine the current state of valve adjustment as follows:

1. Power up the bucket circuit to allow the valve to move to the closed position.
 - If the indicator lamp flashes green or the cable drum / sensor cam oscillates when the valve is closed, then the valve is adjusted too low.
2. Actuate the bucket dump switch and hold to keep the valve in the open position.
 - If the indicator lamp flashes green or the cable drum / sensor cam oscillates when the valve is open, then the valve is adjusted too high.

The adjustment procedure is as follows:

1. Power up the bucket circuit to allow the valve to close.
2. Remove power from the bucket circuit.
3. With the valve in the closed position, locate the set screw on the top of the sensor cam which locks the cam to the cable drum. It should be at approximately the 12 o'clock position.
4. Notice particularly the location of the 9 o'clock hole with respect to the cable anchor block. It is helpful to draw a reference line on the sensor cam to a reference point on the anchor block.
5. Loosen the set screw on the sensor cam using a 3/32" hex key.
6. If the valve is too low, adjust the valve upwards by rotating the sensor cam counter-clockwise so that your reference line moves approximately 1/16" (1.6 mm). Tighten the set screw.
7. If the valve is too high, adjust the valve downwards by rotating the sensor cam clockwise so that your reference line moves approximately 1/16" (1.6 mm). Tighten the set screw.



Section 4: Making Adjustments

8. After adjustment, power up the bucket circuit.
 - The valve should move to the closed position.
 - The indicator light should have a steady blue colour.
 - The cable drum / sensor cam should not oscillate.
9. Actuate the bucket dump switch and hold.
 - The valve should move to the open position.
 - The indicator light should have a steady green colour.
 - The cable drum / sensor cam should not oscillate.
10. Release the dump switch to allow the valve to close.
11. Re-adjust the valve as necessary until the correct open and close conditions are met.
12. Check to see if set screw is tight.
13. Note the position of the reference line or draw a new line at the correctly adjusted position.

Section 5: Packing and Storage

Packing

NOTICE

Always leave the valve open one to two inches as this prevents the bottom seal from collapsing during long periods of storage, leading to longer seal life.

1. Open the valve 1 inch.



2. Collapse the IDS by pushing the hub into the bucket.



3. Grab the control head and pull the suspension lines taut. Tape the lines together in two bunches.



Section 5: Packing and Storage

4. Insert the operations manual into the storage bag.



5. Gather the suspension lines into a coil and stow inside the bucket.



6. Place the head on top of the collapsed bucket.



7. Roll the bucket into a bundle and wrap with straps supplied.



Section 5: Packing and Storage

8. Rotate the shell until the head is under the shell.



9. Take the carrying bag and drape it over the bucket.



10. Roll the bucket over and insert the manual.



11. Close with zipper and store with label showing.



Section 5: Packing and Storage

Storage

Prior to storage, wash the bucket with fresh water and dry completely to prevent the growth of mildew and the corrosion of aluminium and steel parts. If the bucket is used in saltwater, or with firefighting foam or retardant, take extra care when cleaning to remove all contaminants. Salt, foam, and retardant can accelerate corrosion and degradation of materials if not removed. If necessary, a mild detergent can be applied to remove stubborn build-up. Store the bucket indoors and out of direct sunlight.

The Bambi MAX Bucket carrying bag makes a suitable shipping container when shipping via airfreight. Because of the compactness of the Bambi MAX, many operators carry it aboard the helicopter at all times during the fire season. This allows for rapid deployment when required.

Section 6: Troubleshooting and Maintenance

Troubleshooting

Valve Troubleshooting

Problem	Status Lamp	Possible Cause	Solution
No power	○ Off	Circuit breaker tripped	Reset circuit breaker.
		Aircraft / longline wiring	Check aircraft / longline wiring.
Valve Closed Won't Open	● Blue	No open signal	Check aircraft / longline wiring.
	● Green	Controller failure	Contact service centre.
	☀ Flashing Red	Damaged drive cable	Replace drive cable.
Valve Open Won't close	● Green	Sensor(s) out of adjustment	See page 23.
		Aircraft / longline wiring	Check bucket plug. Check aircraft / longline wiring.
	● Blue	Controller failure	Contact service centre.
	☀ Flashing Red	Damaged drive cable	Replace drive cable.
Valve Leaks	● Blue	Sensor(s) out of adjustment	See page 23.
		Damaged seals	Replace seals.
	● Red	Valve adjusted too high	Adjust valve down.
Long Dump Time	● Red	Mechanical Jam	Clear jam / check linkage.
		Valve adjusted too low	Adjust valve up.

Section 6: Troubleshooting and Maintenance

Checking Aircraft / Longline Wiring

The aircraft and longline wiring may be checked using the supplied test plug. Use the following test procedure:

1. Install the test plug into the receptacle of the helicopter wiring harness.
 2. Power up the bucket circuit.
 - The left LED should be extinguished.
 - The right LED should be illuminated amber.



3. Actuate the bucket dump switch.
 - The left LED should be illuminated green.
 - The right LED should be illuminated amber.



Any other LED combination indicates that the aircraft is not wired correctly. See *Section 10: Drawings* for the appropriate wiring schematic.

If a longline is being used, re-connect the longline into the aircraft wiring harness and repeat the above procedure for the receptacle on the bottom of the longline.

Section 6: Troubleshooting and Maintenance

IVC Sensor Adjustment

If the Bambi MAX valve is inoperable with a flashing red light on the indicator, follow this adjustment procedure to reposition the IVC sensors:

1. Loosen the two bolts holding the IVC to the top plate. Do not fully remove the bolts.

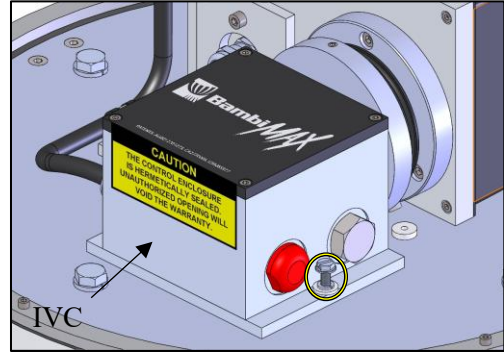

2. Move the IVC away from the cam.

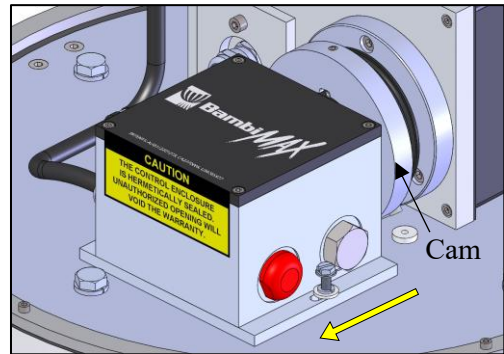

3. Place a 0.030" feeler gauge between the IVC sensors and cam.

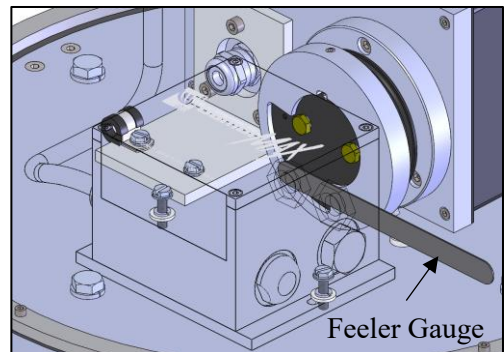

Section 6: Troubleshooting and Maintenance

4. Move the IVC towards the cam, holding the feeler gauge in place.

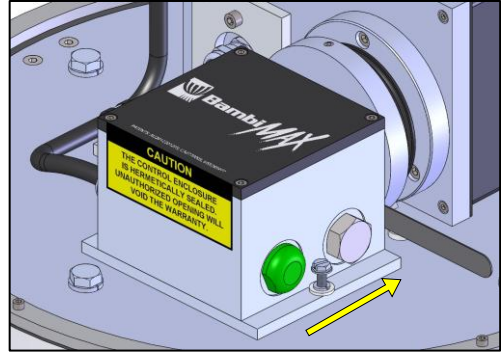

5. Tighten the two loosened bolts in step 1 to secure the IVC.

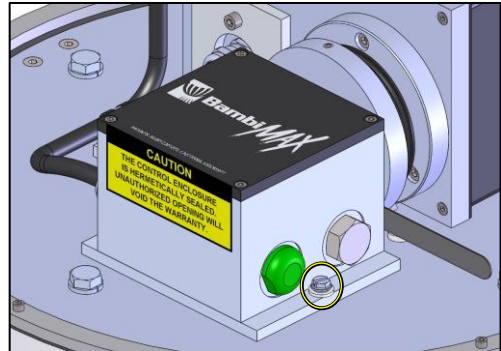

6. Remove the feeler gauge.

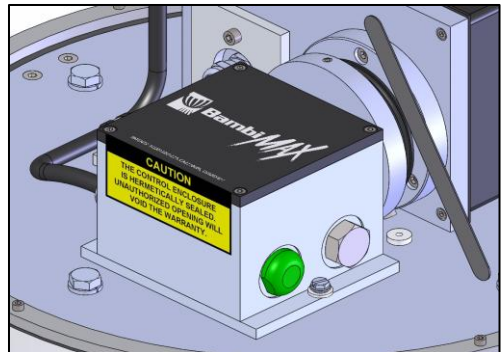

NOTICE

If the indicator light continues to flash red after the adjustment procedure, contact Service Centre.

Section 6: Troubleshooting and Maintenance

Maintenance Procedures

In addition to the daily pre-flight inspections as outlined in the operations manual, follow the weekly inspection procedure for times when the bucket is in continuous use.

Bambi MAX Bucket Weekly Inspection Checklist

1. Check all parts of the system for visible damage or defects.
2. Check for excessive movement in the valve linkage. If excessive side movement develops in the linkage, the bolts (with arrows) must be tightened. Do not overtighten these bolts as they must be turned with only a small amount of force. Once tightened, try to move the linkage from side to side. There should be no movement.
3. Check top and bottom valve seals.

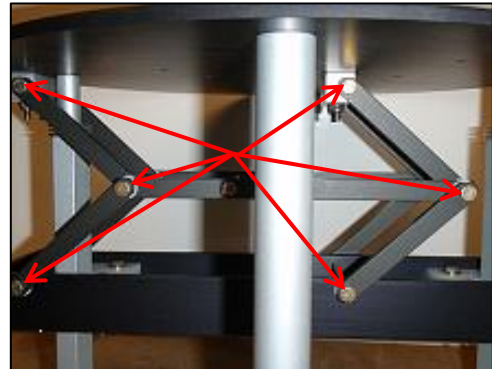

THIS PAGE INTENTIONALLY LEFT BLANK

Section 7: Repair Assessment Guide

Overview of Repair Categories

This section is intended to provide the user with information that will allow for the quick repair assessment evaluation of the Bambi MAX Bucket. The repair assessment process is almost identical for all sizes of the Bambi MAX Buckets, with some exceptions for minor bucket design variations between the models. This section also offers specific guidelines that sort the component defects into one of three categories: Safety, Operational, and Monitor. Use the guideline definitions to determine how urgently a repair should be carried out.

Category 1: Safety

All defects in this category must be repaired immediately before further operation of the Bambi MAX Bucket occurs. Ignoring defects in this category could result in personal injury or damage to equipment. These defects can compromise the following functions of the Bambi MAX Bucket: structural integrity, flight stability, water release, and flight safety.

Category 2: Operational

All defects in this category should be repaired before the next operational day or approximately eight hours of flight time. The defects do not compromise the safety of the bucket but may lead to Category 1 defects, if not addressed within a short time frame.

Category 3: Monitor

Many defects such as wear, abrasion, and minor impact damage do not need urgent attention. Defects of this nature should be monitored daily and repaired before they progress to a Category 2 defect.

NOTICE

It is impossible to provide a recommended service time frame as some buckets are used often while others are used only rarely. In addition, buckets are shifted between operators, making it difficult to track usage. If you are unsure of your bucket's status, check with any Bambi Bucket Service Centre, in your area, for more information and assistance.

Section 7: Repair Assessment Guide

Head Repair Criteria

Category 1: Safety

Cease operations and repair immediately.

- Any visible crack or break on the head.
- Visibly bent shackles.
- Broken or missing safety wire on shackle pins.
- Broken or exposed electrical conductors.
- Broken or missing break-away plug.

Section 7: Repair Assessment Guide

Cables Repair Criteria

Category 1: Safety

Cease operations and repair immediately.

- One or more broken suspension cables or end fittings.
- Broken deployment cable.

Category 2: Operational

Repair before next day's operation or eight hours flight time.

If three or more individual suspension cables or the deployment cable have the following defects:

- 10 or more randomly distributed broken strands or four adjacent broken strands
- Visible kink(s).
- Separation of the strands due to twisting (known as “bird-caging”).
- Evidence of heat damage.
- Abrasion wear comprising of more than 1/3 of the original diameter of the outside individual strands.
- Any visible reduction in outside diameter due to overload.
- Cracked or broken end fittings (some elongation of cable eyes is acceptable).

Category 3: Monitor

Monitor and/or repair if condition deteriorates.

- Wear, broken strands, kinks, and twisting in cable that do not exceed the limits defined in Category 2 defects.

Section 7: Repair Assessment Guide

M-Straps/Top Chains Repair Criteria

Category 1: Safety

Cease operations and repair immediately.

- Broken top chains.
- Broken or missing shackles.
- Two or more broken M-straps.

Category 2: Operational

Repair before next day's operation or eight hours flight time.

- M-straps with more than 25% of the fabric strands broken.
- Visibly worn top chains.
- Bent, gouged, worn or cracked shackles and shackle pins.

Category 3: Monitor

Monitor and/or repair if condition deteriorates.

- Damage to an M-strap that does not exceed 25% of the fabric.
- Minor wear, impact marks, or corrosion on chains.
- Minor wear, impact marks, or corrosion on shackles.

Section 7: Repair Assessment Guide

IDS Hub Repair Criteria

Category 1: Safety

Cease operations and repair immediately.

- Cracks or breaks across the major section of the IDS hub.
- Two or more broken or cracked spoke brackets.
- Two or more broken or missing spokes, clevis pins, shell brackets.
- Three or more bent spokes (bends in excess of 20 degrees = broken).

Category 2: Operational

Repair before next day's operation or eight hours flight time.

- One broken or cracked spoke bracket on IDS hub.
- One broken or missing spoke.
- One broken or missing clevis pin or shell bracket.
- Up to two bent spokes.

Category 3: Monitor

Monitor and/or repair if condition deteriorates.

- Wear on IDS hub.
- Dents, abrasions, and wear on spokes.
- Clevis pin and shell bracket wear.

Section 7: Repair Assessment Guide

Bucket Shell Repair Criteria

Category 1: Safety

Cease operations and repair immediately.

- One or more broken top loop knots (M-strap attachment point to the shell).
- Gross punctures through shell that cut or severely damage one or more panel strips.
- Separation of fabric welds longer than 3" (76 mm).
- Punctures or cuts through shell longer than 3" (76 mm).
- Two or more broken bottom webbing loops.

Category 2: Operational

Repair before next day's operation or eight hours flight time.

- Top loop knots that are worn or have damage to more than 25% of the fabric.
- Cuts, punctures, or weld separations less than 3" and/or cut through more than 25% of a panel strip.
- Bottom webbing loops with more than 25% damage to fabric strands.
- Broken or missing bottom webbing protective wear strips.
- Five or more broken battens.

Category 3: Monitor

Monitor and/or repair if condition deteriorates.

- Wear, abrasions, and cuts to the bucket shell fabric isolated to one side of the material that do not cut through.
- Wear, abrasions, and cuts to the webbing loops, strips, and top loop knots that involve less than 25% of the fabric strands on any portion of the affected webbing.
- Wear and abrasions to webbing protective strips.
- Up to 4" (102 mm) of peeled weld on panel strip.
- Up to four broken battens.

Section 8: Repairs

Rigging Repairs

Suspension Line Replacement

A suspension line should be replaced whenever it displays noticeable kinking or fraying. Factory replacement lines come pre-swaged with connection links to make replacing quick and easy.

To remove the connecting link between the suspension line and the M-strap, follow these procedures.

1. Locate a metal bar with a 5/16" hole (or drill a 5/16" hole into any metal bar). If you are unable to locate a metal bar, a wooden block will work, however, make sure to drill the hole into the end grain.



2. Place the connecting link with the pin located over the hole and using a 3/16" punch, drive pin through the center holding sleeve.



3. After the pin is free, remove the old suspension line. Place the new line in the connecting link by inserting the pin into one side of the connecting link. Using a hammer, drive the pin in until it is flush with both sides of the connecting link.



Section 8: Repairs

M-Strap Replacement

Replace M-straps if they become noticeably worn. If the M-straps are frayed, they can be repaired by melting the fray with a lighter to stop the fray from spreading. The length of the M-strap is critical to the Bambi MAX Bucket functioning correctly. It is recommended that you replace worn straps with factory-supplied equipment.

There are two types of straps. The short straps are vertical and are a continuous loop. The long straps are diagonal and have a loop on each end.

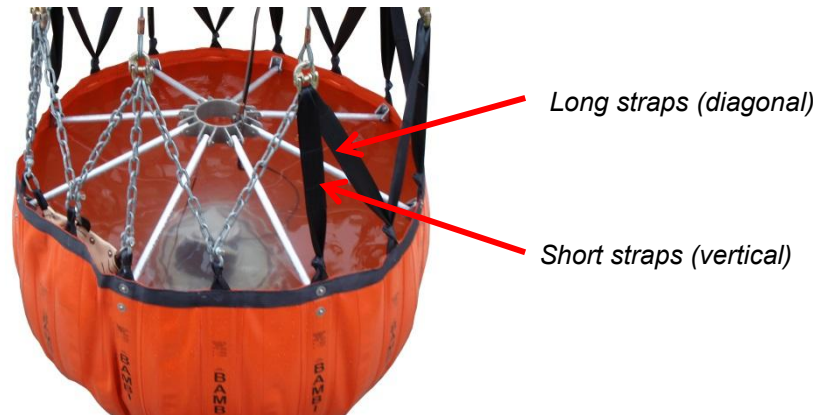

Replace one set of straps at a time to avoid confusion.

1. Cut off the old strap from the shackle.
2. Using needle nose pliers, insert the tip under the top webbing layer.



3. Fully insert the pliers at the far left hand side of the top layer.



Section 8: Repairs

4. Holding the pliers tight, turn your hand clockwise. Repeat the operation until the knot is loose enough to remove the strap.



5. Complete step 'a' or 'b' depending on whether the strap is short or long.
 - a. For short straps, grasp the strap and rotate until the joint is centered.



- b. For long straps, locate the center of the strap and fold back to form a loop.

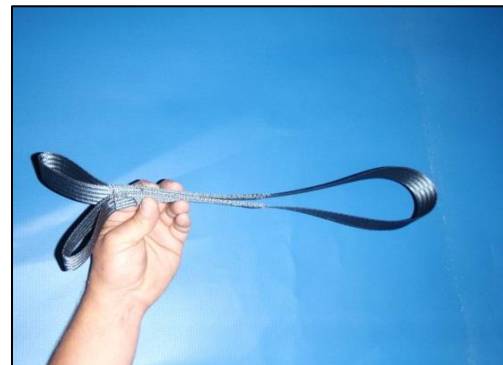

6. Pass the loop of the strap through the loop on the top of the bucket.



Section 8: Repairs

7. Twist the strap loop eye 180 degrees.



8. Rotate the eye to the opposite side.



9. Pull strap end through the eye.



10. Pull strap tight.



Section 8: Repairs

11. The M strap set should now look like this. The suspension line attaches to the top of each M-strap set.



IDS Replacement

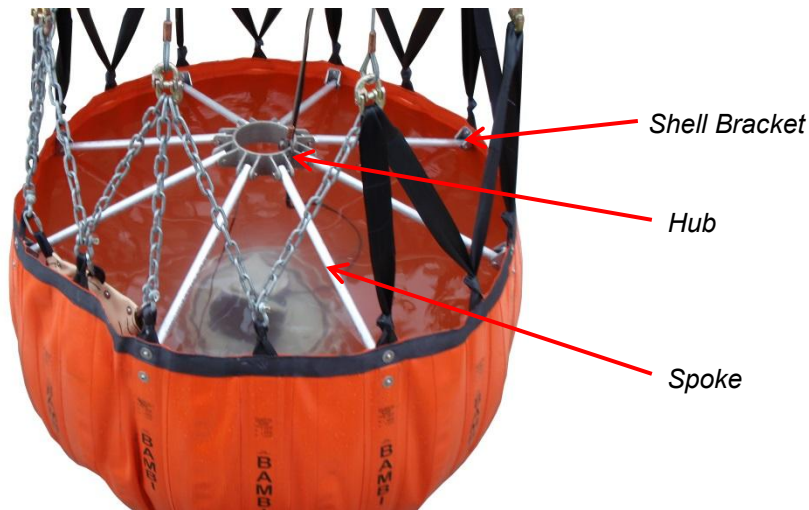

The IDS can be replaced either as a complete kit or as individual pieces, as required. See *Section 9: Specifications and Parts* for detailed parts drawings. Follow the procedure below to replace the entire assembly.

1. Disconnect the valve's electrical harness from the head and pass the cable through the IDS hub.
2. Disconnect the IDS restrainer cables from the cable restrainer brackets in the shell.
3. Disconnect the IDS deployment cable from the head.
4. Remove the pins which secure the outer ends of the spokes to the shell brackets. Remove the IDS assembly from the bucket.
5. Inspect the shell brackets and replace as necessary.
6. With the ballast oriented at the 6 o'clock position, rotate the new IDS assembly so that the deployment cable faces upward at the 3 o'clock position.
7. Attach the two spokes at either side of the 12 o'clock position using the stainless steel clevis pins. Working around the bucket perimeter, attach the rest of the spokes.

Section 8: Repairs

8. Once the IDS is fully installed, test for fit. You should be able to pull the hub past the midpoint position with a slight effort. If the IDS is either too loose or too tight, it will require adjustment. If the IDS is too tight, adjust as follows:
 - a. Cut off one spoke just above the existing hole on one end only. Redrill a new hole centered the same distance from the new end of the spoke as the other spokes. Replace the spoke and check for fit.
 - b. If the IDS is still too tight remove another spoke directly across from the first modified spoke and repeat the previous step.
9. Pass the tripline through the hub and re-attach to the dump valve
10. Attach the IDS deployment cable to the control head small adjustment chain.
11. Attach the IDS restrainer cables.

Bottom Loop Repairs

If the bottom loops, which hold the chain, become worn, the frays can be melted with a lighter to prevent them from spreading. If the bottom loops require replacement, they should receive an overlay of heavy duty wear-resistant webbing.

Section 8: Repairs

Valve Repair and Replacement

Valve Removal

Whenever any valve maintenance, such as seal changes or maintenance on the valve cycling, must be done, it is recommended that you remove the valve from the Bambi MAX shell. To remove the valve, follow the procedure listed below:

1. Make sure that the ballast is on the bottom of the shell before removing the valve. Detach the power cable from the head and IDS deployment cable, coil the cable into an 18" coil and place it inside the top of the shell.
2. Detach one or two spokes from the shell. These spokes should be in the 3 to 5 o'clock location.
3. Remove the four bolts holding the valve to the bottom plate.

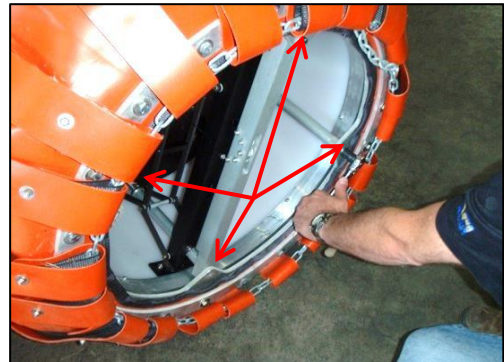

Section 8: Repairs

4. Roll valve out of shell and move to repair area.



Valve Installation

The following procedure will allow one person to easily install the valve.

5. Make sure the ballast is still at the bottom. Roll the valve through the opening. Leaving the control cable at the top of the shell, roll the valve to the base of the shell



1. Place the valve inside the valve-guard, then rotate the valve until the control box is in the position shown in the picture to the right.



Section 8: Repairs

2. Install the four 3/8" bolts on the base of the valve. Some rotation may be necessary to line up the standoffs to the bottom plate holes. When lining up the holes, always move the standoff to the nearest bottom plate hole.



3. String the control cable. Before unrolling the coil of cable, pass it through the center of the IDS hub.

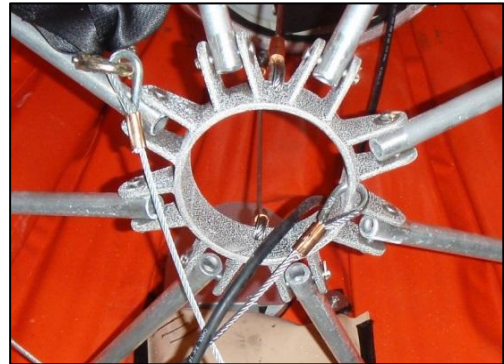

4. Check to ensure that you have at least 6" of slack in the control cable before attaching the cable to the head with the four tie wraps.



Section 8: Repairs

Bottom Seal Replacement

To change the bottom seal, it is recommended that the valve be pulled from the shell although it is not necessary to detach the control cable from the IDS deployment line. Depending on circumstances, the seal can be replaced while the valve is next to the shell, but the valve should be placed on a clean level surface such as a piece of cardboard or plywood.

To remove the valve, please refer to the valve removal section in the maintenance section of this manual. Once the valve has been removed, follow the procedure below.

1. To make the valve more stable, open the valve until the top of the tube is level with the top of the motor and cut the power to keep it in this location.



2. Turn the valve over.

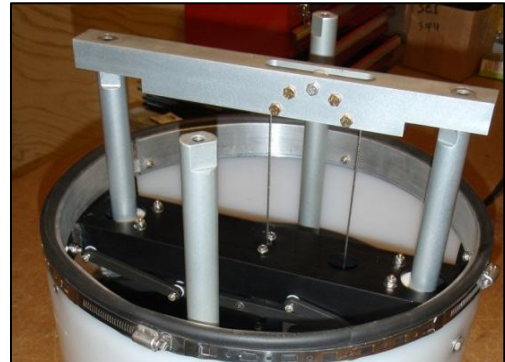

3. Loosen the two tension clamps and lower the clamps into the position shown in this picture.
4. Remove the seal and clean any debris from the bottom of the tube and groove.



Section 8: Repairs

5. Install the replacement seal over the valve tube and move the clamp into position. Make sure that the tensioner clamps are located between the lift bar bolts.
6. Tighten the tensioner clamps. Make sure to tighten each clamp equally as this will eliminate a problem of the clamp releasing as one of the tensioners is not engaged enough to hold the clamp.



When the valve is closed, ensure no light is passing between the bottom seal and base ring. If light is passing through in a specific area, loosen the tensioner clamp and push the seal down in the specific area, then tighten the clamp ring. Repeat until light is no longer visible.

Top Seal Replacement

To change the top seal, the valve does not need to be removed from the shell.

To remove the valve, please refer to the valve removal section in the maintenance section of this manual. Once the valve has been removed, follow the directions below.

Tools required: 1/8" hex key

1. To replace the top seal with the valve still in the bucket, first detach the control cable from the head and the IDS deployment cable and hub. Coil the cable up and place it inside the top of the shell.
2. Remove all the socket head cap screws which secure the top clamp ring and top seal to the valve tube.

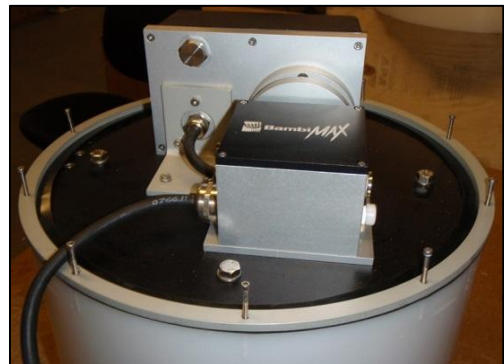

Section 8: Repairs

3. Remove the top ring and pass the coiled control cable through the middle of the ring. Take the ring and old seal out of the shell.
4. Place the ring on a level surface with all bolts inserted into the ring. Slip the new seal over the bolts.



5. Pass the control cable through the ring, making sure to pass the cable through from the seal side.



6. Start all screws into the tube, turning them in about 1/8". This allows you to locate the holes in the tube easier by lifting the ring and seal to see the holes.
7. Tighten all screws equally as they are going into plastic. Torque to 20 in-lb. Do not over tighten as you would in metal.

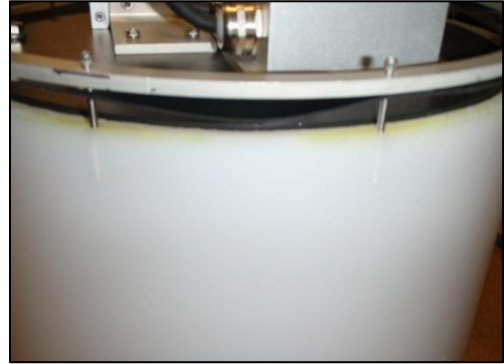

8. String the control line and, before unrolling the coil of cable, pass it through the center of the IDS hub. Once all the cable is outside the bucket with no slack, push it 6" back into the bucket.

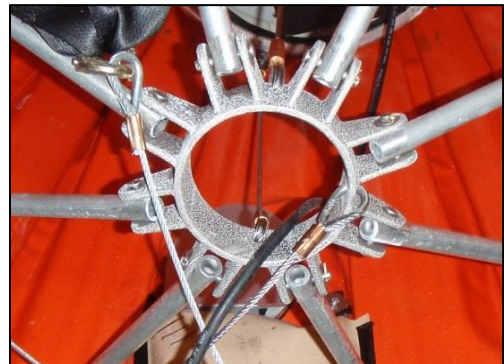

Section 8: Repairs

9. Reattach the control cable to the head as shown in the picture using four tie wraps.



Drive Cable Replacement

If the helicopter is not available as a power and activator source, a 24-28 VDC power source can be used. Connect the negative line to the narrow blade on the plug and the positive to the round pin. The valve will be in the closed position. To open the valve, jumper a wire from the round plug to the wide blade. If the valve doesn't operate, check that the wiring in the plug hasn't been changed. Open the plug and check the green wire which should go to the green screw, black wire to brass screw, and white wire to silver screw.

The drive cable can be replaced with the valve in the bucket but, if you are doing other maintenance work on the valve, it will be easier to change the cable outside the bucket.

1. Cut the cable below the lift bar.
2. Remove the cable retainer from the lift bar.
3. Remove the cable by pulling the unswaged end through the sheave and lift bar.

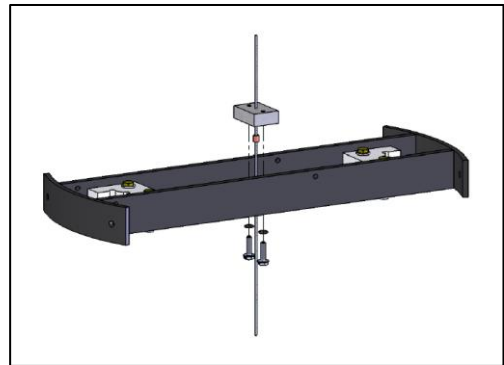

4. To remove the cable ends from the cable anchors, the motor will have to be started and stopped when a cable anchor is close to the top. Loosen the two cable anchor screws and pull the cable through.
5. Activate the motor again to get the second cable anchor to the top. Loosen the two cable anchor screws and pull the cable out.



Section 8: Repairs

NOTICE

Use cyanoacrylate glue on the ends of the new cable, to prevent fraying.

6. Examine the new drive cable to determine the shorter end.
7. Insert the short end of the drive cable into the cable retainer.
8. Insert the long end of the cable through the hole in the lift bar.



9. Secure the cable retainer to the lift bar.

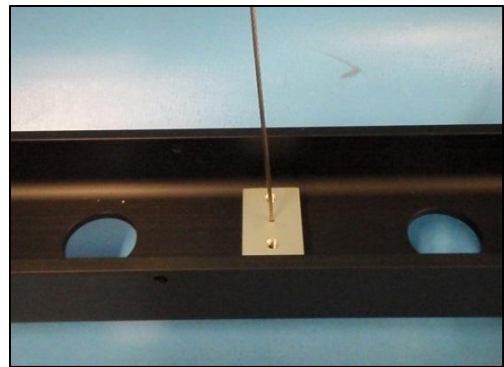

10. Trim the short end of the drive cable and insert the cable through the cable bushing.

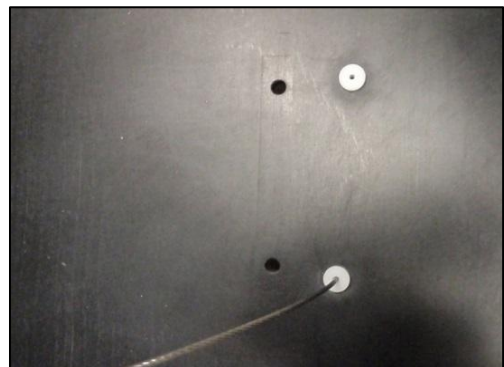

Section 8: Repairs

11. Connect the control cable to a 24-28 volt DC power source, open the valve about a 1/3 of the way and cut the power. The cable anchor should be close to the position shown in this picture. Feed the cable through the cable anchor, pull it snug but do not tighten.



12. Install a 5/16" spacer plate between the sheave bar and lift bar. Place a 5-10 lb weight on the lift bar to hold it down.

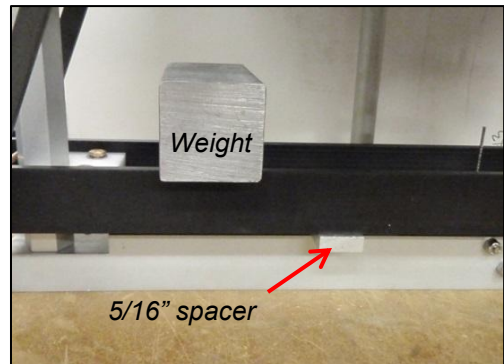

13. Turn on the power. The valve will close. Pull the cable tight and secure with cable anchor screws.

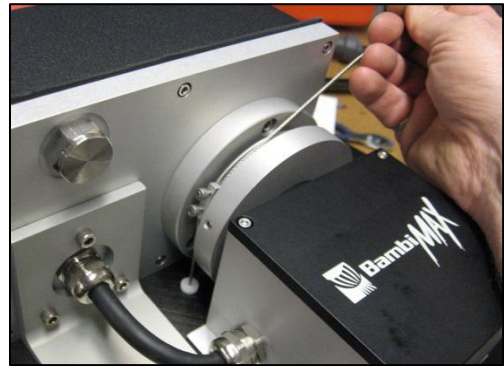

14. Install a piece of 1/8" x 1" heat shrink over the cable next to the anchor. Cut off the excess cable as close to cable anchor as possible.



Section 8: Repairs

15. Remove the weight and spacer from the lift bar, install the cable over the five sheaves and trim the end of the cable.



16. Pass the cable to the inside of the carrier cross bolt, through the cable bushing in the top plate.

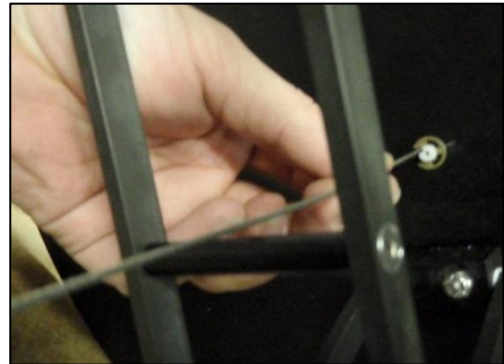

17. Turn on the power and open the valve to its fully open position. Install the cable through the second cable anchor and, then, pull the cable tight and secure with cable anchor screws. Install a piece of 1/8" x 1" heat shrink over the cable next to the anchor. Cut off the excess cable as close to cable anchor as possible.
18. Adjust valve to correct position (see *Section 4: Making Adjustments*)

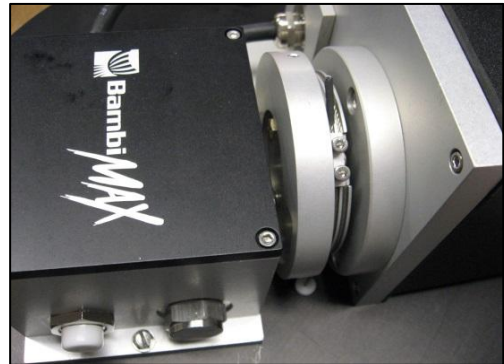

Section 8: Repairs

Guide Bushing Replacement

To change the guide bushings, follow the steps listed below.

1. Open the valve about halfway.
2. Remove the two bolts holding the old bushing in place and remove the old bushing.
3. Place the new bushing into position.
4. Insert the bolts, attach the nuts, and tighten.

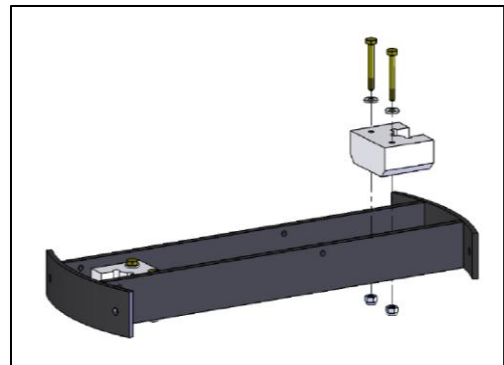

5. Run the valve up and down. If any slowing of the valve movement or jamming is noticed, loosen the bolts on one bushing and pull it away from the guide rod, towards the center of the valve, to allow some clearance between the bushing and guide rod, then re-tighten the bolts.
6. If slowing or jamming still occurs, loosen the guide bushing bolts on the opposite side and repeat the operations of step 5.

Section 8: Repairs

Shell Repairs

CAUTION

Please read these instructions carefully and follow them exactly to obtain a good repair. Failure to follow these instructions or poor repair workmanship can lead to failed repairs and/or more damage to the bucket.

Tools and materials to perform shell repairs can be found in *Section 9: Specifications and Parts*.

Temporary Repairs with Sealing Clamps

Repair clamps are used for an immediate repair to prevent the loss of liquid through large rips or holes. For example, if a vehicle accidentally backed into a bucket and caused a 3" (76 mm) long rip in the bucket, a repair clamp could be inserted to stop the loss of liquid. Repair clamps are only used for temporary repairs. The damage should be permanently repaired with a patch when the bucket can be set aside for 24 hours.

1. Select the largest clamp that will just slip through the hole in the item. The size of cut or hole will determine the size of the sealing clamp to use:
 - For a cut or hole up to 2" (5 cm), use a 3" (7.6 cm) clamp.
 - For a cut or hole up to 4" (10 cm), use a 5" (12.7 cm) clamp.
 - For a cut or hole up to 6" (15 cm), use a 7.5" (19 cm) clamp.
2. Keeping hold of the string, slip one half of the repair clamp through the hole as indicated.



3. Pull the bolt up through the hole. Turn it until the clamp lines up with the hole.

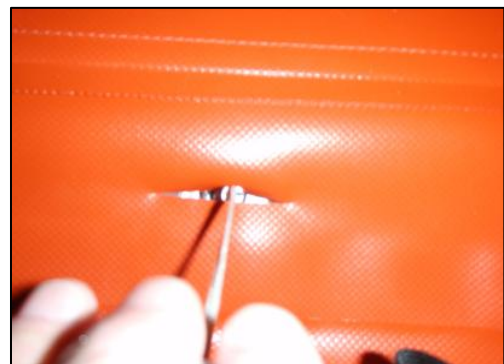

Section 8: Repairs

4. Place the top of the clamp over the bolt.



NOTICE

Leaving the clamp's string on makes it easier to remove the repair clamp when placing a permanent patch on the bucket.

NOTICE

Tightening the nut with tools may break the bolt away from the lower clamp. Overtightening can also deform the clamp and cause leaks.

Temporary Repairs Using Glue

Before commencing repairs using glue, the weather should be warm (above 60 °F or 15 °C) and dry. In conditions of high humidity, a proper technique is essential for securing the bond strength desired. The presence of surface moisture can destroy the effectiveness of the cemented bond.

The evaporation of solvent from the adhesive may reduce surface temperature below the dew point resulting in condensation of water vapour on the surface of the adhesive. This is often visible as fogging or a milky white appearance on the surface. The use of a solvent to clean the surface prior to cementing can also reduce temperatures below the dew point.

To overcome the high humidity problem, raise the temperature of the patch area. This can be accomplished with a warm air fan.

WARNING

Glue vapours are highly explosive! Explosive vapours may occur causing fire and/or injury. Keep away from all sparks, flame, lighters or cigarettes.

Solvent and glue are both extremely hazardous. Use solvent and glue under well ventilated conditions only.

Use an approved respirator mask to avoid breathing fumes.

When using a warm air fan, either use one which is rated EXPLOSION PROOF or make sure that there is a steady flow of air past the work area to remove fumes as they are generated.

Section 8: Repairs

NOTICE

Try a test repair before attempting to repair the bucket. This will verify your technique without risking damage to the bucket. It is much harder to fix a repair once a failed attempt has been made as the hardened glue is difficult to remove.

Damage to the outer fabric coating, or pinholes which are not leaking, can be repaired with glue only. To perform this type of repair, follow these steps:

1. Fill the weight bag with water prior to beginning repairs.
2. Clean the area to be repaired with an abrasive pad dampened with solvent. Remove all traces of masking tape, if previously used. If possible, place a piece of masking tape on the back side of the item being repaired.



3. Paint the damaged area with glue. Use a thick coat of glue, overlapping the edges of the repair by 1" (25 mm). Be sure that the edges are well coated. A damaged coating should be given two coats of glue. Apply the second coat within four hours of the first coat.



Damage to the base fabric must be repaired with a patch. To perform this type of repair, follow these steps:

4. If there is dampness around the area to be patched, dry the area with a hot air fan or heat gun. Any loose coating should be cut back with scissors. Support the damaged area on a flat, solid platform. This platform should be strong enough to support the fabric (flat) and allow the patch to be rolled once it is in place.

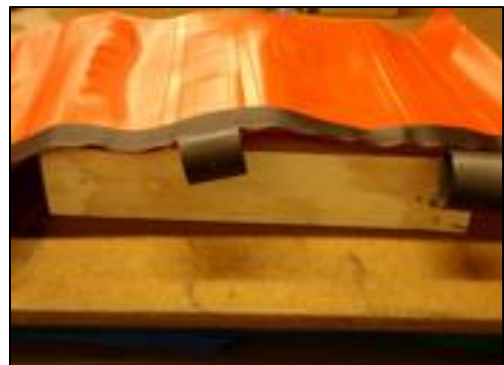

Section 8: Repairs

5. Scrub the damaged area with an abrasive pad dampened with solvent (isopropyl rubbing alcohol is recommended). Scrub vigorously to remove the cured surface. The area should be clean and dry with a dull matte finish.



6. Wipe with a rag, dampened with solvent, to remove any residue from cleaning. Check to see if the area is totally clean and all coated surfaces and edges are dull. If not, repeat the cleaning. This is critical for a good glue bond.

CAUTION

Solvent will damage the fabric if too much is used or if the fabric is left exposed to solvent residue.

7. Cut a patch at least 2" (50 mm) larger in every direction from the damaged area. A round patch is recommended but, if a rectangular patch covers the damage better, then round all corners. Clean the patch by scrubbing with a pad dampened with solvent. Rub vigorously to remove the gloss from the fabric. Clean **both sides of the patch**, as it is easy to get the patch turned over during installation. The colour of the patch will vary depending on the product repair kit.



8. Apply glue to the patch and damaged area. Wait 30 minutes (at 75 °F or 22 °C) for some of the solvent to evaporate from the glue. The glue should become thicker but still be quite wet. If it has been allowed to dry too long, give both sides another thin coat. If the glue has dried too long, it will be difficult to avoid entrapping air bubbles in the bonded joint.

9. Place the center of the patch down first, then roll it out towards the edges with the roller. This expels trapped air. Once the patch is rolled down, do not let it lift up. This will prevent air from getting under the patch which causes a weak bond.



Section 8: Repairs

10. Place a plastic cover sheet over the patch followed by a weight bag for 12 hours at room temperature. Remove the weight bag and leave to dry for 24 hours.

11. If the patch will be subjected to abrasion after 24 hours, paint over the patch with glue. Painting the patch also provides protection from ultraviolet light and weather. Allow the bond to harden for 24 hours at room temperature before using the item.



NOTICE

Allow repair to harden for 24 hours at room temperature before using the item.

Repairs will likely fail if:

- The area to be repaired is not perfectly clean and scrubbed to a matte finish before applying the patch.
- Repairs are attempted during wet or cold weather.
- The glue and patch are not properly placed, creating air bubbles between the glue and the patch.
- The patch is not weighed down for 24 hours.
- The bucket is used before the glue has set.

NOTICE

Aquaseal® urethane adhesive is designed for use on fabrics like the Bambi MAX Bucket shell. The shelf life of this adhesive is about one year. Fresh adhesive can be obtained directly from SEI Industries Ltd.

Section 8: Repairs

Hot Air Gun Patching

Hot air gun patching is the preferred method because it provides the most durable, permanent repair possible.

Tools and materials required:

- Patches
- Plastic hand-held roller
- Hot air gun with wide surface nozzle
- Isopropyl alcohol
- Scissors

WARNING

It is extremely dangerous to use a hot air gun in the presence of flammable fumes such as gasoline or paint thinner. There is a high risk of explosion and/or burns.

CAUTION

Injury, especially to hands and fingers, can occur when using a hot air gun. Most welding will occur at temperatures of 800-1000 °F. Wear gloves to protect skin from overheating, burning and blistering.

The procedure for hot air patching is as follows:

1. In a well-ventilated location, clean the area to be repaired as well as one side of the patch with an abrasive pad. Wipe down the repair area and patch with isopropyl alcohol.
2. Mount a wide surface air nozzle on the hot air gun to direct the heat flow in a large pattern. Turn the power on, adjust the temperature in the low range first and let the hot air gun warm up. Increase the temperature as required during the operation.



CAUTION

Overheating can occur quickly and can damage the product. It's recommended that you test, using the supplied fabric samples, to determine the correct temperature to be used and the duration of heat to be applied.

Section 8: Repairs

3. Starting from the center of the patch (held down by the roller), concentrate the heat flow equally to patch and fabric. Apply a light pressure with the roller when the fabric starts melting. This can be seen as small bubbles.
4. Roll the patch down to fuse it to the fabric, moving roller and gun simultaneously. Repeat on the unfused portion of the patch. Let the repaired area cool down. Attempt to peel off at the edges with your fingers. If there is even a slight peel, repeat the operation locally. Otherwise, the repair is finished.



Section 9: Specifications and Parts

Capacity and Weight Specifications

Capacities and weights are accurate to within 5%. Specifications are subject to change.

CAUTION

The selection of a Bambi MAX Bucket model for a specific aircraft is dependent on many factors including aircraft weight, fuel weight, operation elevation, and atmospheric conditions.

The helicopter operator must select a bucket model which is appropriate for their specific situation.

The operator must also ensure that the bucket selected does not pose a tail rotor strike hazard.

Bambi MAX Bucket

Model	Capacity			Empty Weight		Gross Weight	
	Imp Gal	US Gal	Liters	lb	kg	lb	kg
BBX1518	150	180	680	95	43	1600	720
BBX1518S	150	180	680	95	43	1590	720
BBX1821	180	216	820	105	48	1900	860
BBX1821S	180	216	820	105	47	1900	860
BBX2024	200	240	910	140	63	2140	970
BBX2024S	200	240	910	137	62	2140	970
BBX2226	220	260	1000	138	63	2340	1060
BBX2226L	220	260	1000	140	63	2340	1060
BBX2732	270	320	1230	148	67	2850	1290
BBX2732S	270	320	1230	143	65	2840	1290
BBX3137	310	370	1410	152	69	3250	1470
BBX3542	350	420	1590	155	70	3660	1660

Section 9: Specifications and Parts

Bambi MAX Bucket with PowerFill Snorkel

Model	Capacity			Empty Weight		Gross Weight	
	Imp Gal	US Gal	Liters	lb	kg	lb	kg
BBX1821	180	216	820	155	70	1950	890
BBX1821S	180	216	820	155	70	1950	890
BBX2024	200	240	910	190	86	2190	990
BBX2024S	200	240	910	187	85	2190	990
BBX2226	220	260	1000	188	85	2390	1080
BBX2226L	220	260	1000	190	86	2390	1080
BBX2732	270	320	1230	198	90	2900	1310
BBX2732S	270	320	1230	193	87	2890	1310
BBX3137	310	370	1410	202	92	3300	1500
BBX3542	350	420	1590	205	93	3710	1680

Bolt Torque Specifications

Unless otherwise specified, bolts shall be torqued to the following specification:

#8-32	#10-24	#10-32	1/4-20	5/16-18	3/8-16	1/2-13	1/2-20
17 lb-in 1.9 Nm	25 lb-in 2.8 Nm	28 lb-in 3.2 Nm	4.9 lb-ft 6.7 Nm	10 lb-ft 14 Nm	18 lb-ft 24 Nm	44 lb-ft 59 Nm	49 lb-ft 67 Nm

Section 9: Specifications and Parts

Parts

Head

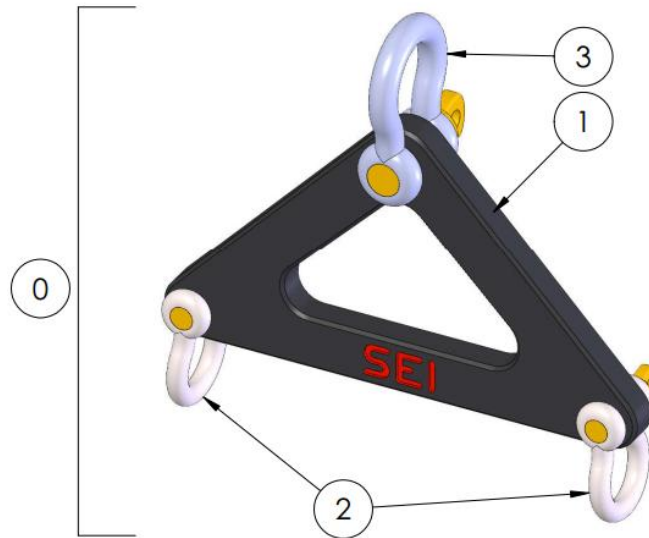

ITEM	MODEL	PART #	DESCRIPTION	QTY
0	ALL	005747	HEAD, ASSY	1
1	ALL	007272	HEAD, SMALL	1
2		001794	SHACKLE, ANCHOR, SCREW, 3/8, GLV	2
3		001795	SHACKLE, ANCHOR, SCREW, 1/2, GLV	1

Section 9: Specifications and Parts

Suspension

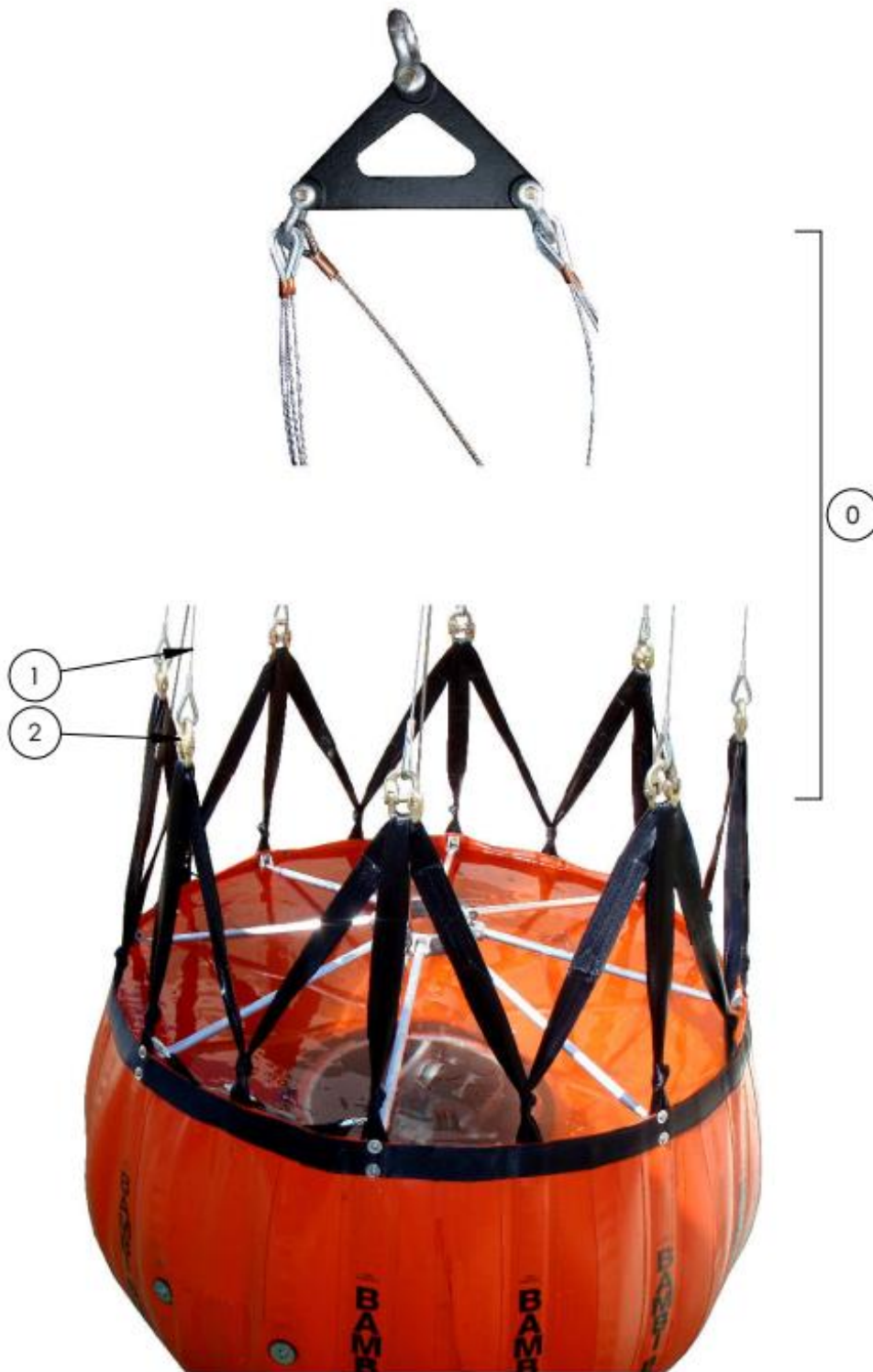

Section 9: Specifications and Parts

Suspension (continued)

ITEM	MODEL	PART#	DESCRIPTION	QTY
0	BBX1518	007677	CABLE, SUSPENSION, SET	1
	BBX1518S	007676		
	BBX1821	007677		
	BBX1821S	007676		
	BBX2024	007678		
	BBX2226L			
	BBX2024S	007679		
	BBX2226			
	BBX2732	007680		
	BBX2732S	008855		
	BBX3137	007680		
	BBX3542			
1	BBX1518	005545	CABLE, SUSPENSION, PAIR	4
	BBX1518S	005544		
	BBX1821	005545		
	BBX1821S	005544		
	BBX2024	005547		
	BBX2226L			
	BBX2024S	005548		
	BBX2226			
	BBX2732	005549		
	BBX2732S	008854		
	BBX3137	005549		
	BBX3542			
2	ALL	004057	LINK, CONNECTOR, SMALL, PLT	8

Section 9: Specifications and Parts

Bucket Shell

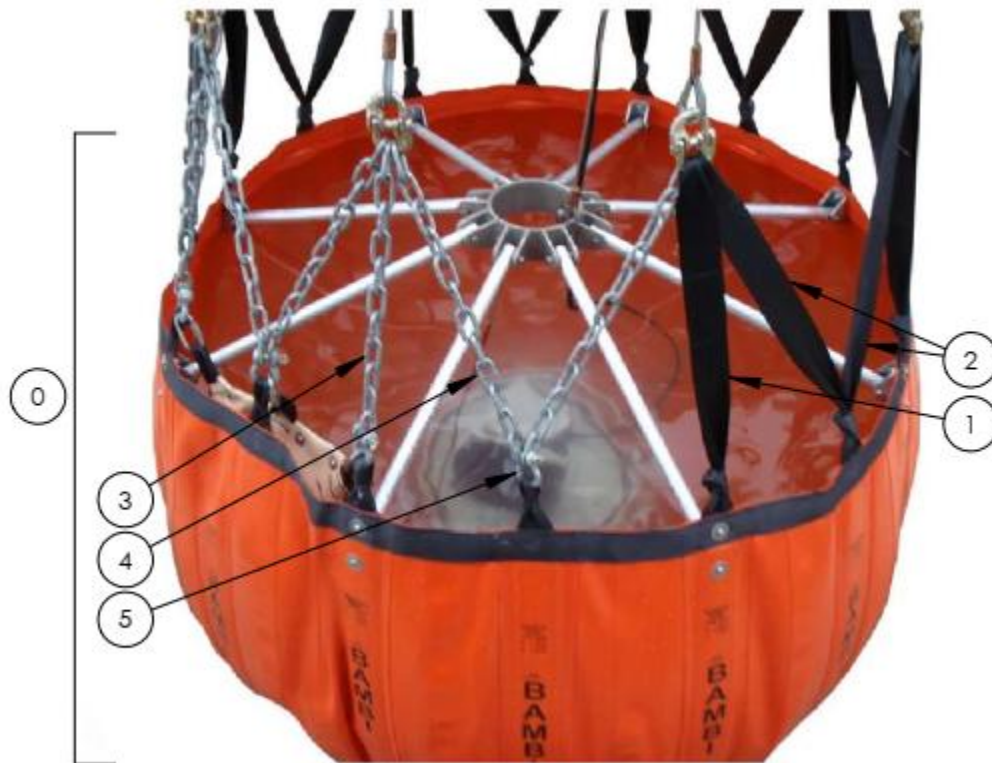

Section 9: Specifications and Parts

Bucket Shell (continued)

ITEM	MODEL	PART #	DESCRIPTION	QTY
0	BBX1518	008681	SHELL, BAMBI, ASSY	1
	BBX1518S			
	BBX1821	008684		
	BBX1821S			
	BBX2024	008685		
	BBX2024S			
	BBX2226	007733		
	BBX2226L			
	BBX2732	008686		
	BBX2732S			
	BBX3137	017063		
	BBX3542	008688		
1	BBX1518	005467	STRAP, M, LOOP	8
	BBX1518S			
	BBX1821			
	BBX1821S			
	BBX2024	005469		
	BBX2024S			
	BBX2226			
	BBX2226L			
	BBX2732	005471		
	BBX2732S			
	BBX3137			
	BBX3542			
2	BBX1518	005468	STRAP, M, STRAIGHT	8
	BBX1518S			
	BBX1821			
	BBX1821S			
	BBX2024	005470		
	BBX2024S			
	BBX2226			
	BBX2226L			
	BBX2732	005472		
	BBX2732S			
	BBX3137			
	BBX3542			

Section 9: Specifications and Parts

Bucket Shell (continued)

ITEM	MODEL	PART #	DESCRIPTION	QTY
3	BBX2024	005524	CHAIN, TOP, 14.5"	2
	BBX2024S			
	BBX2226			
	BBX2226L			
	BBX2732	005526	CHAIN, TOP, 18.5"	
	BBX2732S			
	BBX3137			
	BBX3542			
4	BBX2024	005525	CHAIN, TOP, 16.25"	6
	BBX2024S			
	BBX2226			
	BBX2226L			
	BBX2732	005527	CHAIN, TOP, 21.3"	
	BBX2732S			
	BBX3137			
	BBX3542			
5	BBX2024	013134	SHACKLE, ANCHOR, SCREW, 5/16, SS	5
	BBX2024S			
	BBX2226			
	BBX2226L			
	BBX2732			
	BBX2732S			
	BBX3137			
	BBX3542			

THIS PAGE INTENTIONALLY LEFT BLANK

Section 9: Specifications and Parts

Bucket Shell – Battens, Wear Strips & Bottom Chain

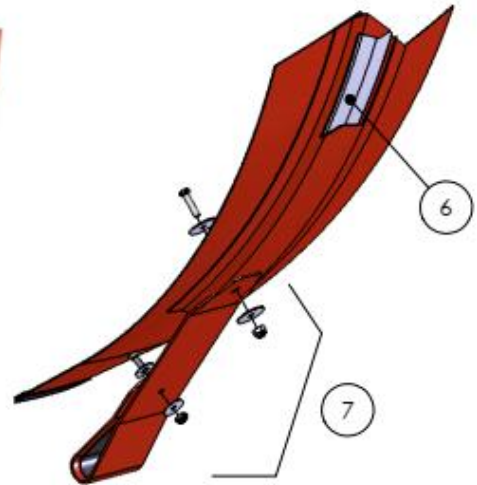
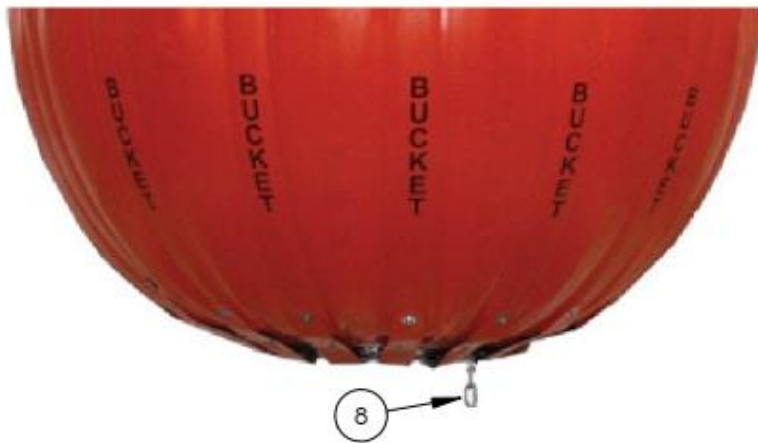
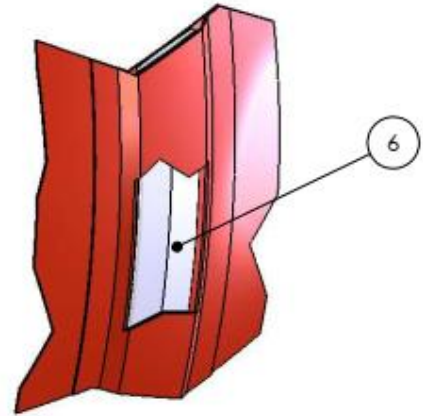
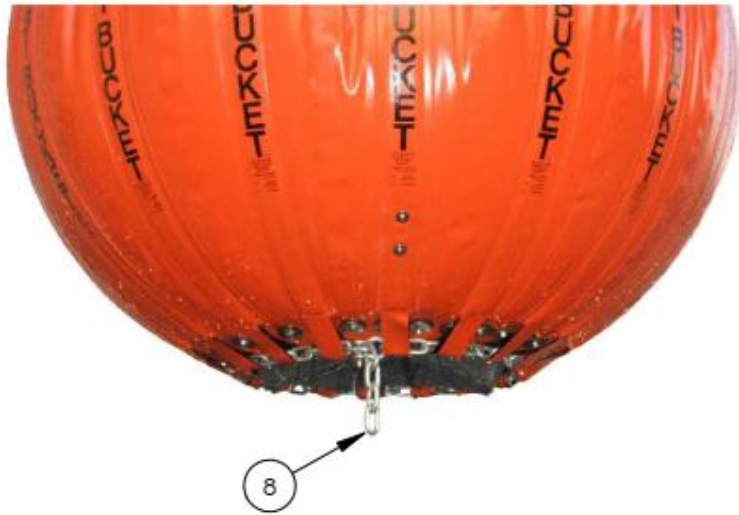

Section 9: Specifications and Parts

Bucket Shell – Battens, Wear Strips & Bottom Chain (continued)

ITEM	MODEL	PART #	DESCRIPTION	QTY
6	BBX1518	001102	BATTEN, 31-5/8"	16
	BBX1518S			
	BBX1821	001103	BATTEN, 34-3/4"	
	BBX1821S			
	BBX2024	005422	BATTEN, 35-1/2"	
	BBX2024S			
	BBX2226			
	BBX2226L	005424	BATTEN, 38-1/2"	
	BBX2732			
	BBX2732S			
	BBX3137	017172	BATTEN, 45-1/2"	
BBX3542	005425	BATTEN, 48-1/2"		
7	BBX2024	007778	STRIP, WEAR, ASSY	16
	BBX2024S			
	BBX2226			
	BBX2226L			
	BBX2732			
	BBX2732S			
	BBX3137	007638		
BBX3542				
8	BBX1518	007683	CHAIN, BOTTOM, 3/16" X 60", ASSY	1
	BBX1518S			
	BBX1821			
	BBX1821S			
	BBX2024	007206	CHAIN, BOTTOM, 3/16" X 72", ASSY	
	BBX2024S			
	BBX2226			
	BBX2226L			
	BBX2732			
	BBX2732S			
	BBX3137			
	BBX3542			

Section 9: Specifications and Parts

Bucket Shell – Ballast Assembly

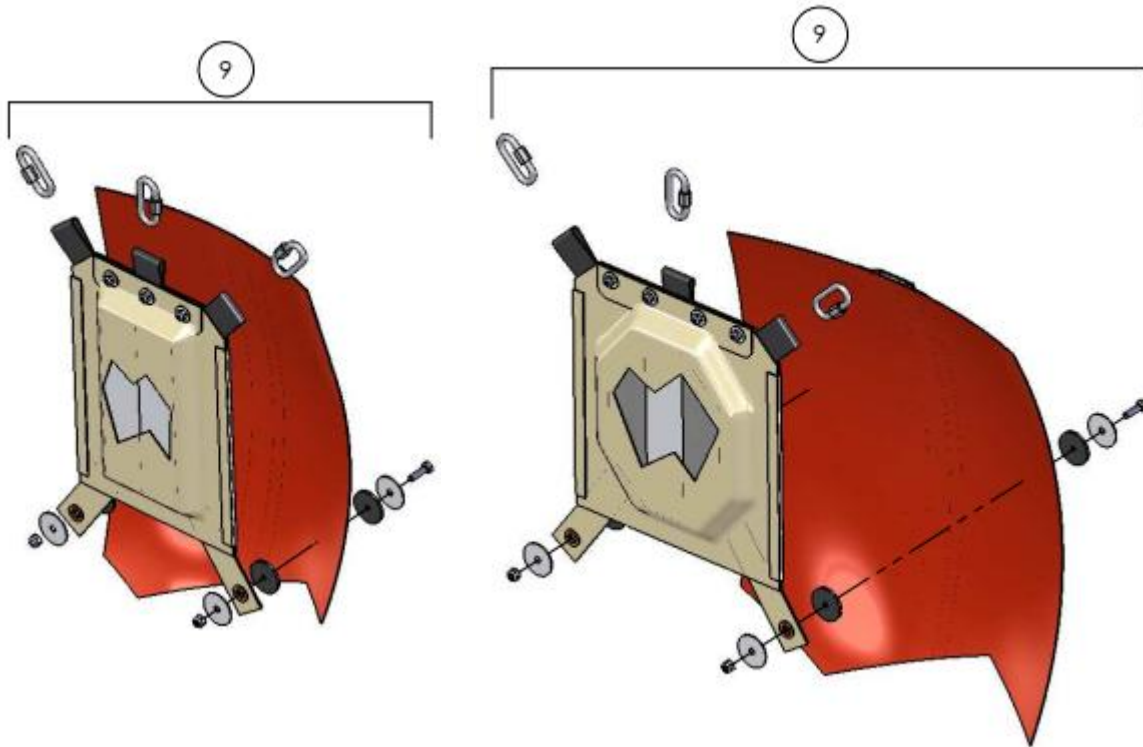

ITEM	MODEL	PART #	DESCRIPTION	QTY
9	BBX1518	006184	BALLAST, ASSY	1
	BBX1518S			
	BBX1821	006185		
	BBX1821S			
	BBX2024	006186		
	BBX2024S			
	BBX2226			
	BBX2226L	006187		
	BBX2732			
	BBX2732S			
	BBX3137			
	BBX3542			

Section 9: Specifications and Parts

Bucket Shell – Valve Guard & Rings

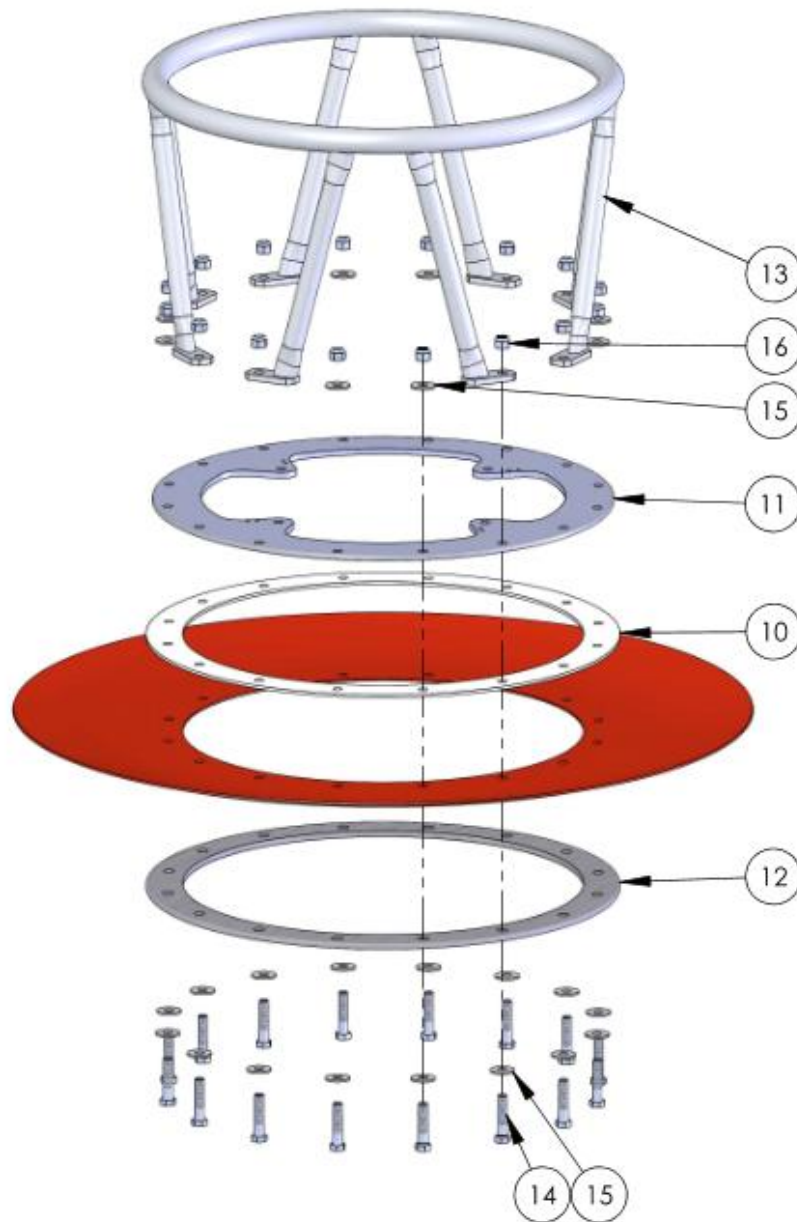

ITEM	MODEL	PART #	DESCRIPTION	QTY
10	ALL	004226	GASKET, SHELL, 16"	1
11		007138	RING, BASE, 16"	1
12		007141	RING, CLAMP, 16"	1
13		006881	GUARD, VALVE, 16",	1
14		000393	BOLT, HEX, 3/8-16 X 1-3/4, SS	16
15		001863	WASHER, FLAT, 0.38 X 1.00 X 0.080, SS	24
16		001665	NUT, HEX, NYLOCK, 3/8-16, SS	16

Section 9: Specifications and Parts

Bucket Shell – Shell Bracket Assembly

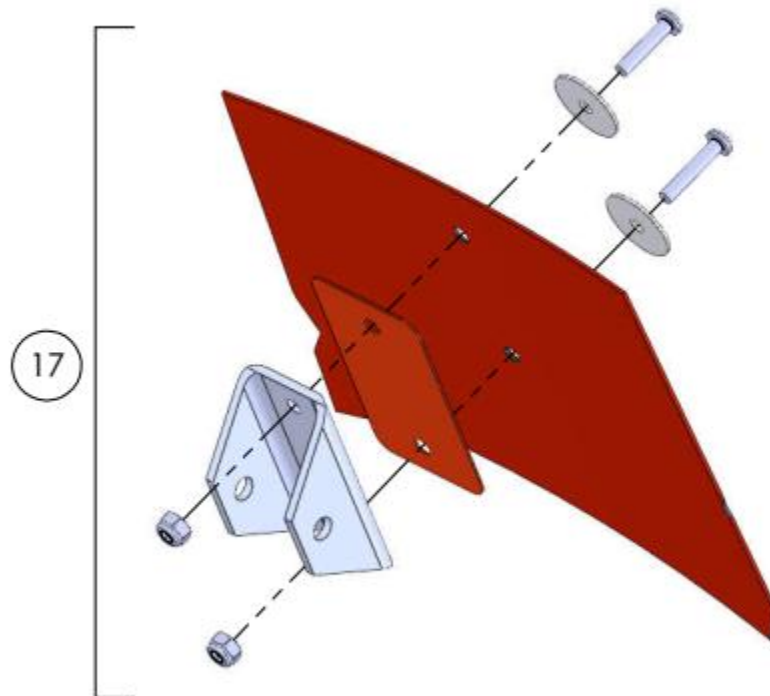

ITEM	MODEL	PART #	DESCRIPTION	QTY
17	BBX1518	014906	BRACKET, SHELL, ASSY	8
	BBX1518S			
	BBX1821			
	BBX1821S			
	BBX2024	014907		
	BBX2024S			
	BBX2226			
	BBX2226L			
	BBX2732			
	BBX2732S			
	BBX3137			
	BBX3542			

Section 9: Specifications and Parts

Valve Attachment

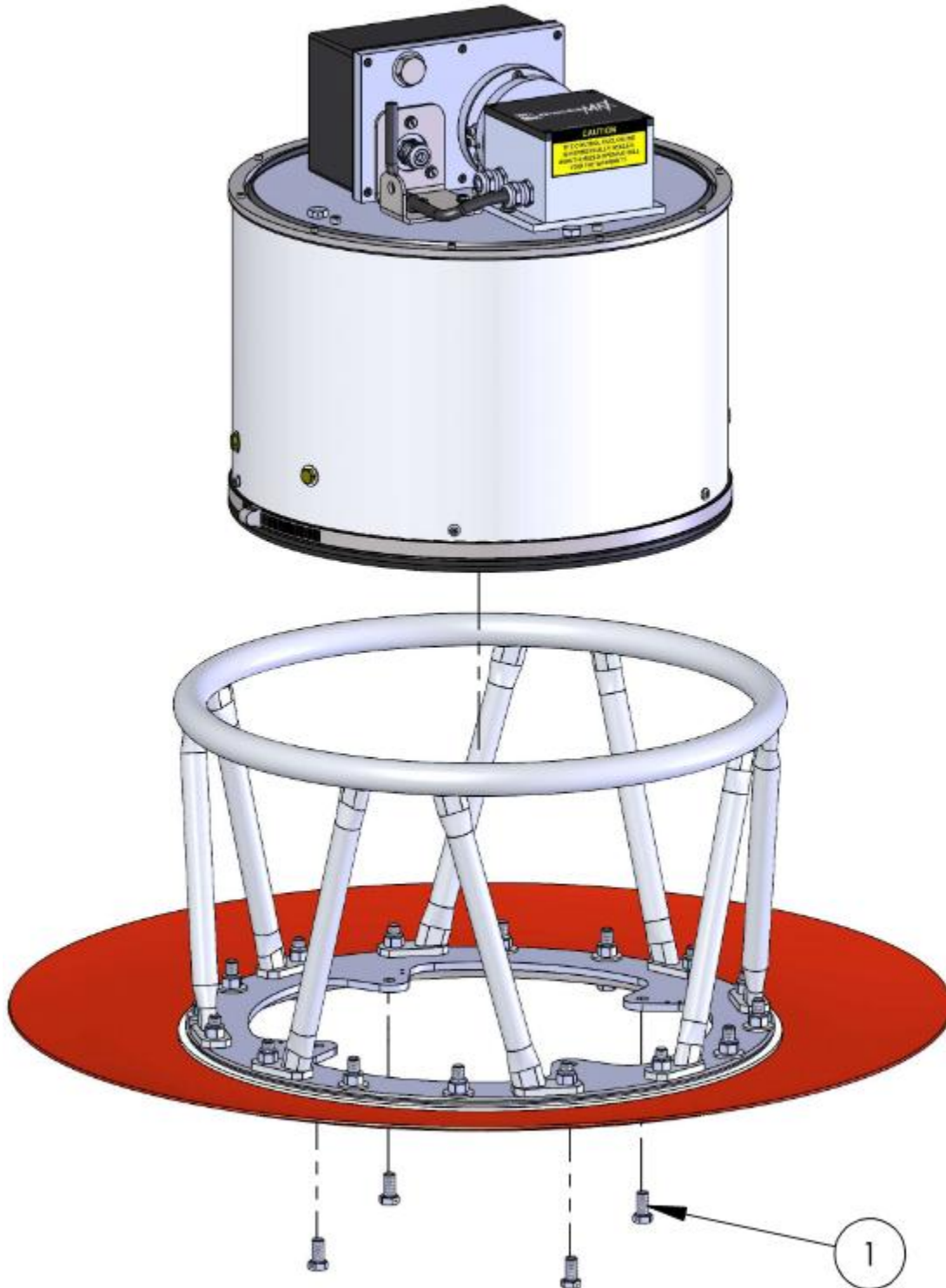

Section 9: Specifications and Parts

ITEM	MODEL	PART #	DESCRIPTION	QTY
1	ALL	018142	BOLT, HEX, 3/8-16 x 3/4, LOCK, SS	4

Section 9: Specifications and Parts

Valve

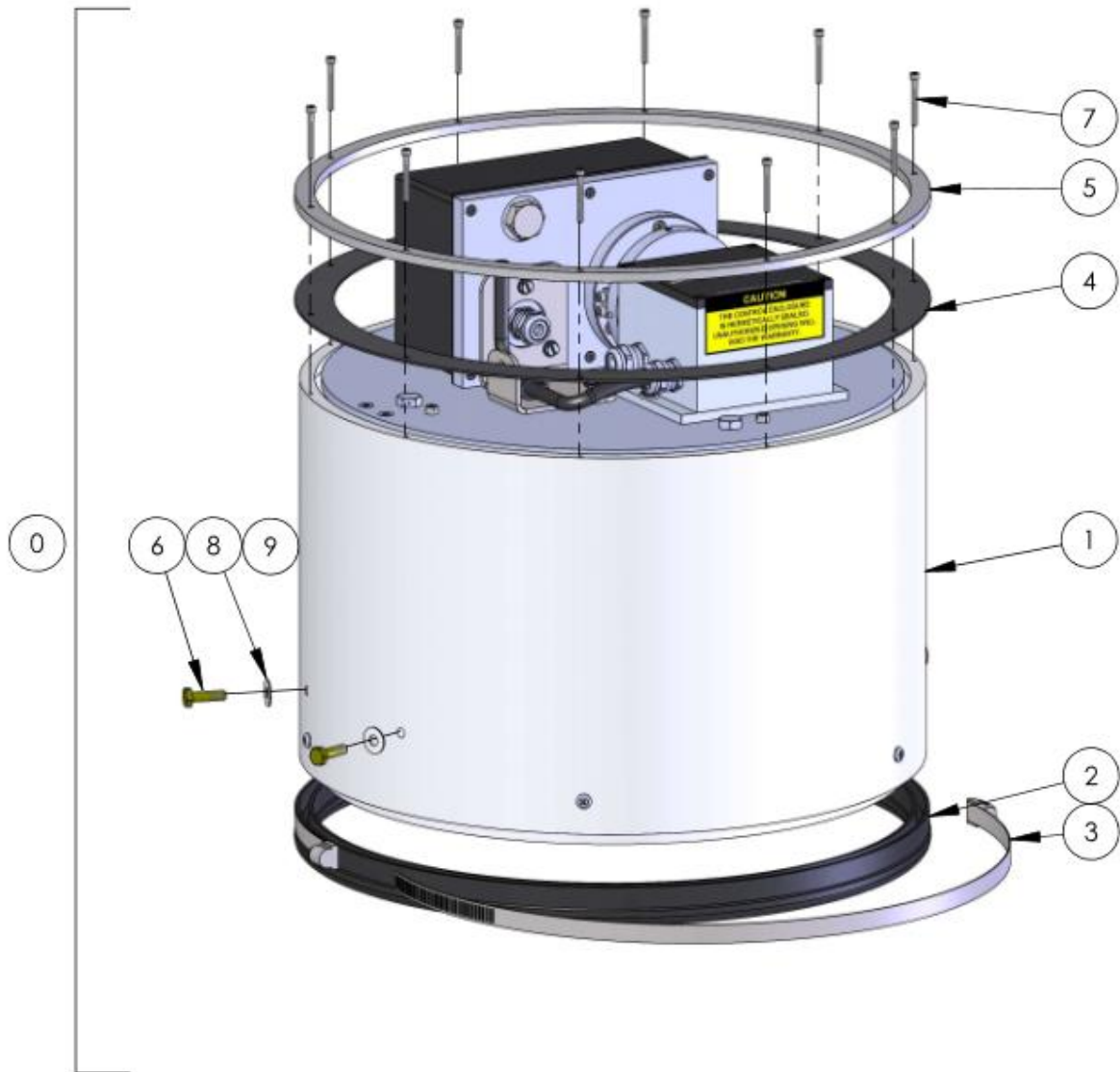

Section 9: Specifications and Parts

Valve (continued)

ITEM	MODEL	PART #	DESCRIPTION	QTY
0	ALL	002298	VALVE, 16", ASSY	1
1	ALL	016301	TUBE, VALVE, 16", PART ASSY	1
2		016866	SEAL, VALVE, BOTTOM, 16", EPDM	1
3		011522	CLAMP, GEAR, 8" SS	2
4		006321	SEAL, VALVE, TOP, 16"	1
5		007335	RING, SEAL, TOP 16"	1
6		000009	BOLT, HEX, 1/4-28 X 29/32, CAD	4
7		000416	SCREW, SC, 6-32 X 1-1/4" SS	10
8		001833	WASHER, FLAT, 0.28 X 0.69 X 0.036	4
9		001688	NUT, HEX, NYLOCK, 1/4-28, SS	4

Section 9: Specifications and Parts

Valve – IVC Assembly

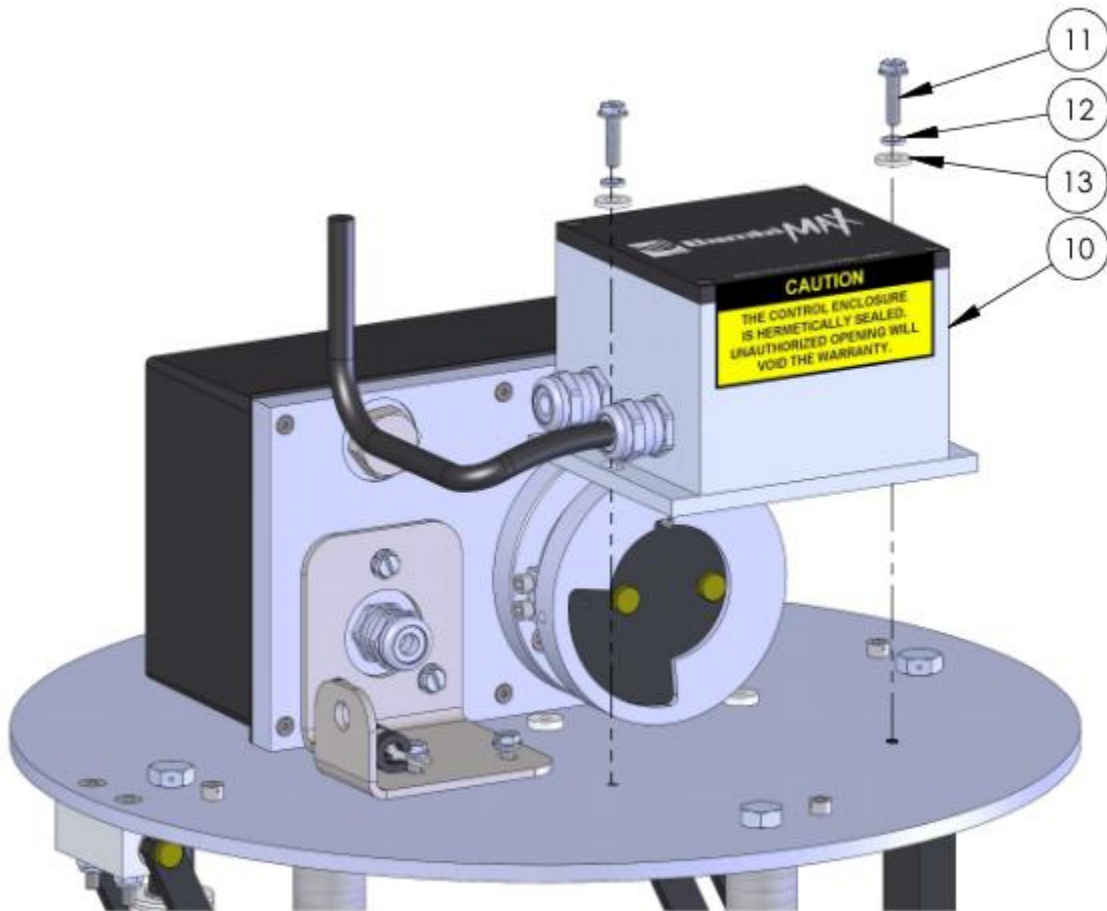

ITEM	MODEL	PART #	DESCRIPTION	QTY
10	ALL	010596	IVC, ASSEMBLY	1
11		001606	SCREW, 10-24 X 3/4, HXSL, SS	2
12		001848	WASHER, LOCK, SPLIT, #10, SS	2
13		001843	WASHER FLT, #10, SAE, SS	2

Section 9: Specifications and Parts

Valve – Motor Assembly

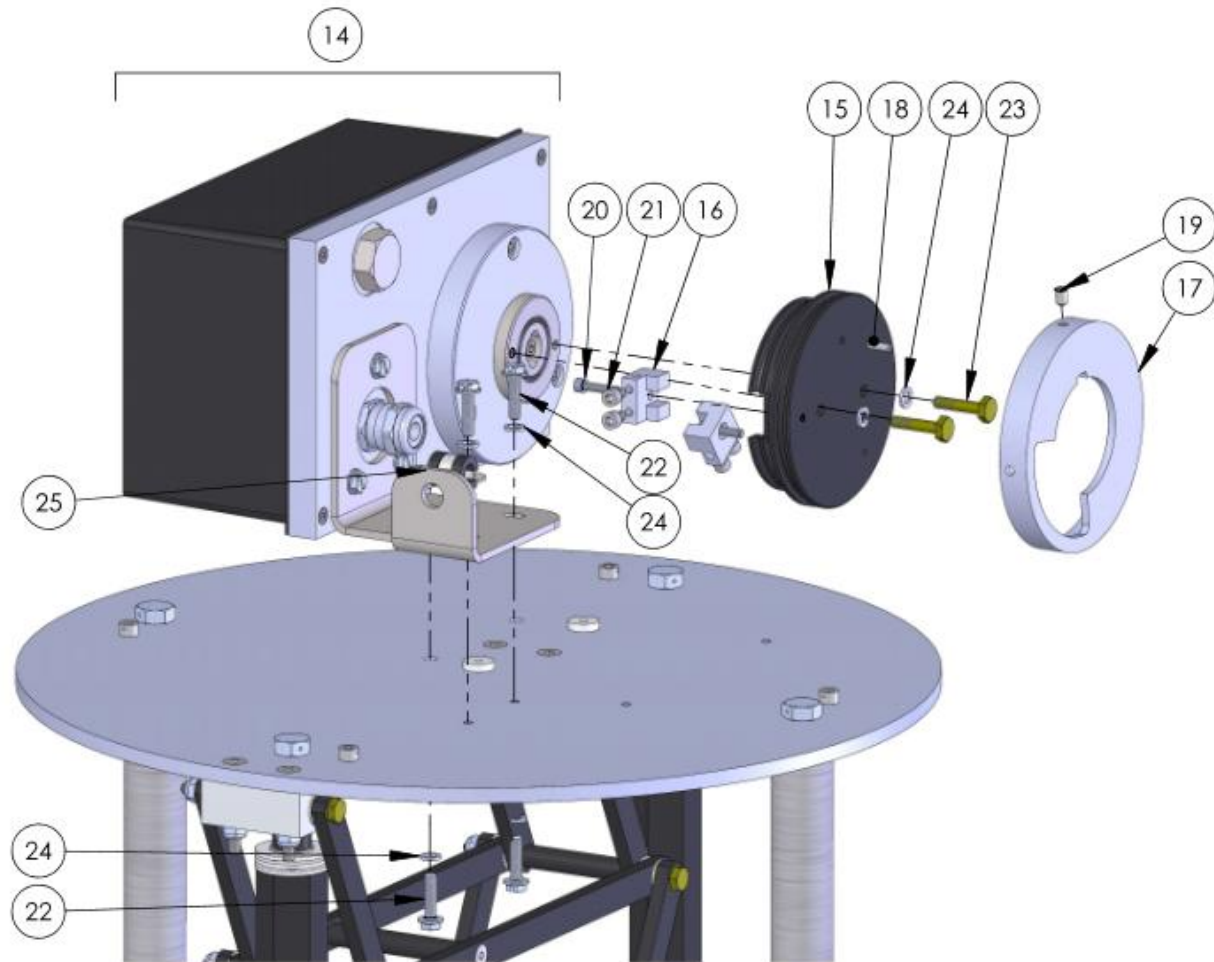

ITEM	MODEL	PART #	DESCRIPTION	QTY
14	ALL	015279	MOTOR, ASSY, 16"	1
15		015270	DRUM, CABLE, 1/8"	1
16		015271	ANCHOR, CABLE	2
17		000222	CAM, SENSOR	1
18		001734	PIN, SPLIT, 1/8 X 3/8, SS	1
19		010735	SCREW, SET, CUP, NYL, 10-32 X 1/4, SS	1
20		000413	SCREW, SC, 6-32 X 5/8, SS	2
21		015287	SCREW, SC, 8-32 X 1/4, SS	4
22		001606	SCREW, 10-24 X 3/4, HXSL, SS	4
23		000281	BOLT, HX, 10-32 X 29/32, CAD	2
24		001848	WASHER, LOCK, SPLIT, #10, SS	4
25		016136	CLAMP, CABLE, 5/16"	1

Section 9: Specifications and Parts

Valve – Sheave Bar & Guide Rods

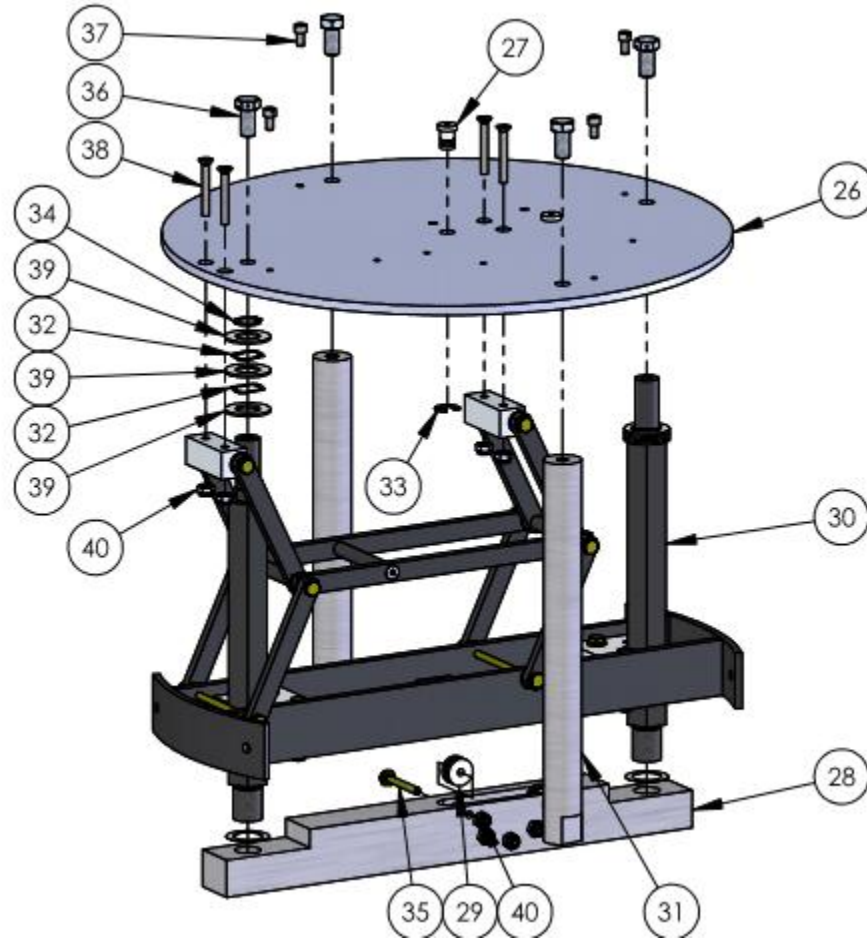

ITEM	MODEL	PART #	DESCRIPTION	QTY
26	ALL	015274	PLATE, TOP, 16"	1
27		015273	BUSHING, CABLE	2
28		000226	BAR, SHEAVE, 16"	1
29		001617	SHEAVE, CABLE	5
30		000231	ROD, GUIDE	2
31		000229	ROD, SUPPORT	2
32		007107	SPRING, DISC, 0.650 X 0.855 X 0.060, SS	4
33		015283	RING, RETAINER, EXT, 3/8" PLT	2
34		005214	RING, RETAINER, EXT, 5/8", SS	2
35		000012	BOLT, HEX, 10-32 X 1-17/32, CAD	5
36		018142	BOLT, HEX, FLG, 3/8-16 X 3/4, LOCK, SS	4
37		018143	SCREW, SC, 10-24 X 3/8, LOCK, SS	4
38		002241	SCREW, FSC, 10-32 X 1-1/2, SS	4
39		006276	WASHER, FLAT, 0.64 X 1.19 X 0.060, SS	6
40		001685	NUT, HEX, NYLOCK, 10-32, SS	9

Section 9: Specifications and Parts

Valve – Lift Bar & Linkage

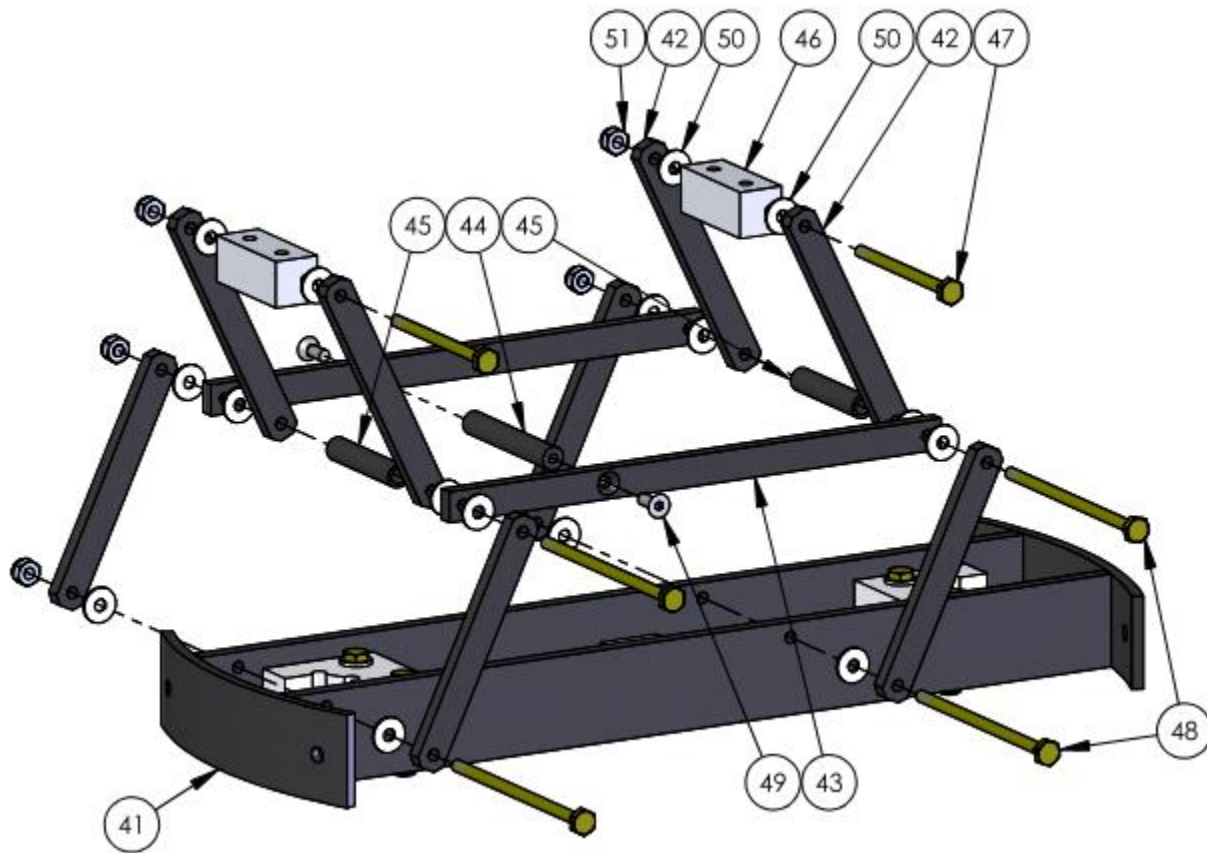

ITEM	MODEL	PART #	DESCRIPTION	QTY
41	ALL	000233	BAR, LIFT, 16"	1
42		008660	ARM, LINKAGE, SHORT, 16"	8
43		008662	ARM, CARRIER, SHORT, 16"	2
44		008664	SPACER, SOLID, CARRIER	1
45		008874	SPACER, TUBE, CARRIER	2
46		008665	BLOCK, PIVOT	2
47		001755	BOLT, HEX, 10-32 X 2-25/32, CAD	2
48		001771	BOLT, HEX, 10-32 X 3-29/32, CAD	4
49		000449	SCREW, 10-24 X 1/2, FSC, SS	2
50		002269	WASHER, FLAT, 0.20 X 0.57 X 0.40, PTFE	16
51		001685	NUT, HEX, 10-32, SS	6

THIS PAGE INTENTIONALLY LEFT BLANK

Section 9: Specifications and Parts

Valve – Guide Bushings & Drive Cable

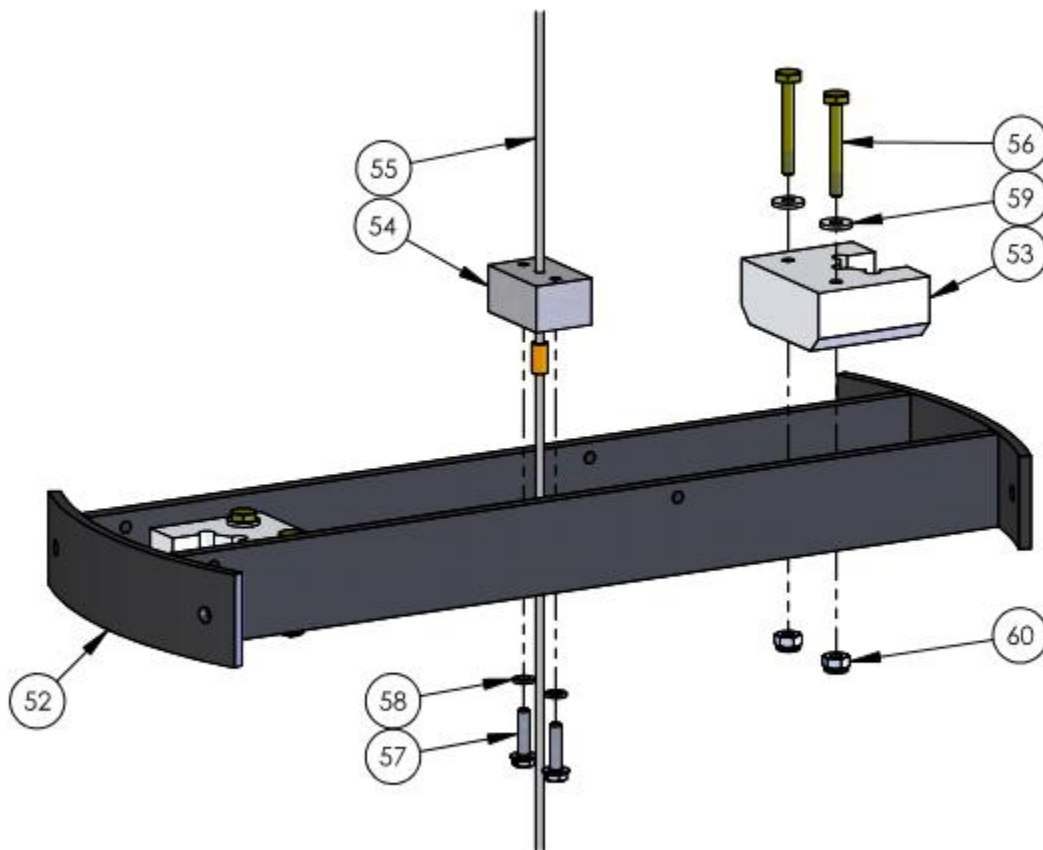

ITEM	MODEL	PART #	DESCRIPTION	QTY
52		000233	BAR, LIFT, 16"	1
53		000236	BUSHING, GUIDE, 16"	2
54		015272	RETAINER, CABLE, 1/8"	1
55		015282	CABLE, DRIVE, 1/8", ASSY	1
56	ALL	000012	BOLT, HEX, 10-32 X 1-17/32, CAD	4
57		001606	SCREW, 10-24 X 3/4, HEXSL, SS	2
58		001848	WASHER, LOCK, SPLIT, #10, SS	2
59		001843	WASHER, FLAT, 0.20 X 0.50 X 0.6, SS	4
60		001685	NUT, HEX, NYLOCK, 10-32, SS	4

Section 9: Specifications and Parts

Instant Deployment System (IDS Models 1518-3542)

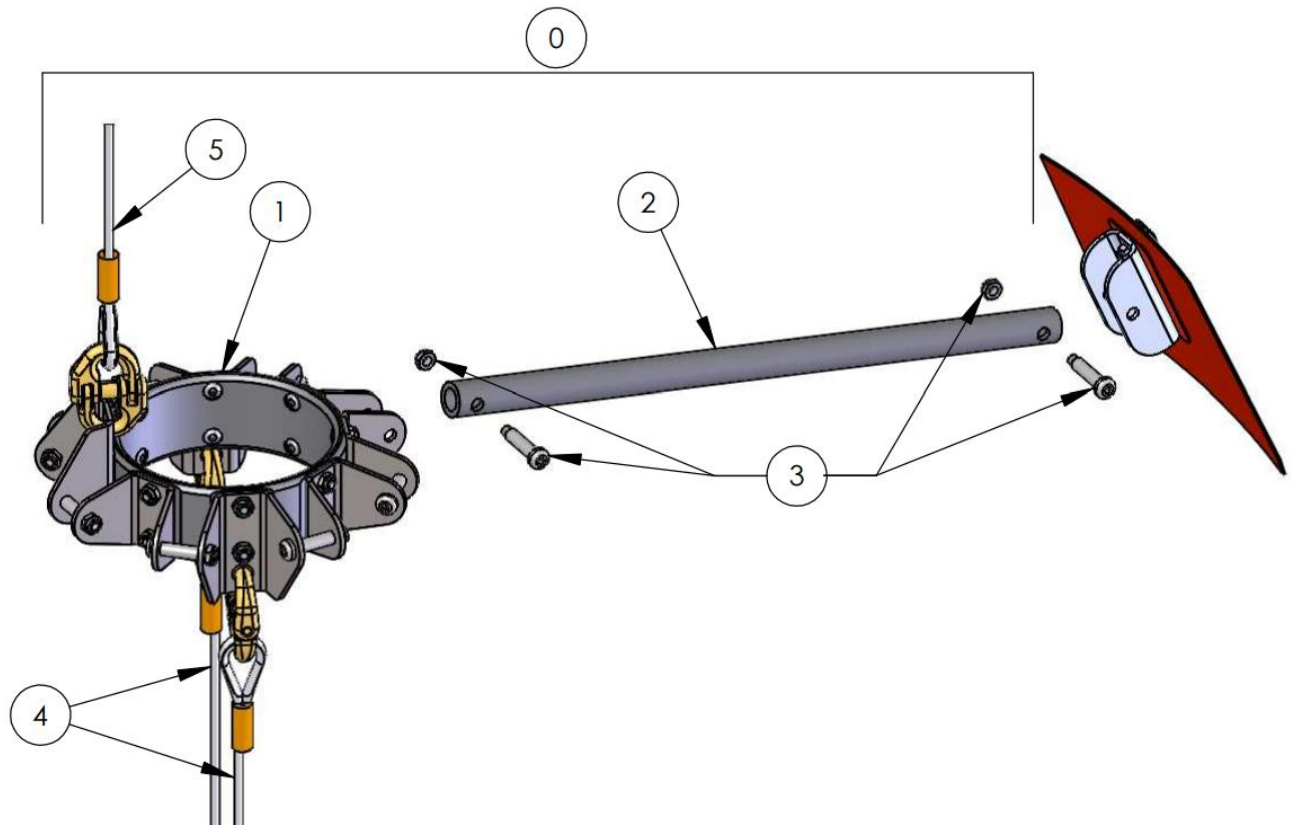

ITEM	MODEL	PART #	DESCRIPTION	QTY
0	BBX1518	005397	IDS, ASSY	1
	BBX1821	005397		
	BBX2024	005398		
	BBX2226	007695		
	BBX2226L	019871		
	BBX2732	005400		
	BBX3137	017062		
	BBX3542	005401		

Section 9: Specifications and Parts

Instant Deployment System (IDS) (continued)

ITEM	MODEL	PART #	DESCRIPTION	QTY
1	BBX1518	005367	HUB/CABLE, ASSY	1
	BBX1821			
	BBX2024	005374		
	BBX2226L			
	BBX2226	007224		
	BBX2732	005376		
	BBX3137	017067		
	BBX3542	005377		
2	BBX1518	005342	SPOKE, SOLID, 17-1/2"	8
	BBX1821			
	BBX2024	005343	SPOKE, TUBE, 16-3/4"	
	BBX2226	005344	SPOKE, TUBE, 19-3/8"	
	BBX2226L			
	BBX2732	005345	SPOKE, TUBE, 20"	
	BBX3137	017061	SPOKE, TUBE, 21"	
	BBX3542	005346	SPOKE, TUBE, 21-5/8"	
3	BBX1518	020237	HARDWARE, SPOKE, KIT	8
	BBX1821			
	BBX2024	019983	HARDWARE, SPOKE, KIT	
	BBX2226			
	BBX2226L			
	BBX2732			
	BBX3137			
	BBX3542			
4	BBX1518	019647	CABLE, IDS, RESTRAINER, W/BACKET	2
	BBX1821			
	BBX2024	019648		
	BBX2226			
	BBX2226L			
	BBX2732	019649		
	BBX3137	019650		
	BBX3542	019651		

Section 9: Specifications and Parts

Instant Deployment System (IDS) (continued)

ITEM	MODEL	PART #	DESCRIPTION	QTY
5	BBX1518	019666	CABLE, IDS, DEPLOYMENT, W/BRACKET	1
	BBX1821			
	BBX2024	019668		
	BBX2226L			
	BBX2226	019667		
	BBX2732	019669		
	BBX3137			
	BBX3542			

Section 9: Specifications and Parts

Head Harness Cable Clips

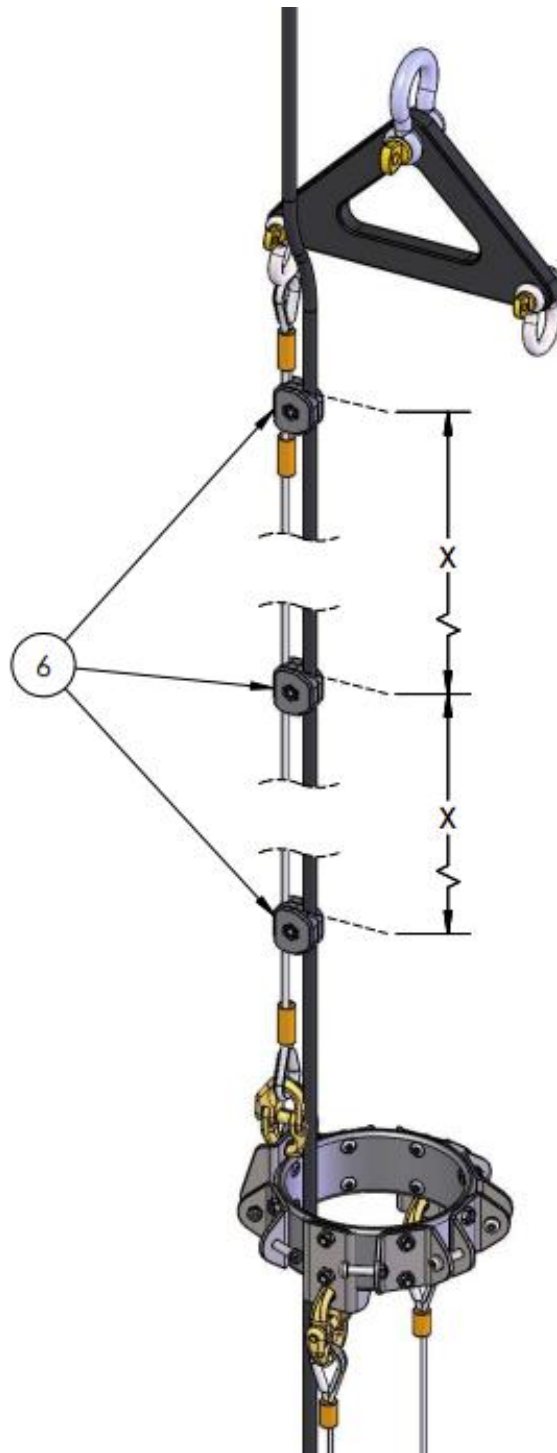

Section 9: Specifications and Parts

Head Harness Cable Clips (continued)

ITEM	MODEL	PART #	DESCRIPTION	QTY
6	BBX1518	019173	CLIP, CABLE, HEAD HARNESS, ASSY	5
	BBX1821			
	BBX2024			6
	BBX2226L			
	BBX2226			4
	BBX2732			
	BBX3137			7
	BBX3542			

MODEL	SPACING BETWEEN CLIPS "X"
BBX1518	27.50"
BBX1821	
BBX2024	28.50"
BBX2226L	
BBX2226	29.50"
BBX2732	28.25"
BBX3137	
BBX3542	28.0"

Section 9: Specifications and Parts

Carry Bag

MODEL	PART #	DESCRIPTION
BBX1518	005598	CARRY BAG
BBX1821		
BBX2024	005602	
BBX2226		
BBX2226L		
BBX2732		
BBX3137		
BBX3542		

Spares Kit

MODEL	PART #	DESCRIPTION	CONTENTS
ALL	009930	SPARES, BAMBI MAX, KIT	SEAL, VALVE, BOTTOM, 16" (1) SEAL, VALVE, TOP, 16" (1) BUSHING, GUIDE (2) CABLE, DRIVE, ASSEMBLY (1) CLAMP, GEAR, 8, SS (2)

Shell Repair Supplies

MODEL	PART #	DESCRIPTION
ALL	003613	KIT, REPAIR, SHELL
	018339	PATCH, FABRIC, 8" X 10"
	014858	PATCH, FABRIC, BULK, 24" X 68"
	004502	CLAMP, REPAIR, SMALL
	004503	CLAMP, REPAIR, MEDIUM
	004504	CLAMP, REPAIR, LARGE
	003090	ADHESIVE, AQUASEAL, 3/4 OZ
	003091	ADHESIVE, AQUASEAL, 8 OZ

NOTICE

It is the responsibility of the end user to ensure that the importation of glue is allowed in the country of use.

Section 9: Specifications and Parts

Shell Repair Kit

Repair kits contain some of the tools needed to perform repairs on Bambi MAX Bucket shells. Urethane adhesive is **not included** in this kit. Urethane adhesive can be purchased separately.

Contents of 003613 – KIT, REPAIR, SHELL:

PART #	DESCRIPTION	QTY
011161	BAG, TOOL	1
003661	FABRIC REPAIR MANUAL	1
003608	BAG, WEIGHT	1
003064	PAD, ABBRASIVE	2
003071	ROLLER, SEAM, 1 ¼	1
003074	SCISSORS	1
004502	CLAMP, REPAIR, SMALL, (2" HOLE)	1
018339	PATCH, FABRIC, 8"x10", 34OZ, PTFE	3
002383	BAG, ZIPLOCK, 9" x 12", 2M	2



THIS PAGE INTENTIONALLY LEFT BLANK

Section 10: Drawings

Pilot Controls

RECOMMENDED COMPONENTS

ITEM	DESCRIPTION	SPECIFICATION
CB1	CIRCUIT BREAKER, 10A	MS22073-10
K1	RELAY, SPST, 10A	MS24149F
S1	SWITCH, SPST, MOMENTARY	MS24523-2B
J1	CONNECTOR, RECEPTACLE	NEMA 5-15R
P1	CONNECTOR, PLUG	NEMA 5-15P
J2	CONNECTOR, RECEPTACLE, IP67	NEMA 5-15R, IP67
P2	CONNECTOR, PLUG, IP67	NEMA 5-15P, IP67
---	WIRE, #20 AWG	MS22759/16-20
---	WIRE, #16 AWG	MS22759/16-16
---	WIRE, #12 AWG	MS22759/16-12

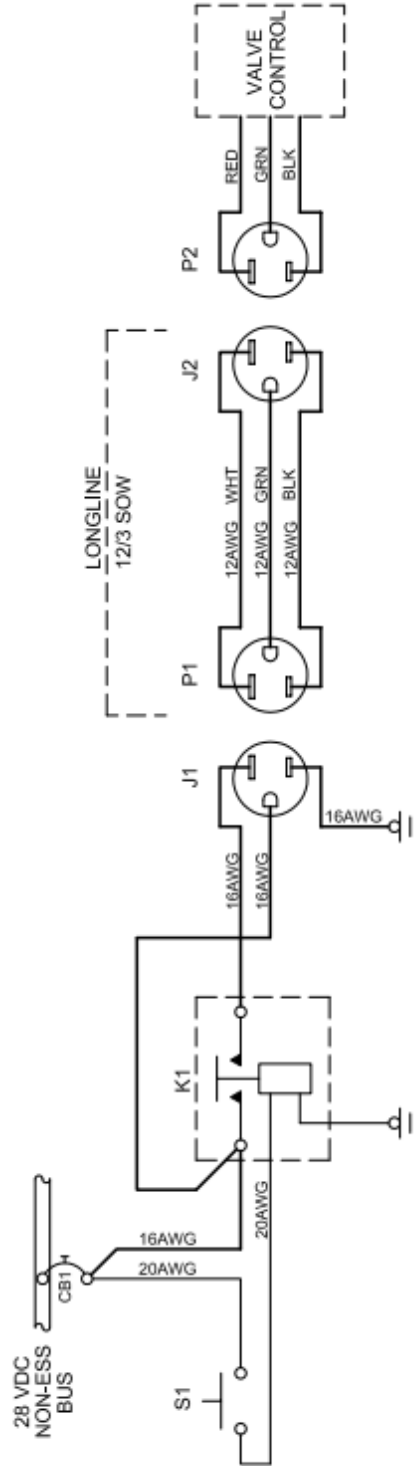

NOTES

1. THESE ARE RECOMMENDED INSTALLATION INSTRUCTIONS ONLY. ALL INSTALLATIONS TO BE DONE BY QUALIFIED PERSONNEL IN ACCORDANCE WITH APPLICABLE LOCAL REGULATIONS.
2. CONNECTION TO AIRCRAFT POWER SUPPLY DONE IN ACCORDANCE WITH FAA ADVISORY CIRCULAR AC43.13-1B AND AC43.12-2A. DO NOT CONNECT THE Bambi SYSTEM TO ANY AIRCRAFT BUS BAR THAT IS USED FOR EMERGENCY OR ESSENTIAL LOADS. AMMEND THE AIRCRAFT ELECTRICAL LOAD ANALYSIS TO ENSURE THAT THE GENERATOR CAPACITY IS ADEQUATE TO OPERATE THE SYSTEM.
3. ALL GROUNDS, SOLDERED TERMINALS, AND CRIMPED TERMINALS DONE IN ACCORDANCE WITH AIRCRAFT MANUFACTURER'S INSTRUCTIONS.

Section 10: Drawings

Pilot Controls, US Interagency

RECOMMENDED COMPONENTS

ITEM	DESCRIPTION	SPECIFICATION
CB1	CIRCUIT BREAKER, 5A	MS22073-5
CB2	CIRCUIT BREAKER, 50A	MS24571-50
K1	RELAY, SPST, 50A	MS24166-D1
S1	SWITCH, SPST, MOMENTARY	MS24523-28
J1	CONNECTOR, RECEPTACLE	MS3101E-24-11S
P1	CONNECTOR, PLUG	MS3107B-24-11P
J2	CONNECTOR, RECEPTACLE, IP67	NEMA 5-15R, IP67
P2	CONNECTOR, PLUG, IP67	NEMA 5-15P, IP67
---	WIRE, #20 AWG	MS22759/16-20
---	WIRE, #8 AWG	MS22759/16-8
---	WIRE, #12 AWG	MS22759/16-12

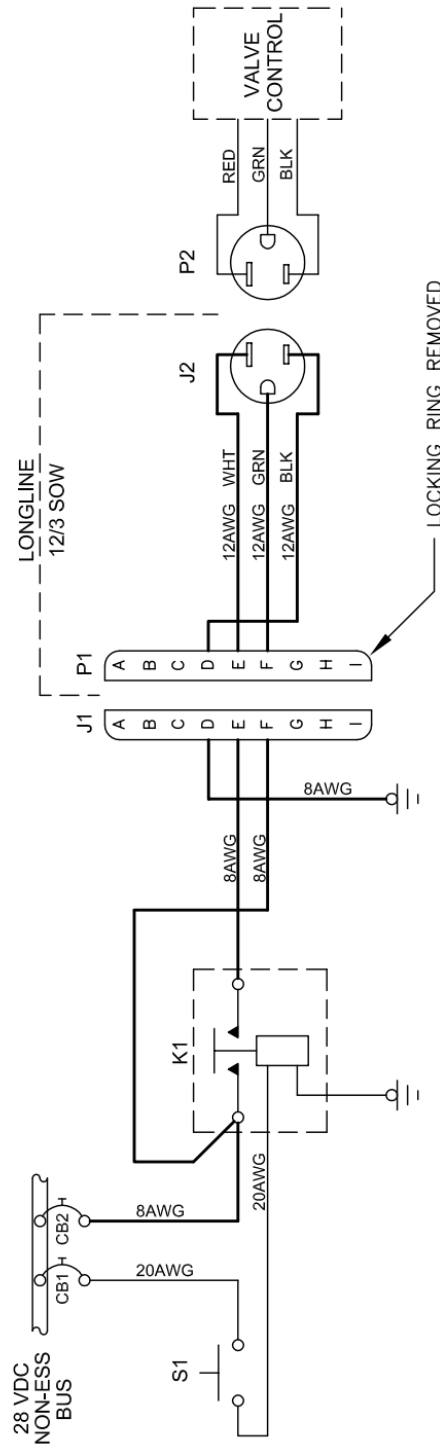

NOTES

1. THESE ARE RECOMMENDED INSTALLATION INSTRUCTIONS ONLY. ALL INSTALLATIONS TO BE DONE BY QUALIFIED PERSONNEL IN ACCORDANCE WITH APPLICABLE LOCAL REGULATIONS.
2. CONNECTION TO AIRCRAFT POWER SUPPLY DONE IN ACCORDANCE WITH FAA ADVISORY CIRCULAR AC43.13-1B AND AC43.12-2A. DO NOT CONNECT THE BAMBI SYSTEM TO ANY AIRCRAFT BUS BAR THAT IS USED FOR EMERGENCY OR ESSENTIAL LOADS. AMMEND THE AIRCRAFT ELECTRICAL LOAD ANALYSIS TO ENSURE THAT THE GENERATOR CAPACITY IS ADEQUATE TO OPERATE THE SYSTEM.
3. ALL GROUNDS, SOLDERED TERMINALS, AND CRIMPED TERMINALS DONE IN ACCORDANCE WITH AIRCRAFT MANUFACTURER'S INSTRUCTIONS.
4. ACTUATION SWITCH MOUNTED ON THE COLLECTIVE PITCH LEVER. SWITCH MARKED "OPEN" AND SPRING-LOADED TO THE OFF POSITION.
5. IF USING THE BAMBI MAX WITH A POWERFILL SNORKEL, USE PINS A & B IN PLACE OF PINS D & F FOR THE BAMBI MAX ON THE 9 PIN CONNECTOR. THE POWERFILL SNORKEL MUST USE PINS D & F.

Section 10: Drawings

Crew Controls – External Power Supply

RECOMMENDED COMPONENTS

ITEM	DESCRIPTION	SPECIFICATION
P1	CONNECTOR, PLUG	NEMA 5-15P
J2	CONNECTOR, RECEPTACLE, IP67	NEMA 5-15R, IP67
P2	CONNECTOR, PLUG, IP67	NEMA 5-15P, IP67
—	WIRE, #20 AWG	MS22759/16-20
—	WIRE, #16 AWG	MS22759/16-16
—	WIRE, #12 AWG	MS22759/16-12

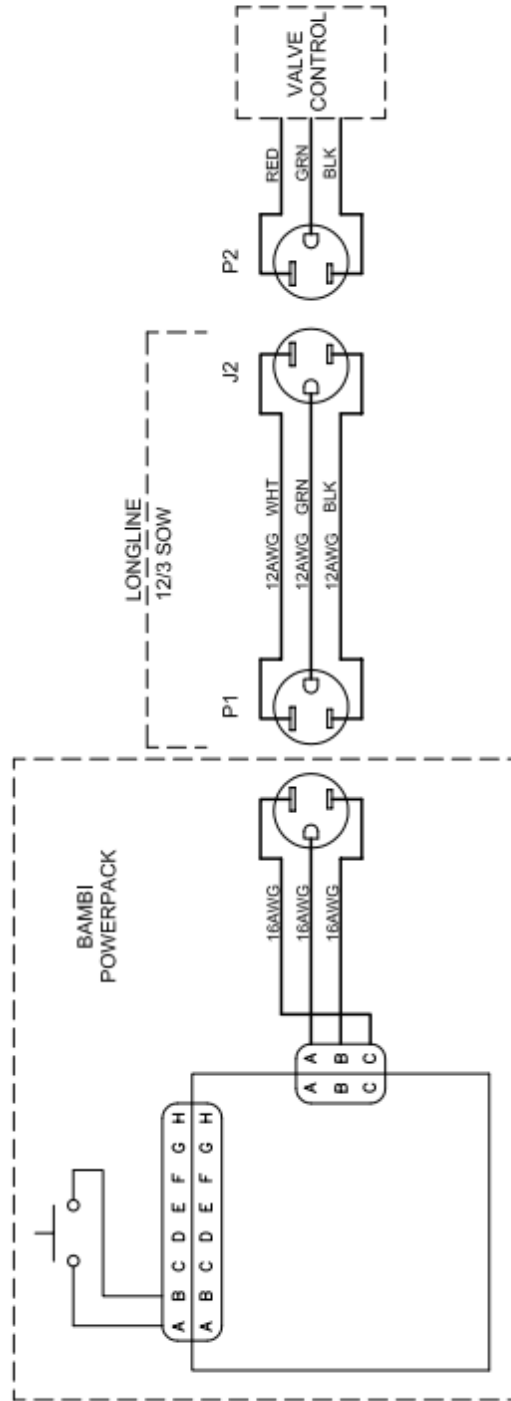

THIS PAGE INTENTIONALLY LEFT BLANK

Section 11: Warranty

Section 11: Warranty

SEI Industries Ltd. is an affiliate of Dart Aerospace:

- a) Limited Warranty on Products and Services can be found at <https://dartaerospace.com/pages/dart-warranty-return-policy>