



RED DRAGON

SERVICE MANUAL
2024A

RED DRAGON SERVICE MANUAL

**Version: 2024A
Part Number: 005854**

Maintenance Level: Organizational (O)

PLEASE READ BEFORE USING.

This manual is applicable to the following models:

DE002000 (#005851)

PATENTS

AU2014200904
CA2679269
US8776693

Copies of this manual are available from SEI.
The manual is available on the SEI website.
Register for manual update notifications at dragonupdate@sei-ind.com

SEI INDUSTRIES LTD.

7400 Wilson Avenue
Delta, B.C. Canada
V4G 1E5

Phone: (604) 946-3131
Fax: (604) 940-9566
seisales@sei-ind.com
www.sei-ind.com

Revision Summary

Version	Release Date	Revision Description	Pages	App.
2007A	Dec-2007	<ul style="list-style-type: none"> Initial Release 	-	MDT
2010B	Sep-2010	<ul style="list-style-type: none"> Changed tank caps Added glycol filters Added water filter Changed hopper linkage Removed motor relay 	19, 28 18, 20 27, 29 9, 65, 108	MDT
2013B	July-2013	<ul style="list-style-type: none"> Revised format 	-	MDT
2015C	Feb-2015	<ul style="list-style-type: none"> Added warranty details Added MSDS appendix 	117 118	MDT
2016C	Aug-2016	<ul style="list-style-type: none"> Added patent numbers 	-	MDT
2018D	Jan-2018	<ul style="list-style-type: none"> Changed tank caps 	22, 32	MDT
2023A	Apr-2023	<ul style="list-style-type: none"> Changed water check valves Changed drive motor, mount, coupling, & hardware 	33 14, 18, 88, 89, 90	MDT
2024A	16-Dec-2024	<ul style="list-style-type: none"> Updated Warranty Section 	115	AS

VALIDATION OF OPERATIONS DESCRIBED IN THIS MANUAL

The maintenance operations described in this manual have been checked in manufacturer's workshops by an exact carrying out of dismantling, reassembly, test and repair instructions which are detailed in this document.

These operations are those in use at the latest revision date of the document.

Table of Contents

Section 1: Introduction	1
Manual Overview.....	1
Section 2: Sphere Handling System	3
Description.....	3
Sphere System Components	7
Sphere System Troubleshooting	16
Section 3: Glycol System	21
Description.....	21
Glycol System Components.....	22
Glycol System Troubleshooting.....	25
Section 4: Water System	31
Description.....	31
Water System Components.....	32
Water System Troubleshooting.....	35
Section 5: Control System	37
Control System Operation.....	37
Control System Components	45
Control System Troubleshooting	50
Section 6: Repairs for All Systems	75
Hopper Repairs	75
Feed Gate Repairs	80
Injection Head Repairs.....	88
Glycol System Repairs.....	92
Water System Repairs.....	97
Control System Repairs	103
Section 7: Supplier Cross Reference	111
Supplier Chart	111
Alternate Supplier Contacts	114
Section 8: Warranty	115
Appendix: Safety Data Sheet	117

Section 1: Introduction

Section 1: Introduction

Manual Overview

This service manual complements the Red Dragon operator's manual. It is intended to provide enough information so that all service required on the machine can be performed locally.

Manual Organization

The dispenser's functions have been organized into four major systems. Sections two through five in the manual correspond to each of these systems.

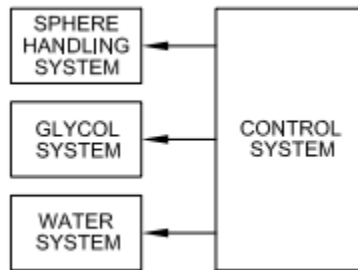

Each section begins with a description of how the components of the system operate. Following that description are expanded drawings that identify the system components in detail.

Finally, there are multiple troubleshooting procedures to identify common problems and offer possible solutions. Once a problem has been diagnosed, section six details the repair procedures for all systems. Section seven is a supplier cross reference for the non-proprietary parts used in the dispenser.

Skills Required

The service person needs to have an average mechanical aptitude and be competent in repairs with basic hand tools. He/she also needs to be able to operate a multi-meter to perform continuity and voltage measurements.

Tools Required

In addition to the tools provided in the Red Dragon tool kit, the following tools may also be required to perform troubleshooting and repairs.

- multi-meter with voltage and continuity ranges
- 0.050, 1/16, 5/64, 3/32, 7/64, 9/64, and 5/32 hex keys
- # 2 Phillips screwdriver
- 1/4, 11/32, 3/8 and 1/2 combination wrenches
- 10mm, 12mm, and 14mm combination wrenches

THIS PAGE INTENTIONALLY LEFT BLANK

Section 2: Sphere Handling System

Description

The purpose of the sphere handling system is to move the ignition spheres from the hopper, through the injection head, to exit the aircraft.

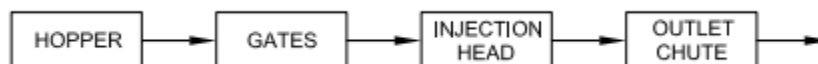

Hopper

The hopper is an open top container that stores the unprimed spheres. On the bottom of the hopper is an oscillating agitator which directs the spheres into one of two chutes. The lower ends of the chutes extend past the body of the hopper and connect to the top of the gate assembly.

There are spring loaded stops located at the exits of the chutes. When the hopper is removed from the gate assembly, these stops close to prevent the flow of spheres from the hopper. When the hopper is returned to the machine, pins located on the gate assembly open the hopper stops.

The hopper agitator is driven by a motor through a cam and linkage. Power to the hopper motor is supplied from the gate assembly via a multi-pin connector that automatically mates when the hopper is installed onto the gate assembly.

Gate

The gate assembly controls the flow of spheres from the hopper into the injection head. As the spheres exit the hopper, they enter two vertical sphere paths in the feed gate assembly. Each path is blocked by a feed gate. These are cylindrical pins attached to a common feed control rod. The position of the feed control rod and feed gates is controlled by two solenoids under direction from the microprocessor (see *Section 5: Control System*).

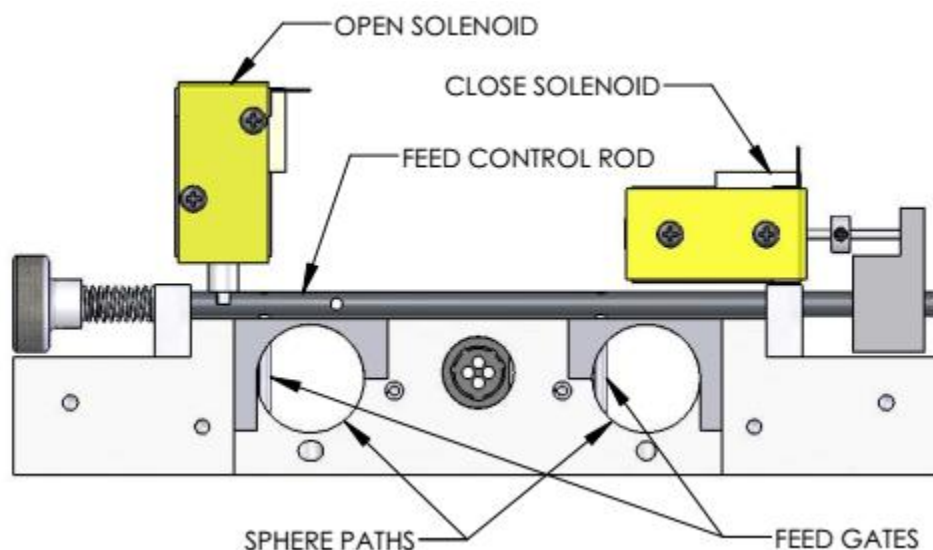

Section 2: Sphere Handling System

When the open solenoid is energized, it withdraws a spring loaded locking pin from the groove in the feed control rod. Once the feed control rod is unlocked, the feed rod spring forces the feed control rod to move outwards, unblocking the sphere paths.

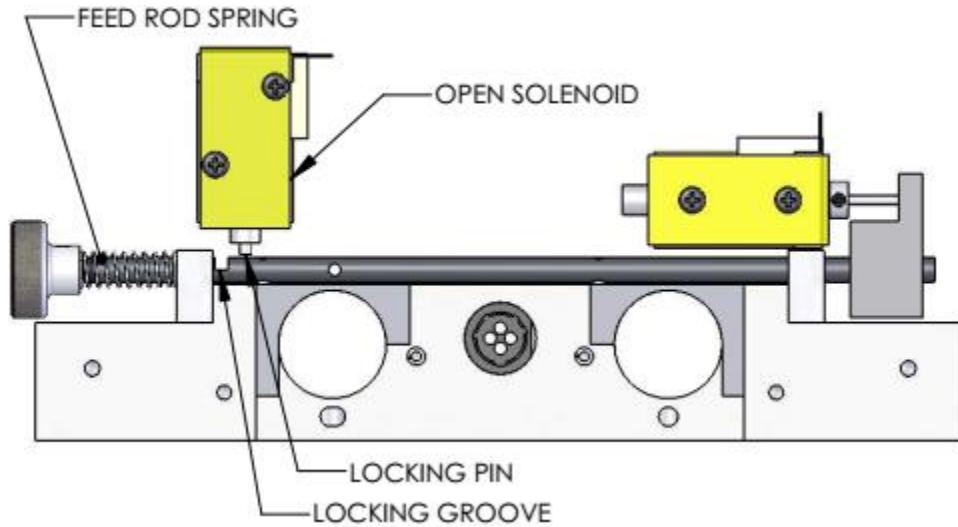

When the close solenoid is energized, it pushes the feed control rod inwards, causing the feed gates to block the flow of spheres through the passages. The spring loaded pin re-enters the groove in the feed control rod and locks the gates closed. In an emergency, the feed gate can be closed and locked by pushing the manual feed gate knob located on the end of the feed control rod.

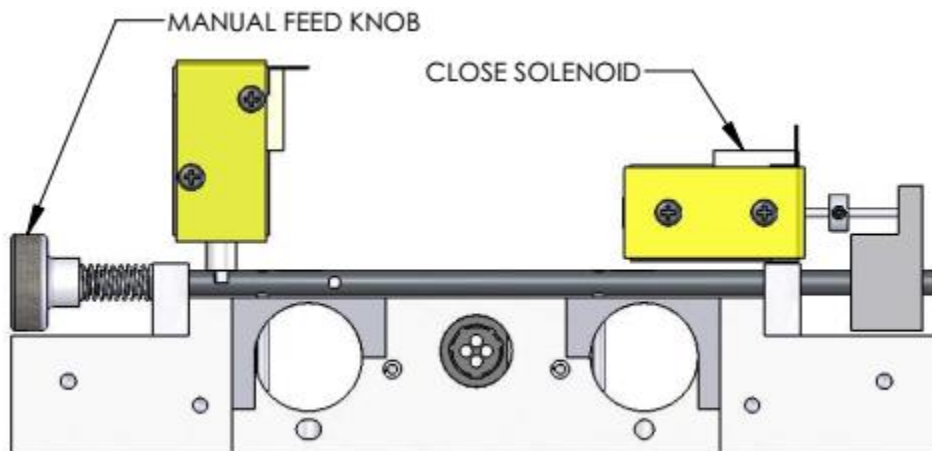

Section 2: Sphere Handling System

Injection Head

As a sphere exits the feed gate assembly, it falls into one of the cavities in the injection shuttle. The shuttle is driven in a reciprocating motion by the drive motor and the drive cam.

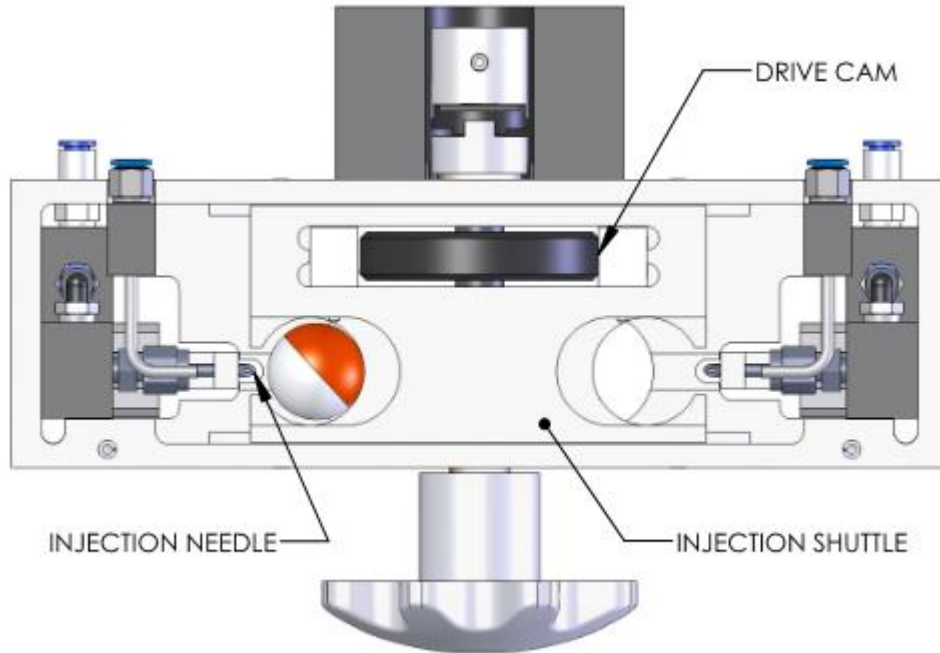

Outward motion of the shuttle causes the sphere to contact the injection needle and be injected with glycol. For details of the injection process, see *Section 3: Glycol System*.

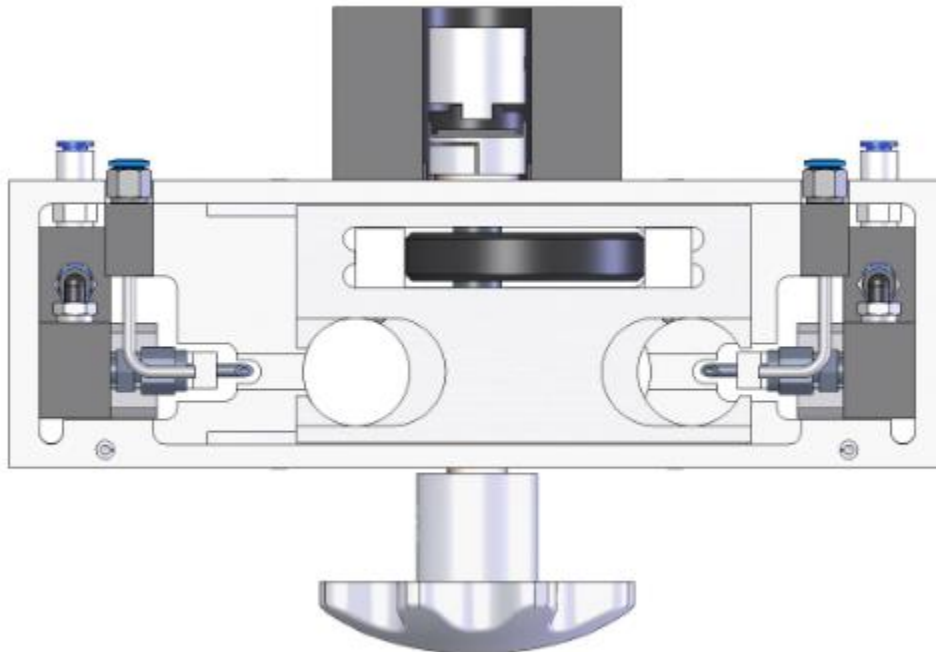

Section 2: Sphere Handling System

When the shuttle reverses direction, the sphere is extracted from the needle and transported to a point over the exit chute. The sphere falls through a hole in the bottom of the injection head and into the exit chute.

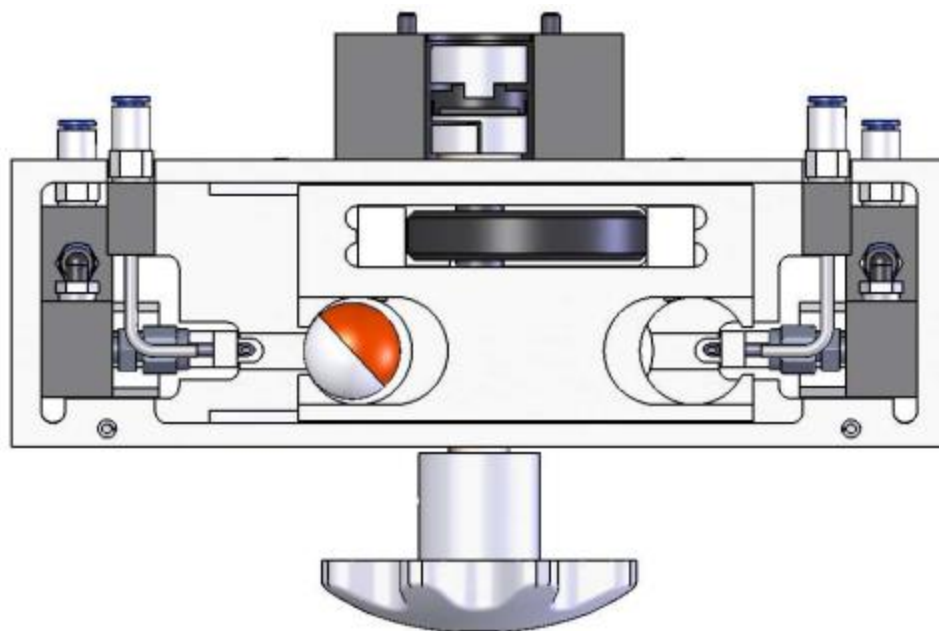

Exit Chute

The exit chute contains the spheres until they have reached a point below the aircraft to ensure that no live spheres enter the aircraft.

Sphere System Components

Hopper

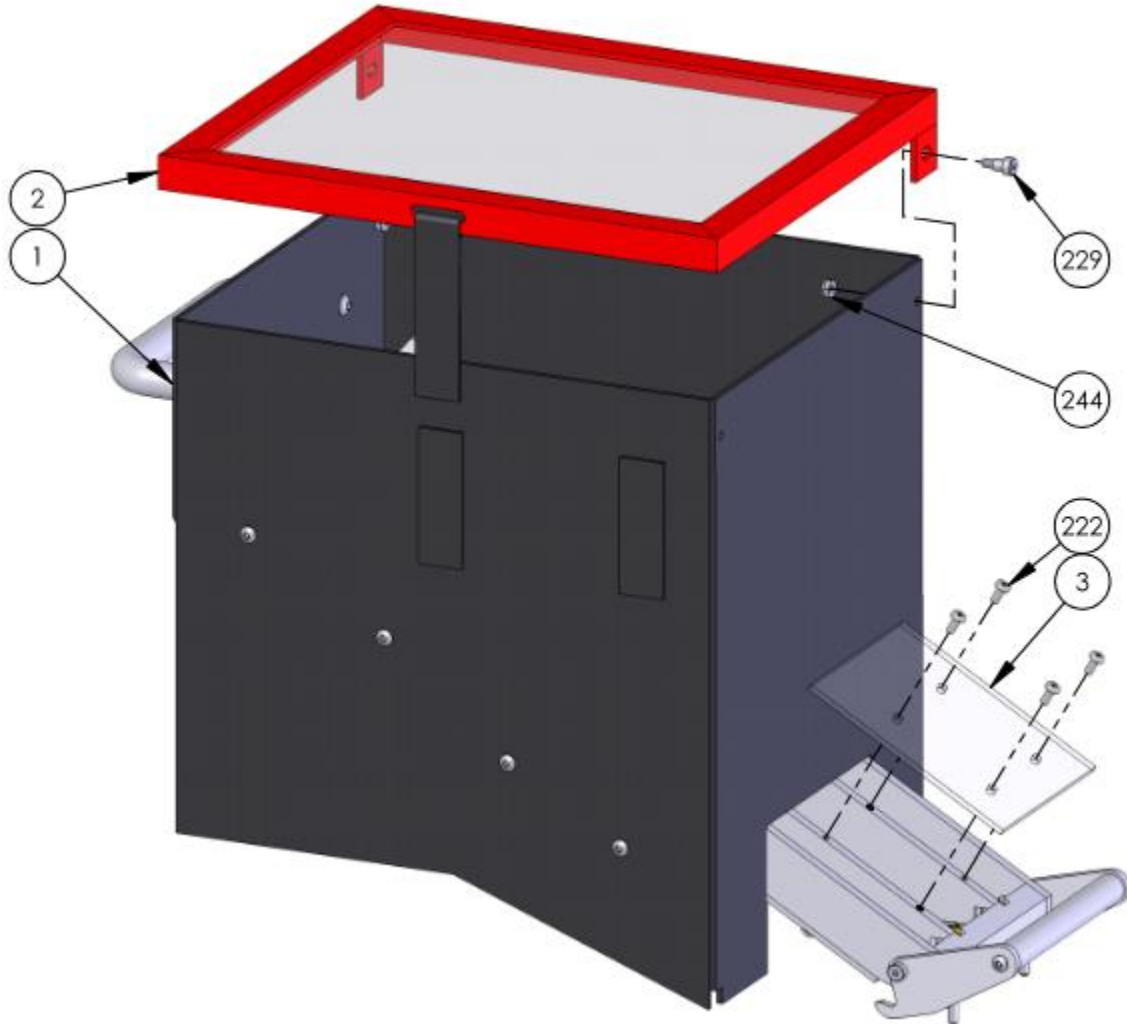

ITEM	PART #	DESCRIPTION	QTY
1	006017	HOPPER FABRICATION	1
2	006020	HOPPER LID	1
3	005946	CHUTE WINDOW	1
222	000487	MACHINE SCREW, PHILLIPS, SS, # 8-32 X 3/8	4
229	000553	SHOULDER BOLT, SS, 1/4 X 1/4 X # 10-32	2

Section 2: Sphere Handling System

Hopper (continued)

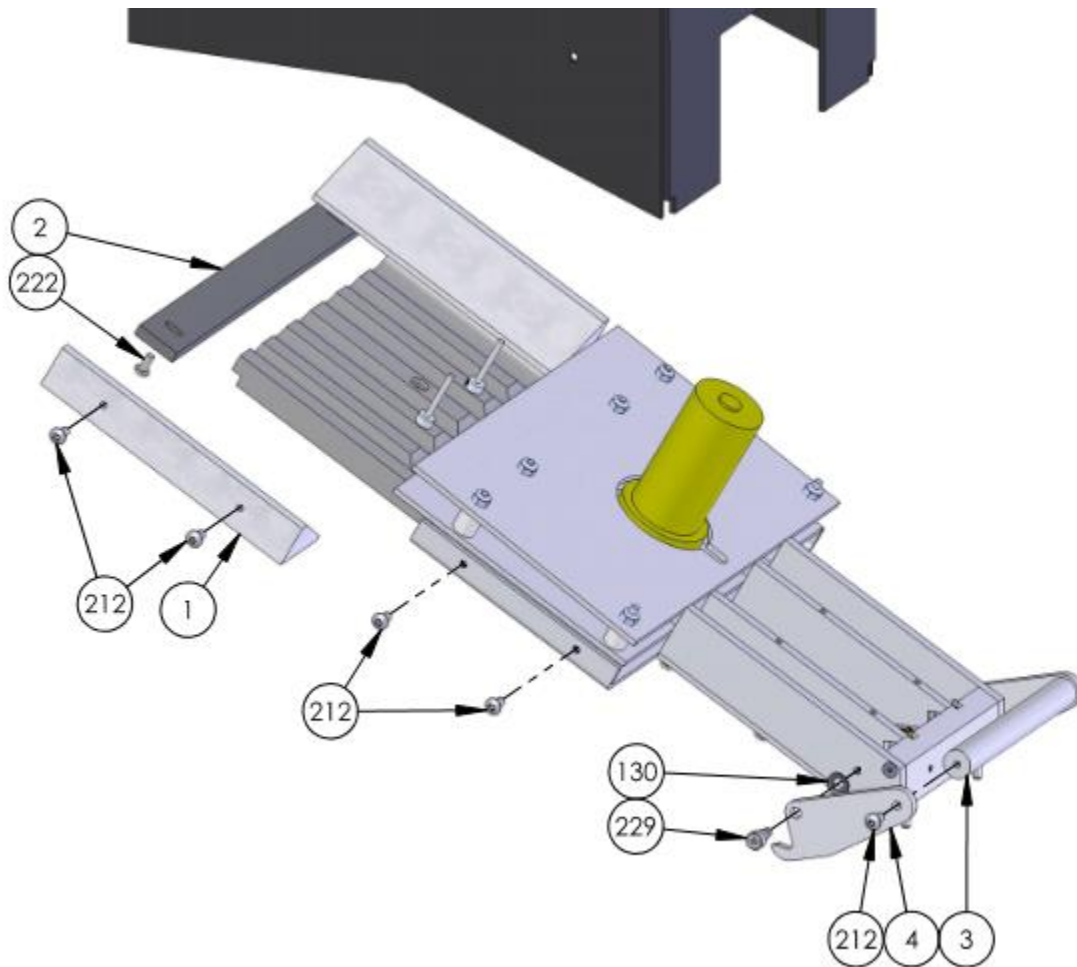

ITEM	PART #	DESCRIPTION	QTY
1	005938	HOPPER DEFLECTOR	2
2	006019	AGITATOR ADJUSTER	1
3	005954	LOCK HANDLE	1
4	005955	LOCK PLATE	2
130	005992	DISC SPRING	2
212	000513	BUTTON HEAD CAPSCREW, SS, # 10-24 X 3/8	8
222	000487	MACHINE SCREW, PHILLIPS, SS, # 8-32 X 3/8	2
229	000553	SHOULDER BOLT, SS, 1/4 X 1/4 X # 10-32	2

THIS PAGE INTENTIONALLY LEFT BLANK

Section 2: Sphere Handling System

Hopper (continued)

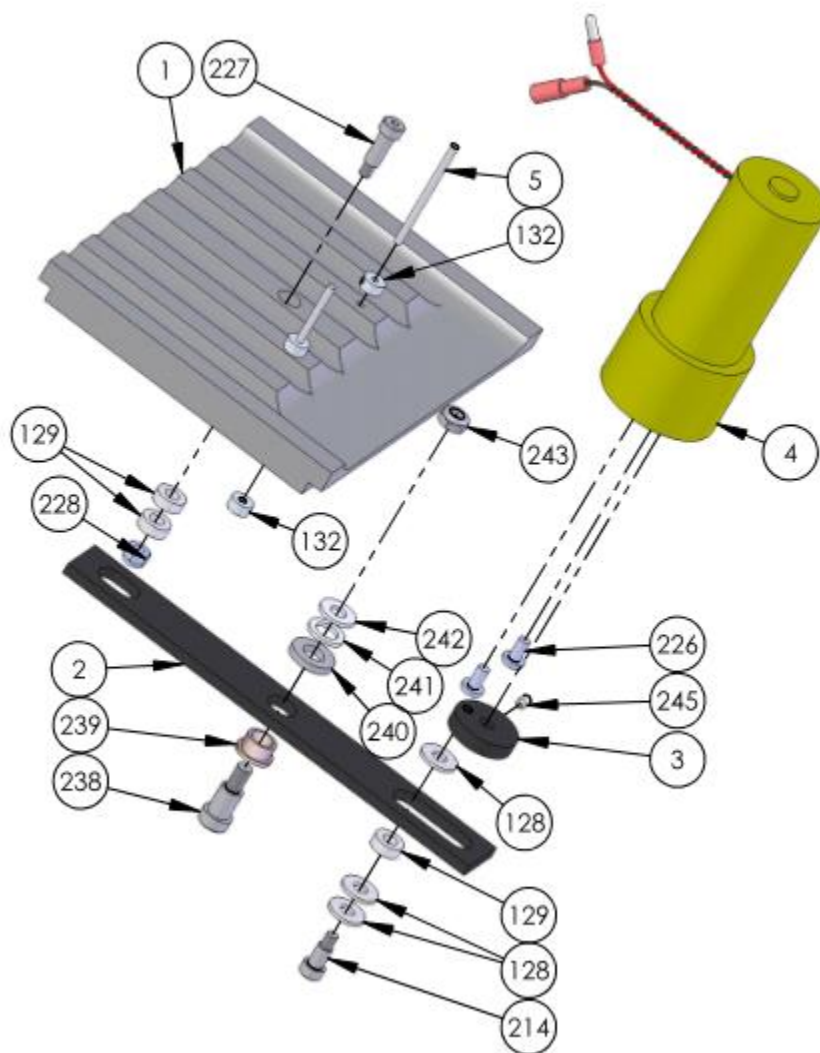

Section 2: Sphere Handling System

ITEM	PART #	DESCRIPTION	QTY
1	005939	AGITATOR PLATE	1
2	005940	AGITATOR LINKAGE	1
3	005941	AGITATOR CAM	1
4	005948	HOPPER MOTOR	1
5	001152	WHISKER, AGITATOR	2
128	005138	BUSHING, STRAIGHT, NYLON, 1/4 X 5/8 X 1/16	3
129	005985	BUSHING, STRAIGHT, NYLON, 1/4 X 1/2 X 3/16	3
132	010877	COLLAR, SHAFT, 1/8, SETSCREW	4
214	000554	SHOULDER BOLT, SS, 1/4 X 3/8 X # 10-32	1
226	000545	SCREW, 10-32 X 3/8, MS, PNP, SS	2
228	001685	NUT, NYLOCK, SS, 10-32	1
238	006411	BOLT, 3/8 X 1/2 X 1/4-20, SH, HX SS	1
239	005982	BUSHING, FL, BRZ, 3/8 X 1/2 X 5/16	1
240	006412	WASHER, FLT, 3/8 X 3/4, BRZ	1
241	001869	WASHER, FLT, 3/8 X 5/8, AN, SS	1
242	001819	WASHER, FLT, 1/4 X 5/8, SAE, SS	1
243	001663	NUT, JAM, NYL, 1/4-20, HX, SS	1
245	014125	SETSCREW, SS, #8-32 X 1/4, NYL	1
243	001663	NUT, JAM, NYL, 1/4-20, HX, SS	1

Section 2: Sphere Handling System

Gate Assembly

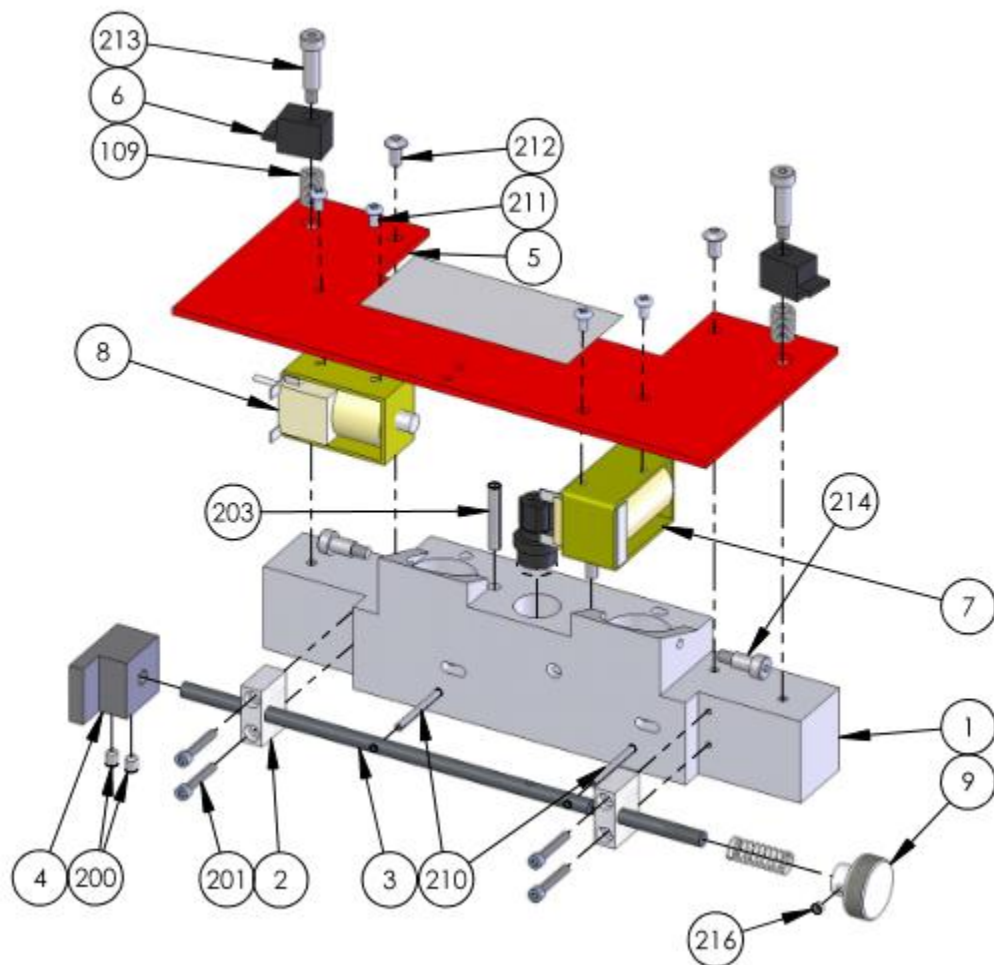

Section 2: Sphere Handling System

ITEM	PART #	DESCRIPTION	QTY
1	005910	GATE BLOCK	1
2	005911	PILLOW BLOCK	2
3	005912	FEED CONTROL ROD	1
4	005913	SOLENOID ACTIVATOR	1
5	005914	SOLENOID COVER	1
6	005915	GATE LOCK	2
7	005917	OPEN SOLENOID ASSY	1
8	005918	CLOSE SOLENOID ASSY	1
9	005919	MANUAL FEED CONTROL KNOB	1
109	005990	SPRING, PLATED	2
200	000525	SETSCREW, # 10-32 X 1/4	1
201	000414	SOCKET HEAD CAPSCREW, SS, # 6-32 X 7/8	4
203	001739	SPLIT PIN, SS, 3/16 X 1-1/4	2
210	001738	SPLIT PIN, SS, 1/8 X 1-1/4	2
211	011696	MACHINE SCREW, PANPHIL, SS, # 6-32 x 3/16	4
212	000513	BUTTON HEAD CAPSCREW, SS, # 10-24 X 3/8	2
213	000557	SHOULDER BOLT, SS, 1/4 X 3/4 X # 10-32	2
214	000554	SHOULDER BOLT, SS, 1/4 X 3/8 X # 10-32	2
216	000363	SETSCREW, # 8-32 X 1/8	1

Section 2: Sphere Handling System

Injection Head

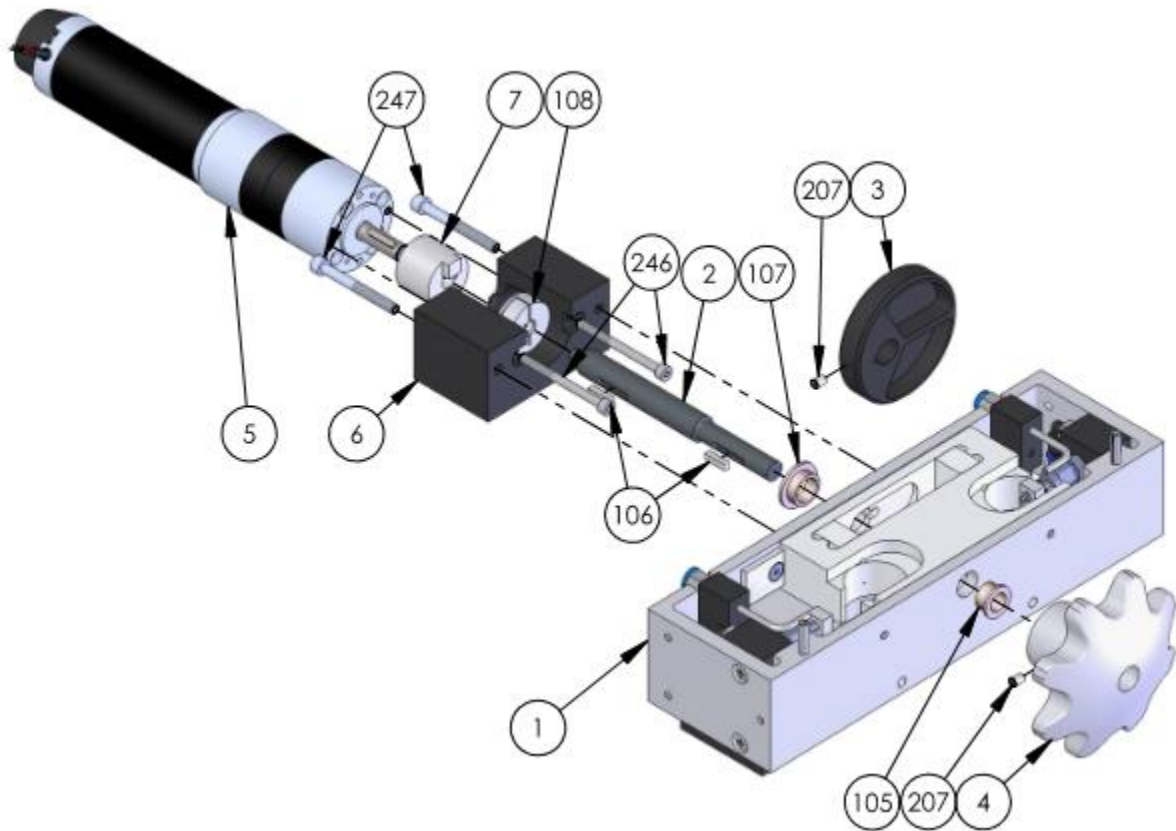

ITEM	PART #	DESCRIPTION	QTY
1	005888	INJECTION HEAD	1
2	005892	DRIVE SHAFT	1
3	014891	DRIVE CAM	1
4	005894	HAND WHEEL	1
5	005898	DRIVE MOTOR	1
6	005899	MOTOR MOUNT	1
7	017305	SHAFT COUPLING	1
105	005982	OILITE BUSHING, 3/8 X 1/2 X 5/16	1
106	015194	KEY, 1/8 X 1/8 X 1/2	2
107	005109	OILITE BUSHING, 1/2 X 5/8 X 1/4	1
108	005137	SHAFT COUPLING	1
207	014125	SETSCREW, #8-32 X 1/4, NYL	2
246	017339	SOCKET HEAD CAPSCREW, SS, M4X0.7 X 50	2
247	017349	SOCKET HEAD CAPSCREW, SS, #10-32 X 1-3/4	2

Section 2: Sphere Handling System

Injection Head (continued)

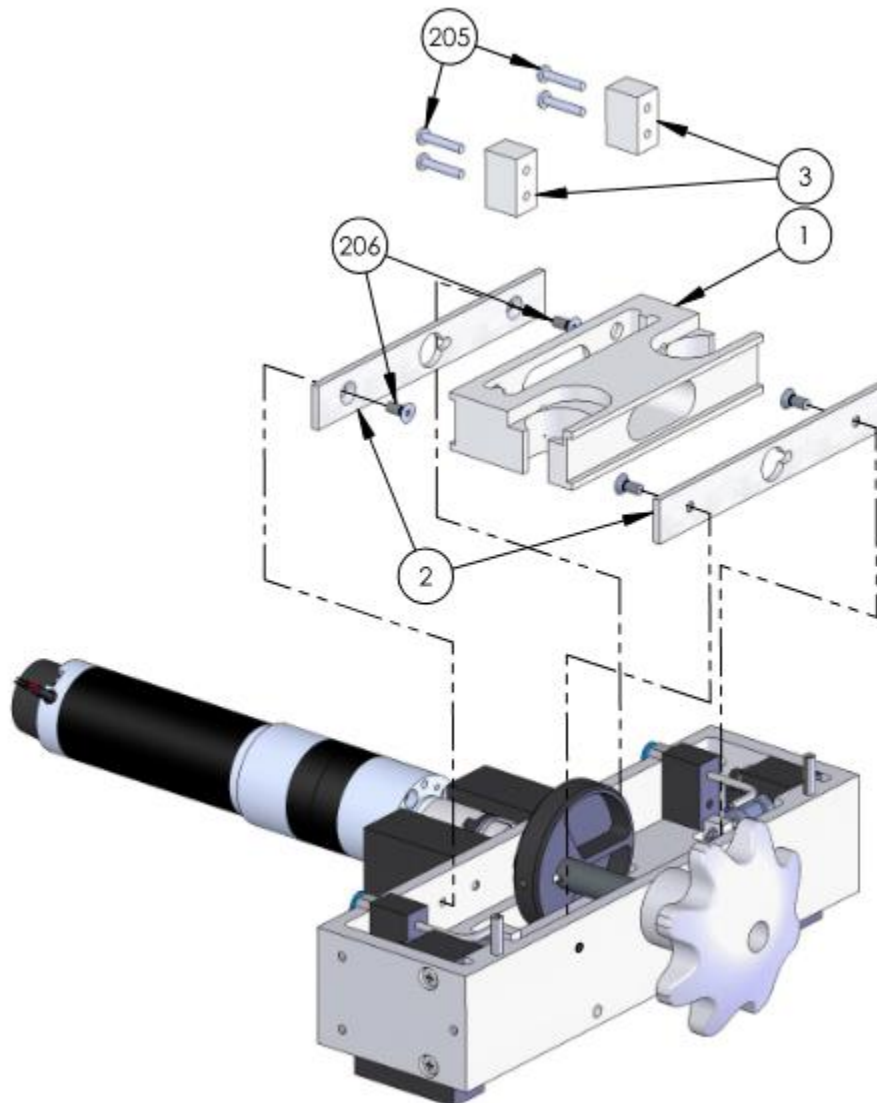

ITEM	PART #	DESCRIPTION	QTY
1	005889	INJECTION SHUTTLE	1
2	005890	SHUTTLE GUIDE	2
3	005891	CAM GUIDE	2
205	000484	MACHINE SCREW, PHILLIPS, SS, # 6-32 X 3/4	4
206	000442	MACHINE SCREW, FLAT SOC, SS, # 8-32 X 3/8	4

Sphere System Troubleshooting

Hopper Agitator Non-Operational

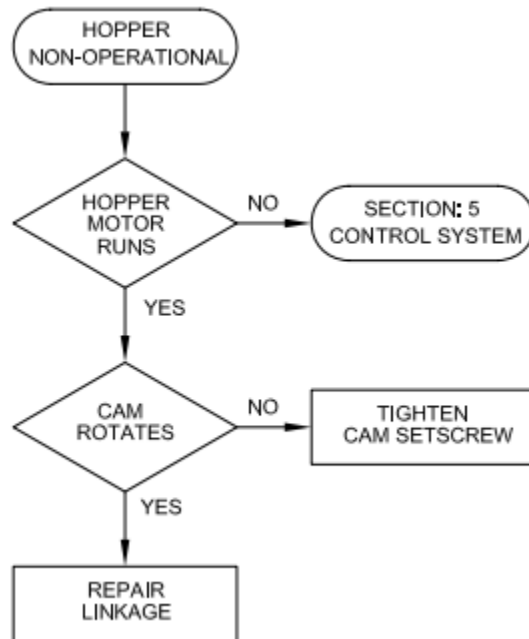

Control System

- Set the "RUN / STOP" switch to "RUN."
- If the hopper motor does not run, go to *Section 5: Control System*.

Cam Setscrew Loose

- If the cam rotates, align the cam setscrew with the flat on the hopper motor shaft and tighten the setscrew.



Agitator Linkage Damaged

- Inspect and repair the agitator linkage.

Section 2: Sphere Handling System

Feed Gates Won't Open

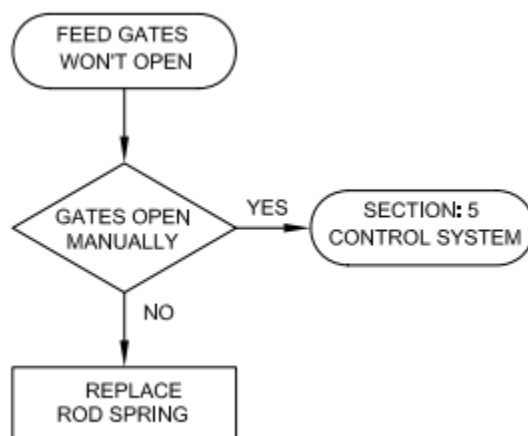

Control System

- Ensure that the drive motor is stopped.
- Remove the gate assembly.
- Use a screwdriver to lift the locking pin and unlock the feed control rod.
- If the gates open go to *Section 5: Control System*.



Feed Control Rod Spring Damaged

- Replace the feed control rod spring.

Section 2: Sphere Handling System

Drive Mechanism Non-Operational

Hand Wheel Turns

- Remove the gate assembly.
- Rotate the manual hand wheel.
- If the hand wheel does not turn, clear the jam.

Control System

- Set the “RUN / STOP” switch to “RUN.”
- Press the gate switch on the remote control to “OPEN.”
- If the “RUN” indicator on the main control panel is not flashing, go to *Section 5: Control System*.
- If the “MOTOR FAULT” indicator on the main control panel is illuminated, go to *Section 5: Control System*.

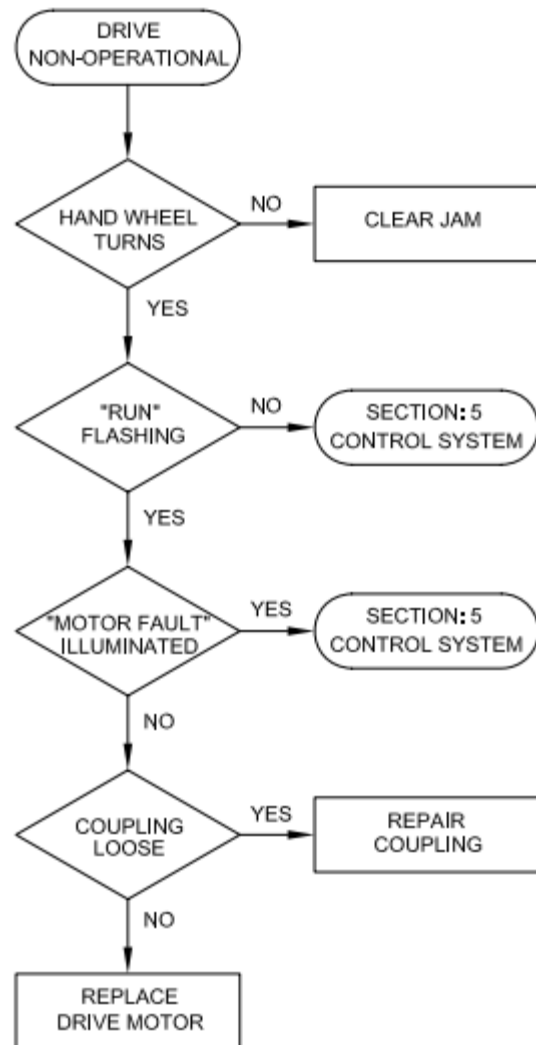

Motor Coupling

- If the coupling is turning tighten the drive shaft hub.

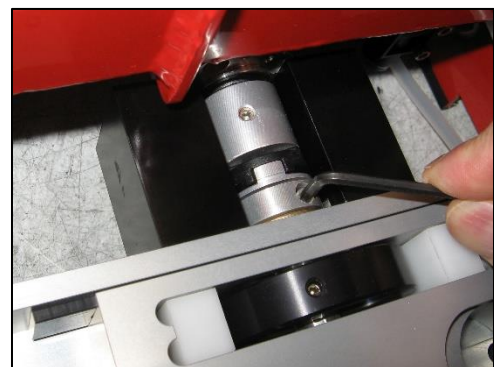

Section 2: Sphere Handling System

Feed Gates Won't Close

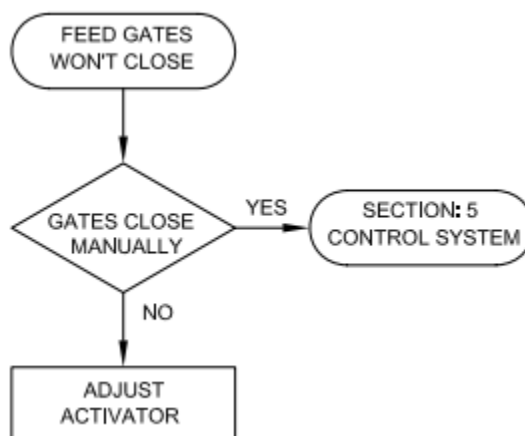

Control System

- Remove the gate assembly.
- Press on the close solenoid core to try to close the gates.
- If the gates close and lock, go to *Section 5: Control System*.



Solenoid Actuator Misaligned

- Adjust the position of the solenoid actuator.

THIS PAGE INTENTIONALLY LEFT BLANK

Section 3: Glycol System

Description

The purpose of the glycol system is to inject a fixed amount of glycol into each sphere regardless of the drop rate. The major components of the system are the glycol tank and two glycol pump assemblies. Each glycol pump assembly consists of a pump arm, constant displacement pump, inlet check valve, outlet check valve, and an injection needle.

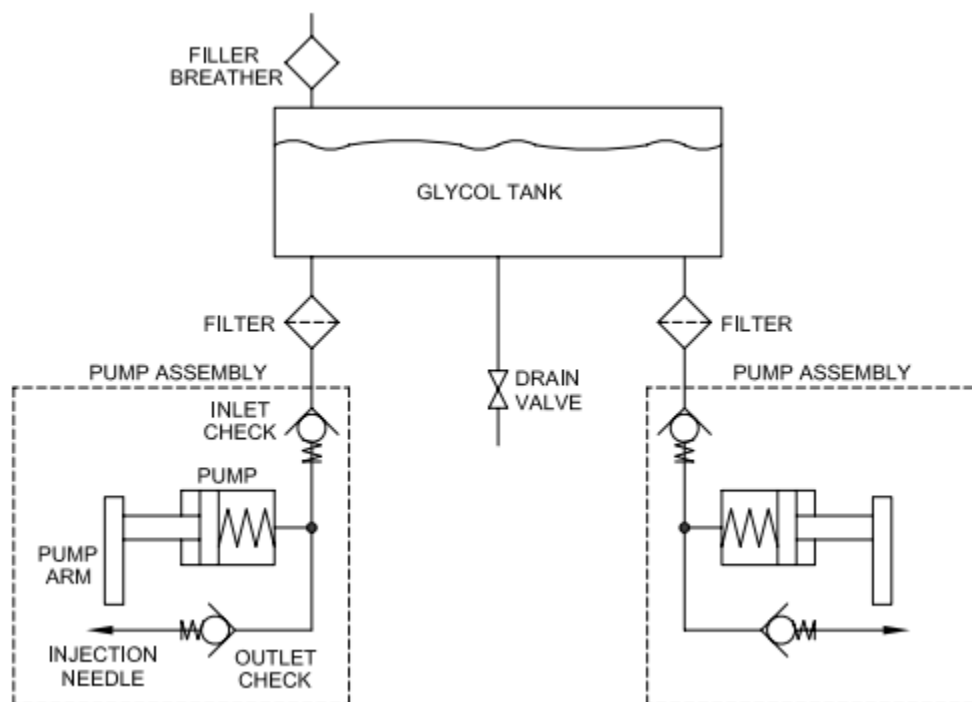

As the injection shuttle pushes a sphere towards the pump assembly, the tip of the injection needle pierces the sphere. Continued motion of the shuttle causes the sphere to press against the pump arm which compresses the piston. The inlet check valve is closed, preventing glycol from returning to the tank. As the fluid pressure in the pump cylinder rises, the outlet check valve opens, allowing the glycol in the pump cylinder to flow through the injection needle and into the sphere.

When the shuttle reverses direction, the sphere is pulled away from the pump arm, and an internal spring in the pump extends the piston. The outlet check valve is closed, preventing air from entering the cylinder through the needle. The extending piston creates a partial vacuum in the pump cylinder, and the atmospheric pressure in the glycol tank causes the inlet check valve to open, and the pump cylinder is refilled with glycol.

There are two filters in the glycol lines between the tank and the pump assemblies. They have clear outer bodies to allow visual inspection. The filters can be cleaned by removing and back flushing with water.

Glycol System Components

Glycol Tank

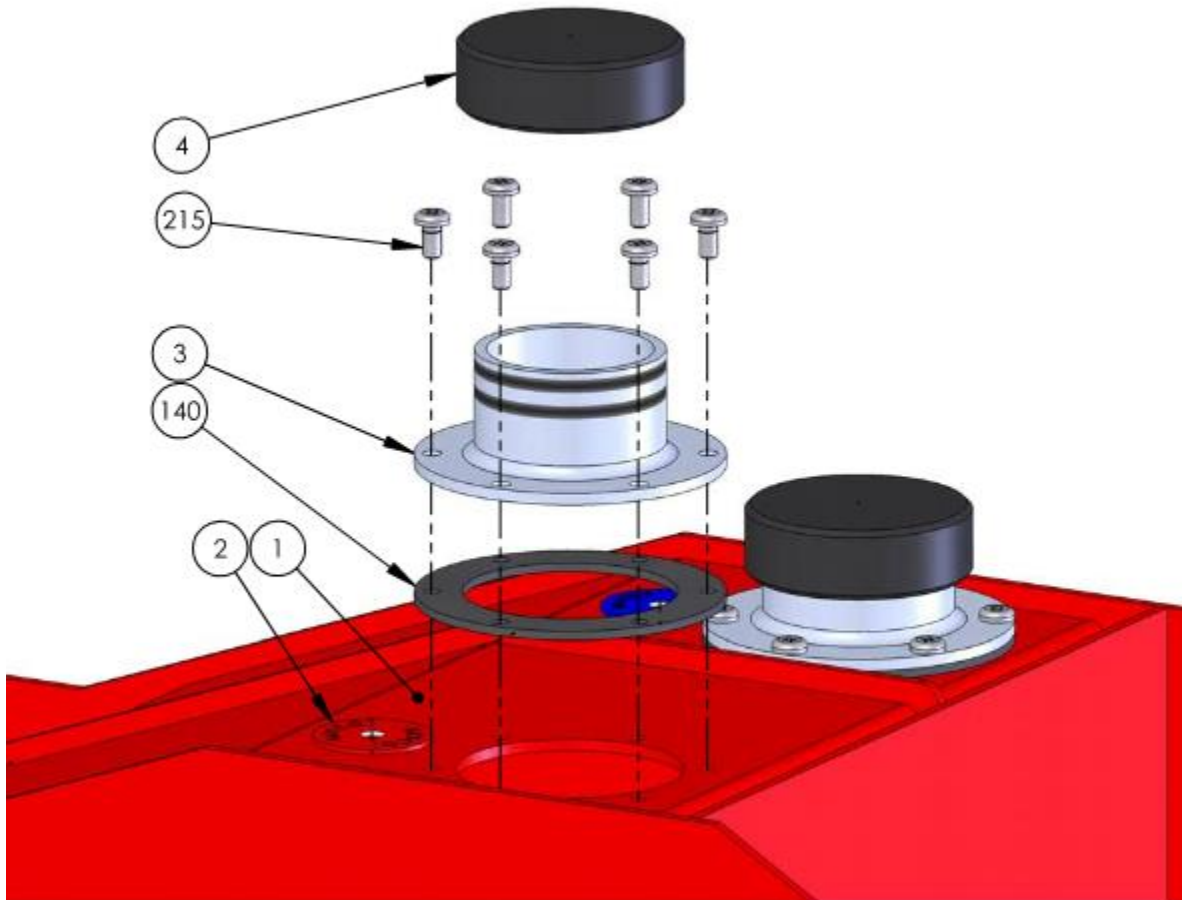

ITEM	PART #	DESCRIPTION	QTY
1	006016	TANK	1
2	005969	TAG, GLYCOL CAP	1
3	013352	FILLER NECK	1
4	013353	CAP	1
140	006398	GASKET, FILLER NECK	1
215	000546	SCREW, 10-32 x 3/8, SEAL, PNPH, SS	6

Section 3: Glycol System

Glycol Piping

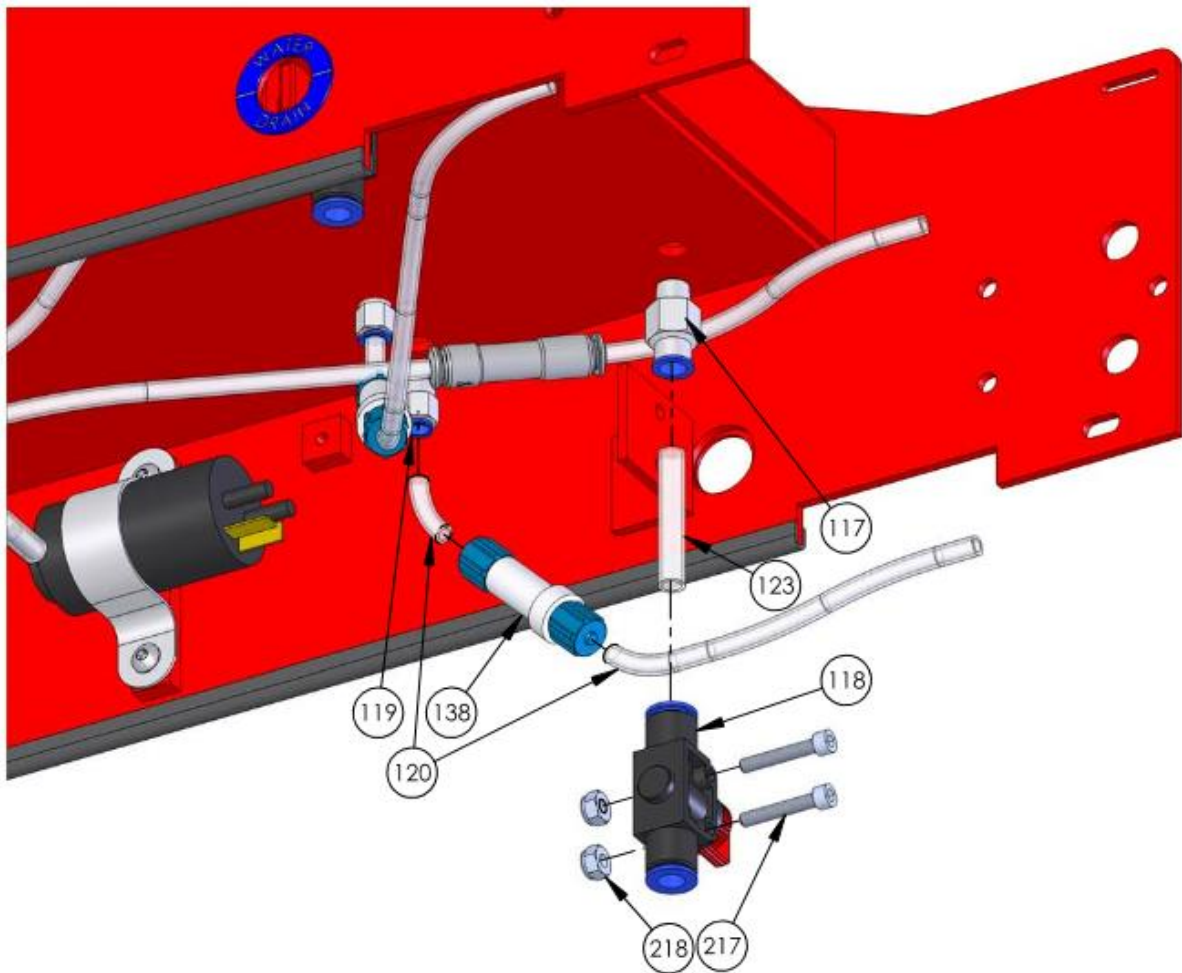

ITEM	PART #	DESCRIPTION	QTY
117	003651	ADAPTER, 1/8 NPT x 8 MM	1
118	004224	DRAIN VALVE, 8 MM	1
119	003650	ADAPTER, 1/8 NPT x 6 MM	2
120	012048	TUBING, 6 MM, CLEAR	21.25 IN
123	014817	TUBING, 8 MM, CLEAR	1.75 IN
138	006324	GLYCOL FILTER	2
217	000423	SOCKET HEAD CAPSCREW, SS, # 8-32 x 1	2
218	001659	NYLOCK NUT, SS, # 8-32	2

Section 3: Glycol System

Glycol Pump

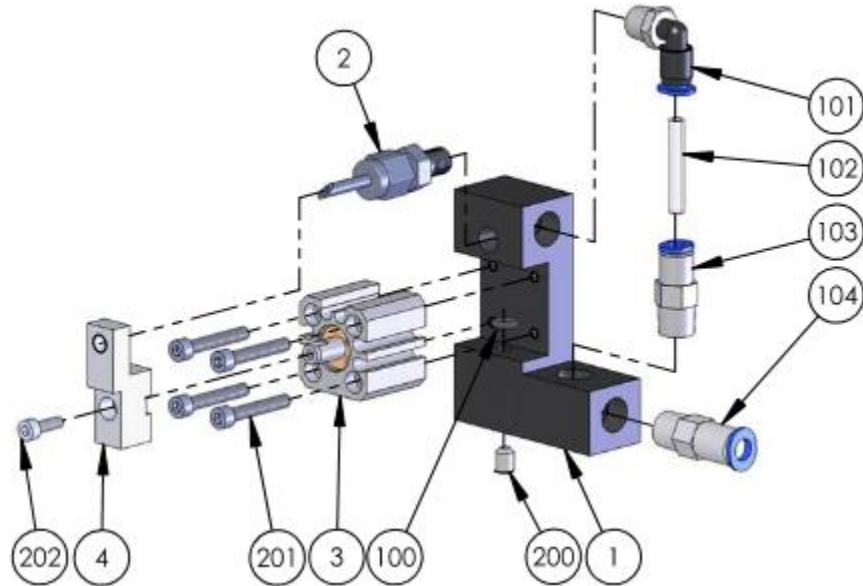

ITEM	PART #	DESCRIPTION	QTY
1	006014 / 006015	MANIFOLD BLOCK, LH / RH (LH SHOWN)	1
2	005907	INJECTION NEEDLE	1
3	005117	GLYCOL PUMP	1
4	005908	PUMP ARM	1
100	005112	O-RING, BUNA N, AS568A - 007	1
101	003643	STREET ELBOW, 1/8 NPT x 4 MM	1
102	012047	TUBING, 4 MM, CLEAR	1 IN
103	004228	OUTLET CHECK VALVE, 1/8 NPT x 4 MM	1
104	004230	INLET CHECK VALVE, 1/8 NPT x 6 MM	1
200	000525	SETSCREW, SS, # 10-32 x 1/4	1
201	000414	SOCKET HEAD CAPSCREW, SS, # 6-32 x 7/8	4
202	000328	SOCKET HEAD CAPSCREW, SS, M3.0 x 10	1

Glycol System Troubleshooting

Overview

Prior to using this troubleshooting procedure, ensure that the basic troubleshooting outlined in the operator's manual has been performed. This advanced procedure assumes that there is glycol in the tank and that the user has attempted to prime the pump without success.

To diagnose the problem, cycle the glycol pump by squeezing and releasing the pump arm. Depending on the result, use the following flowchart to determine which subsection to use.

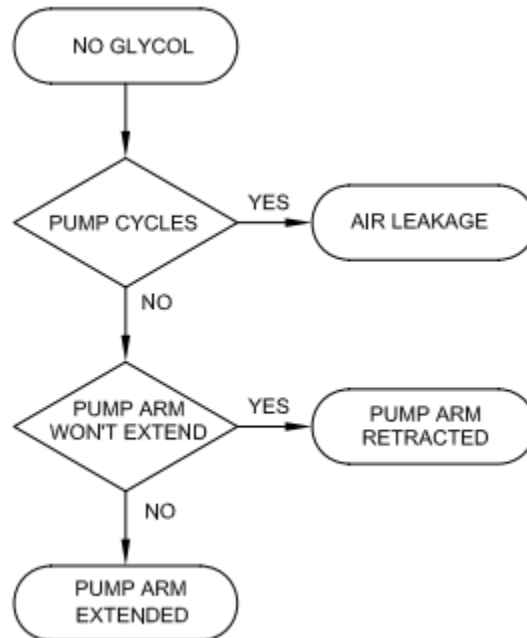

In each subsection is a secondary flowchart and detailed instructions to isolate the specific cause of the problem and determine a required action. Once the required action has been determined, the details of the repair procedure can be found in the repairs section.

Section 3: Glycol System

Air Leakage

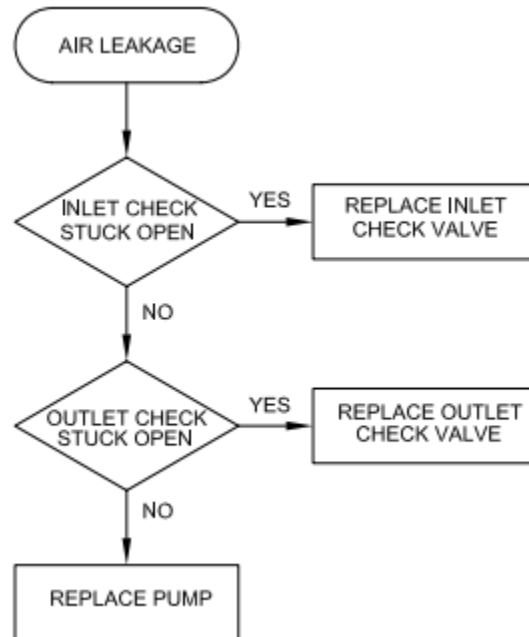

Inlet Check Valve Stuck Open

- Disconnect the glycol supply line to the inlet check valve and cap the line.
- Seal the end of the injection needle with your finger.
- Press the pump arm.
- If air or glycol flows from the inlet valve, repair or replace the inlet check valve.



Outlet Check Valve Stuck Open

- Press and hold the pump arm
- Seal the inlet check valve using your finger.
- Release the pump arm.
- If the pump arm extends, repair or replace the outlet check valve.

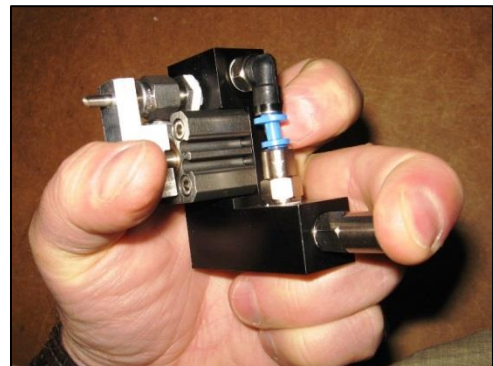

Glycol Pump Damaged

- Repair or replace the glycol pump.

Section 3: Glycol System

Pump Arm Retracted

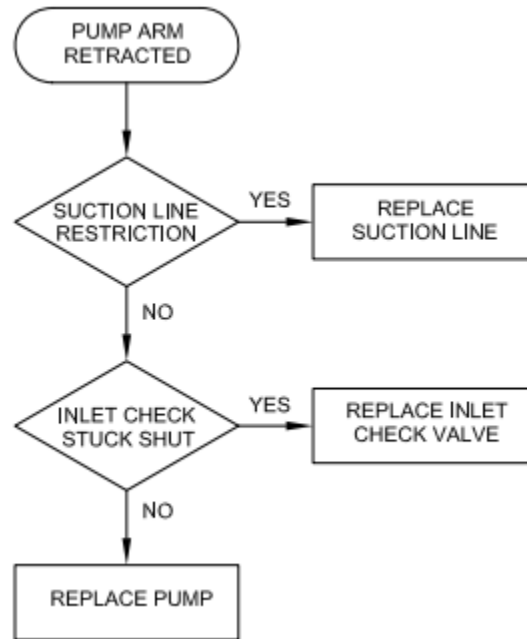

Suction Line Restriction

- Disconnect the glycol supply line to the inlet check valve.
- If the pump arm extends, repair or replace the suction line.
- Check glycol filters and clean as required.

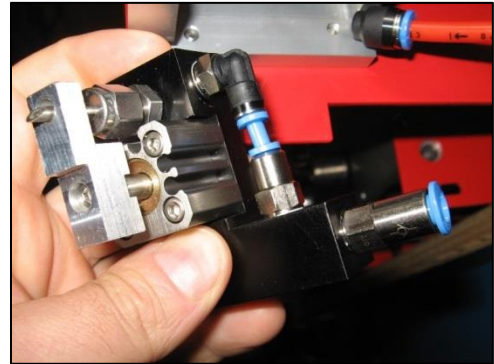

Inlet Check Valve Stuck Shut

- Remove the inlet check valve from the manifold block.
- If the pump arm extends, repair or replace the inlet check valve.



Glycol Pump Damaged

- Repair or replace the glycol pump.

Section 3: Glycol System

Pump Arm Extended

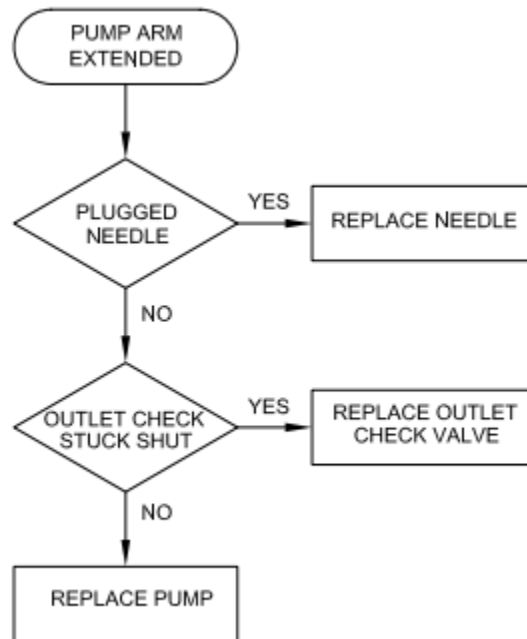

Plugged Injection Needle

- Un-thread the elbow from the manifold block.
- Remove elbow and tube from the outlet check valve.

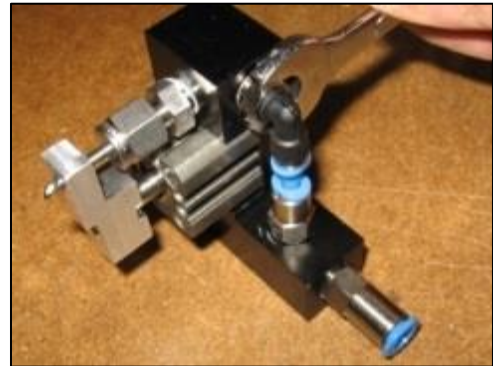

- Press the pump arm.
- If the pump arm compresses, repair or replace the injection needle.



Section 3: Glycol System

Outlet Check Valve Stuck Shut

- Un-thread the outlet check valve from the manifold block.



- Press the pump arm.
- If the pump arm compresses, repair or replace the outlet check valve.



Glycol Pump Damaged

- Repair or replace the glycol pump.

THIS PAGE INTENTIONALLY LEFT BLANK

Section 4: Water System

Description

The purpose of the water system is to spray the injection chambers with water in the event of a sphere igniting in the chamber. The major components of the system are the water tank, pump, and two nozzle assemblies. Each nozzle assembly consists of a check valve and a water nozzle mounted into a block.

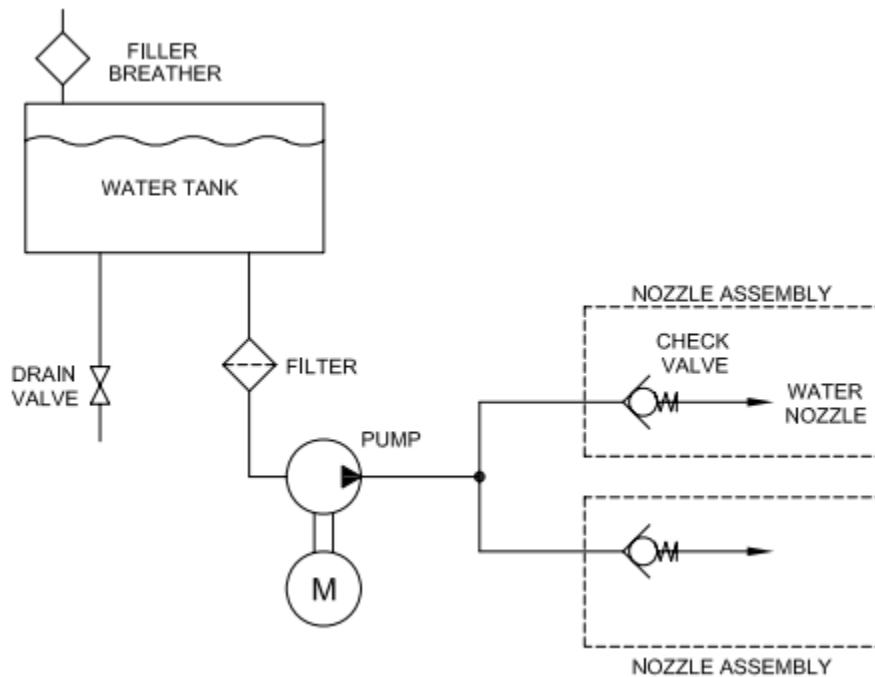

There is a filter in the water line between the tank and the pump. It has a clear outer body to allow visual inspection. The filter can be cleaned by removing and back flushing with water.

Water System Components

Water Tank

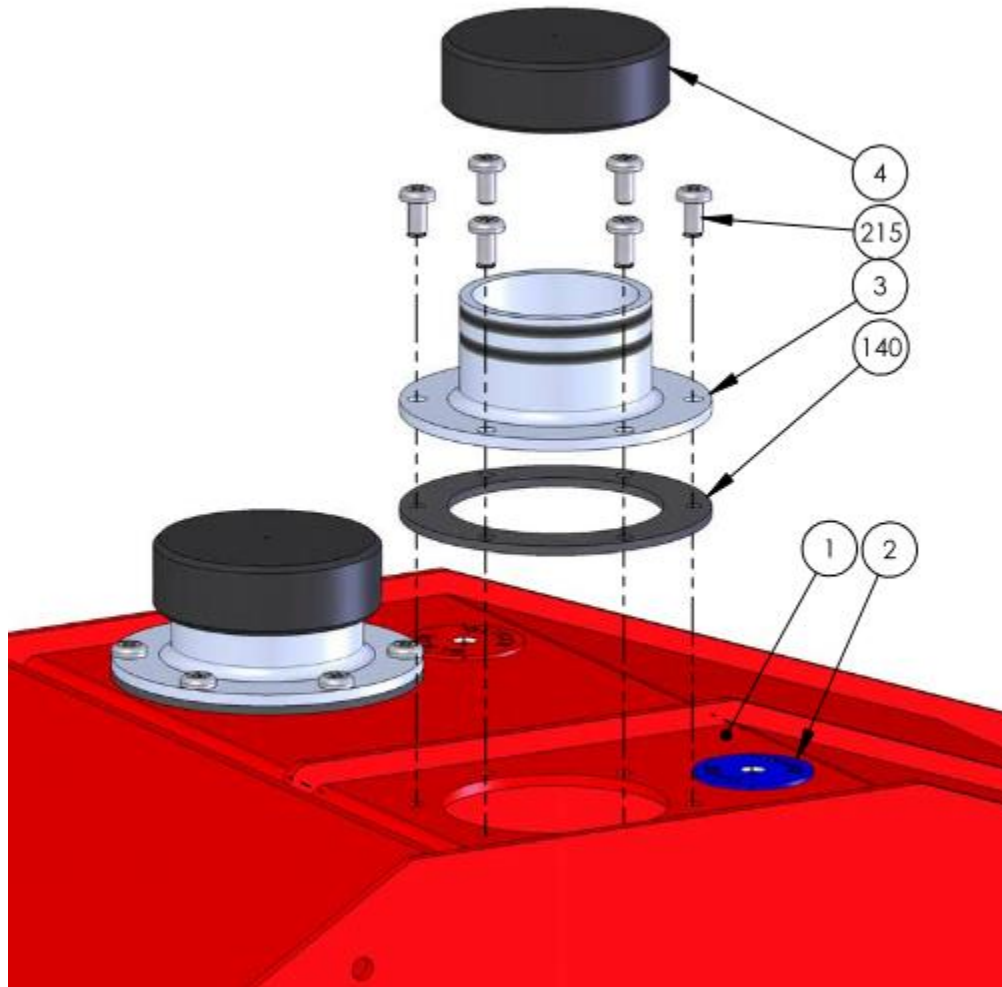

ITEM	PART #	DESCRIPTION	QTY
1	006016	TANK	1
2	005968	TAG, WATER CAP	1
3	013352	FILLER NECK	1
4	013353	CAP	1
140	006398	GASKET, FILLER NECK	1
215	000546	SCREW, 10-32 x 3/8, SEAL, PNP, SS	6

Section 4: Water System

Water Piping

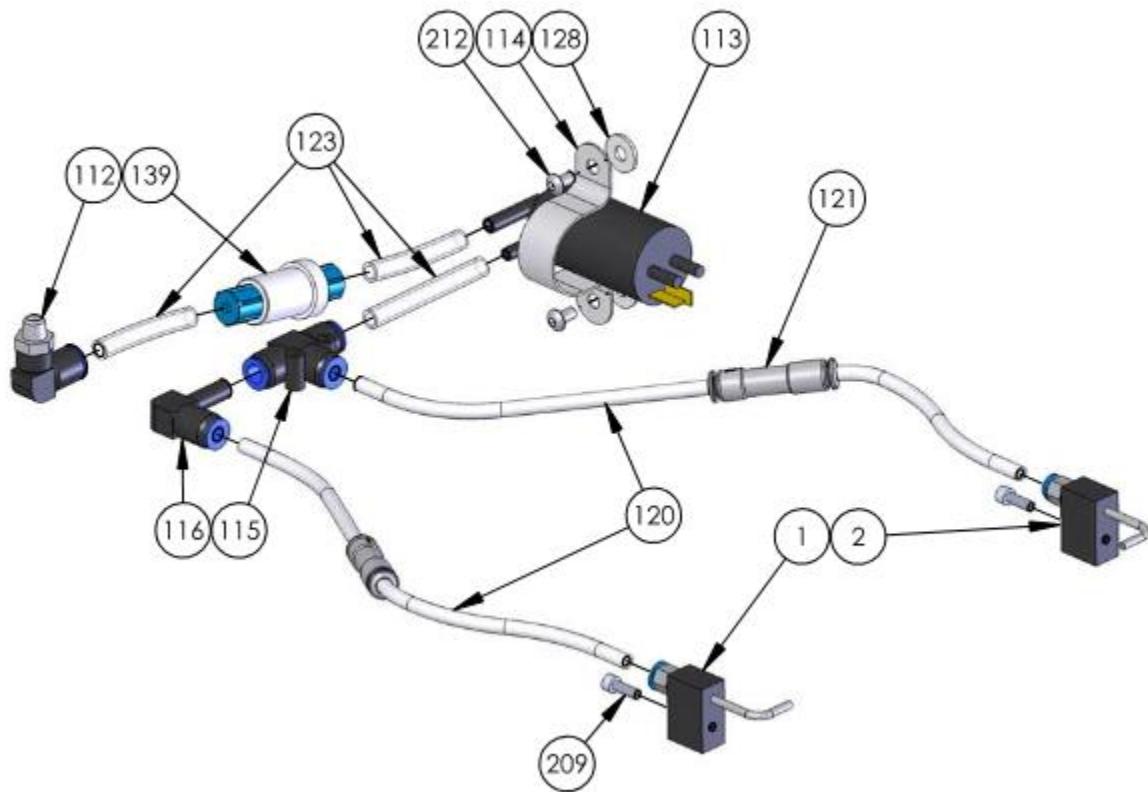

ITEM	PART #	DESCRIPTION	QTY
1	005902	NOZZLE ASSY, LH	1
2	005904	NOZZLE ASSY, RH	1
112	003649	STREET ELBOW, 1/8 NPT x 8 MM	1
113	006003	WATER PUMP	1
114	002982	PUMP BRACKET	1
115	003660	TEE, 8 MM x 8 MM x 6 MM	1
116	003648	STREET ELBOW, 8 MM x 6 MM	1
120	012048	TUBING, 6 MM, CLEAR	24 IN
121	017831	CHECK VALVE	2
123	014817	TUBING, 8 MM, CLEAR	10 IN
128	005138	FLAT WASHER	2
139	006236	WATER FILTER	1
209	000419	SOCKET HEAD CAPSCREW, SS, # 8-32 X 1/2	2
212	000513	BUTTON HEAD CAPSCREW, SS, #10-24 x 3/8	2

Section 4: Water System

Water Drain Valve

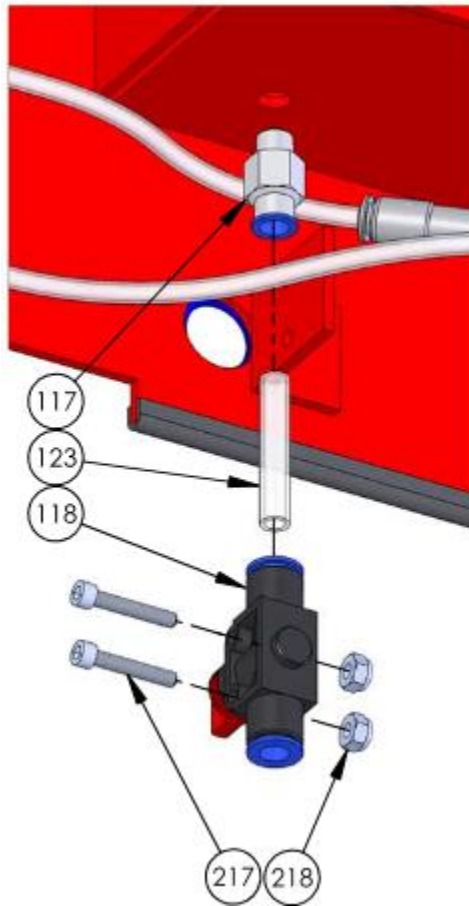

ITEM	PART #	DESCRIPTION	QTY
117	003651	ADAPTER, 1/8 NPT x 8 MM	1
118	004224	DRAIN VALVE, 8 MM	1
123	014817	TUBING, 8 MM, CLEAR	1.75 IN
217	000423	SOCKET HEAD CAPSCREW, SS, #8-32 x 1	2
218	001659	NYLOCK NUT, SS, #8-32	2

Water System Troubleshooting

Overview

Prior to using this troubleshooting procedure, ensure that the basic troubleshooting outlined in the operator's manual has been performed. This advanced procedure assumes that there is water in the tank.

Use the following flowchart and detailed instructions to isolate the specific cause of the problem and determine a required action. Once the required action has been determined, the details of the repair procedure can be found in the repairs section.

No Water

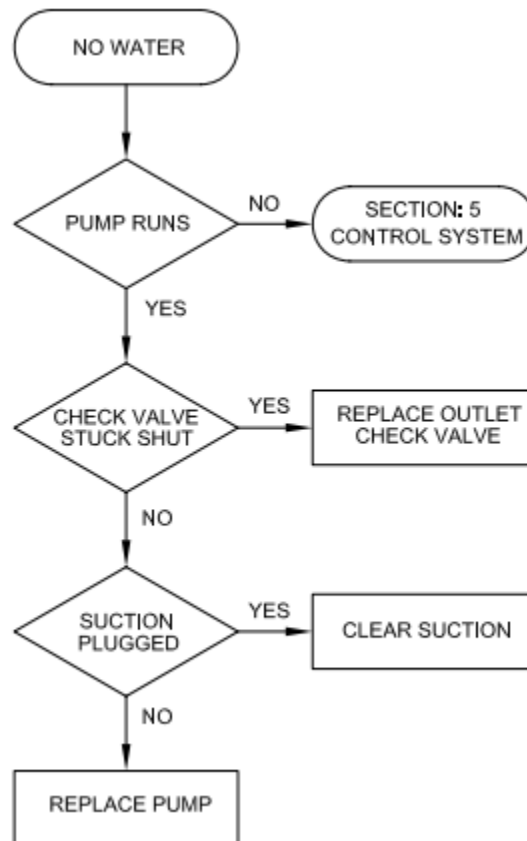

Section 4: Water System

Control System

- Switch the water pump to the “ON” position momentarily.
- If the water pump does not run, see *Section 5: Control System*.

Check Valve Stuck Shut

- Disconnect one water discharge line from its nozzle check valve.
- Switch the water pump to the “ON” position momentarily.
- If no water flows from the discharge line, replace the check valve.
- Repeat procedure for other check valve.



Suction Plugged

- Disconnect the pump suction line from the elbow in the bottom of the tank.
- If no water flows from the elbow, clean the tank suction.
- Check water filter and clean as required.



Water Pump Damaged

- Repair or replace the water pump.

Section 5: Control System

Control System Operation

The control system for the Red Dragon is microprocessor based. Unlike conventional systems which have switches hard wired to specific devices, a microprocessor system has switches and sensors which provide input signals to a microprocessor. Based on these inputs, a software program makes decisions and sends signals to various output devices such as motors, solenoids, and indicators.

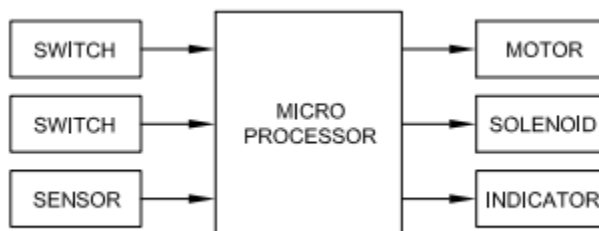

The advantage of this type of system is that it allows complex operation of the output devices. Any switch or sensor can be made to operate any output device based on the software program. It also allows the introduction of timing into the system. There can be delays and sequencing of output devices to make the dispenser function better. The details of the software program and system operation is quite complex and beyond the scope of this manual. However, the following sub sections explain the basic operation and interaction of the control system components.

Level Switch Operation

The water level switch is a float type switch located in the water tank. When the water level is low, the switch is open. The microprocessor illuminates the “LOW WATER” indicator, and flashes the “FAULT” indicator on the remote control. When the water level reaches the minimum required level, the switch closes, and the microprocessor extinguishes the “LOW WATER” and “FAULT” indicators. If the water level is low, the microprocessor ignores the input signal from the “RUN / STOP” switch.

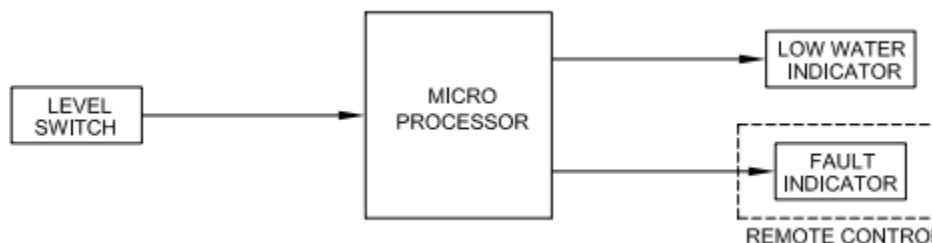

This acts as an interlock to prevent operation of the dispenser when there is insufficient water in the reservoir. A faulty connection or broken wire will also produce an open circuit, preventing operation of the dispenser.

Section5: Control System

Hopper Operation

The hopper agitator is driven by a DC motor. When the “RUN / STOP” switch is set to the “RUN” position, the microprocessor checks the level switch to see if there is enough water to operate the dispenser. If the water level is adequate, a 24V signal is sent to the hopper motor. The microprocessor also illuminates the “RUN” indicators on the main control panel and on the remote control.

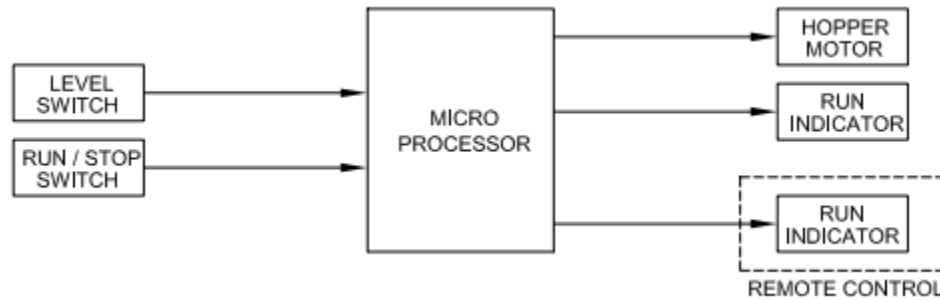

Gate Operation

The remote control provides the input signals to operate the feed gate solenoids. The open and close solenoids are used to change the position of the feed control rod and the feed gates.

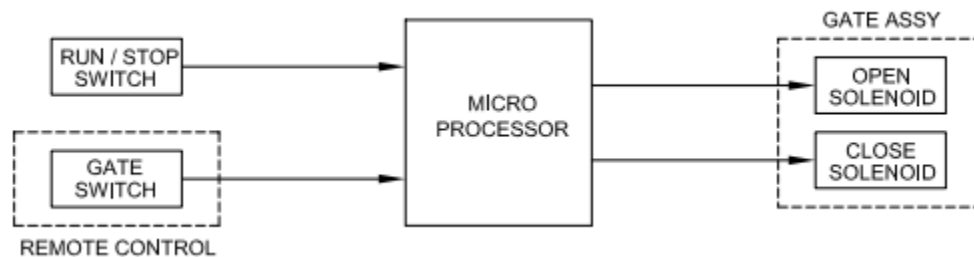

When the “RUN / STOP” switch is in the “STOP” position, the inputs from the remote control are ignored. When it is switched to the “RUN” position, there is also a short delay before the remote control signals are acted upon. This is to ensure that the hopper has time to fill its outlet queues before the gates open.

When the gate switch is pressed to the “OPEN” position, a signal is sent to energize the close solenoid. The close solenoid extends, pushing the feed control rod and takes the lateral pressure off the open solenoid pin. While the close solenoid holds the feed control rod in this position, a signal is sent to the open solenoid to retract the locking pin.

While the locking pin is retracted by the open solenoid, the close solenoid is de-energized, allowing the feed control rod to be driven open by the feed control spring. Finally the open solenoid is de-energized.

Section5: Control System

When the gate switch is pressed to the “CLOSE” position, a signal is sent to energize the close solenoid. The close solenoid extends, pushing the feed control rod and compressing the feed control spring. When the groove in the feed control rod aligns with the open solenoid locking pin, the spring loaded pin enters the groove and locks the gate shut. After a time delay, the close solenoid de-energizes.

Drive Motor Operation

The remote control also provides the input signals to operate the drive motor

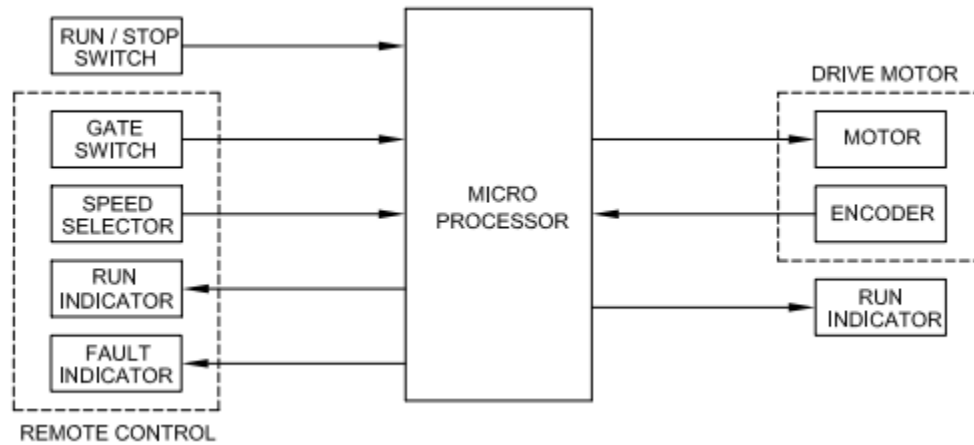

When the “RUN / STOP” switch is in the “STOP” position, the inputs from the remote control are ignored and the drive motor will not run. When the gate switch is pressed to the “OPEN” position, a signal is sent to the gate solenoids to open the feed gates. After a short delay, a signal is then sent to turn on the drive motor.

This delay is to ensure that the first spheres have fallen cleanly into the injection shuttle before attempting to move the shuttle. The microprocessor also causes the “RUN” indicators on the main control panel and on the remote control to flash.

The motor speed is selected by a three bit, rotary encoder located on the remote control. Using only three signal wires, it sends a speed signal from one to seven which is decoded by the microprocessor to determine the desired motor speed. The drive motor is a DC motor operating on a closed loop control system.

When the microprocessor sends a power signal to the motor, the motor shaft rotates. On the rear of the motor is an encoder which measures the actual speed of the motor shaft and reports this back to the microprocessor.

The microprocessor compares the actual speed with the speed requested by the remote control and makes adjustments to the motor signal until the actual speed matches the requested speed. This adjustment process takes place continuously when the drive motor is running to ensure that it is at the correct speed. The motor signal is varied using a technique called pulse width modulation (PWM).

Section5: Control System

When the operator selects a faster speed, there will be a momentary imbalance between the desired speed and actual speed. The microprocessor sends an increased signal to the motor to cause it to speed up. The motor signal increases gradually over a fraction of a second so that the motor speed increases smoothly.

If the dispenser jams, the motor will stop turning and there will be a large difference between the desired speed and the actual speed. Initially, the microprocessor tries to increase the motor power to eliminate this error. However, if the speed error persists for more than a fixed amount of time, the microprocessor decides that the machine is jammed. The motor first reverses at a slow speed for a fixed time period and then resumes normal operation. During this operation, the “FAULT” indicator on the remote control will flash.

When the gate switch is pressed to the “CLOSE” position, the drive motor continues to run for three more revolutions to purge the remaining spheres in the injection head. To prevent the motor from acting like a generator when the manual hand wheel is turned, there is a motor isolation relay. When there is no power to the dispenser, the relay contacts are open, and the drive motor is isolated from the main control board. When power is supplied to the dispenser, the relay contacts close and connect the drive motor to the main control board.

Water Pump Operation

When the “WATER” switch is pressed, a 24VDC signal is sent operate the water pump. The microprocessor illuminates the “WATER” indicator on the main control panel. The microprocessor also sends a signal to the close solenoid to close the feed gates.

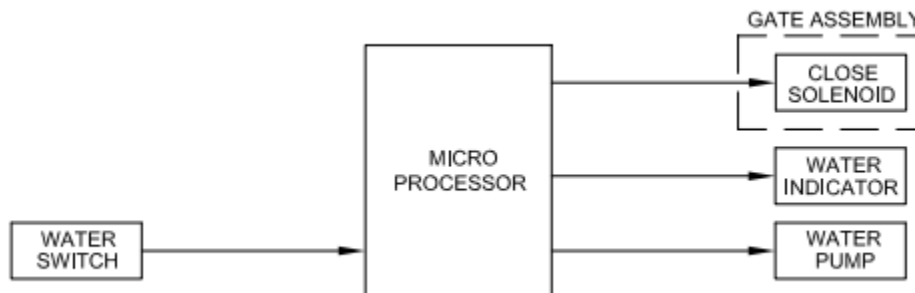

The dispenser is also equipped with a rechargeable battery. A built in charger system maintains charge on the battery whenever the unit is receiving power from an external power supply. When there is no external power supply, pressing the “WATER” switch connects the 12VDC emergency battery directly to the emergency water pump.

Section5: Control System

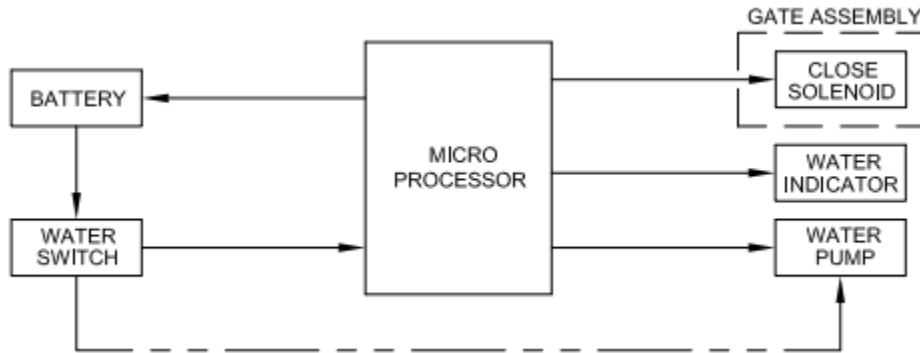

Sphere Counting

When the gate switch is pressed to the “OPEN” position, the microprocessor begins counting spheres based on motor revolutions. The count is displayed on the segmented LED display. When the gate switch is pressed to the “CLOSE” position, it stops counting spheres.

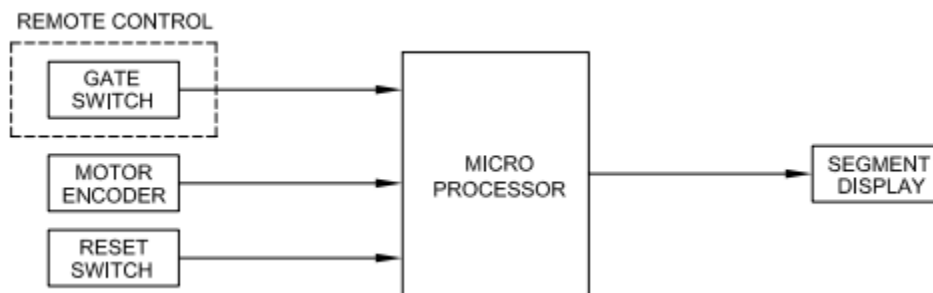

By pressing and holding the “COUNT RESET” switch, the sphere count can be reset to zero. By pressing the switch momentarily, the display can be toggled between normal display and a lifetime count of spheres indicated in thousands

Section5: Control System

Main Control Board Layout

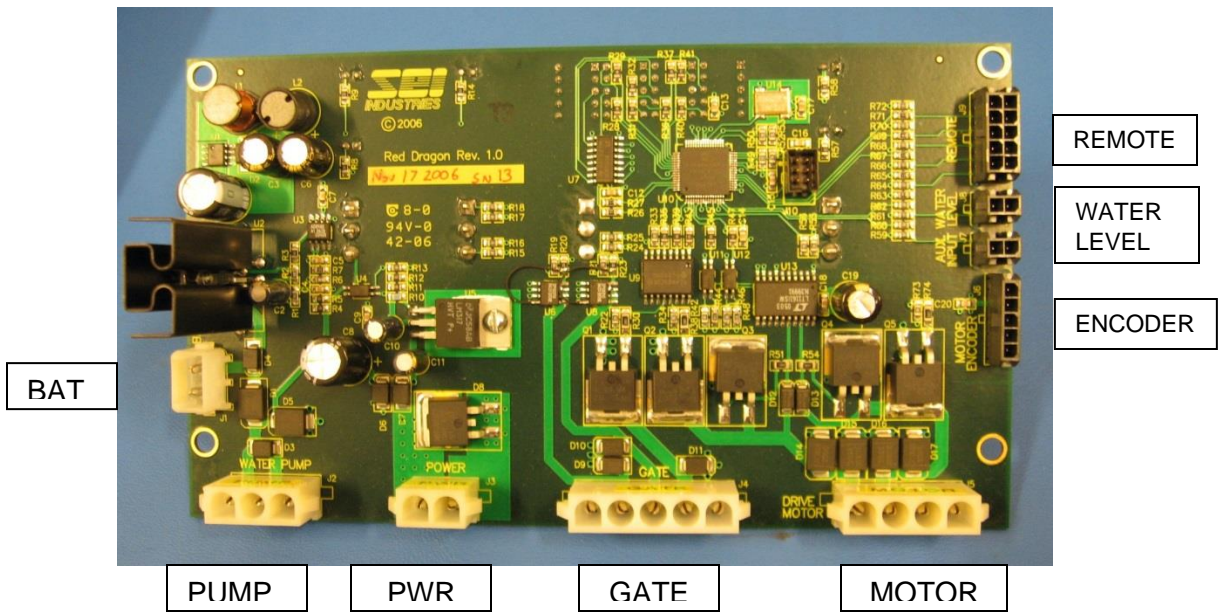

Section5: Control System

Wiring Diagrams (continued)

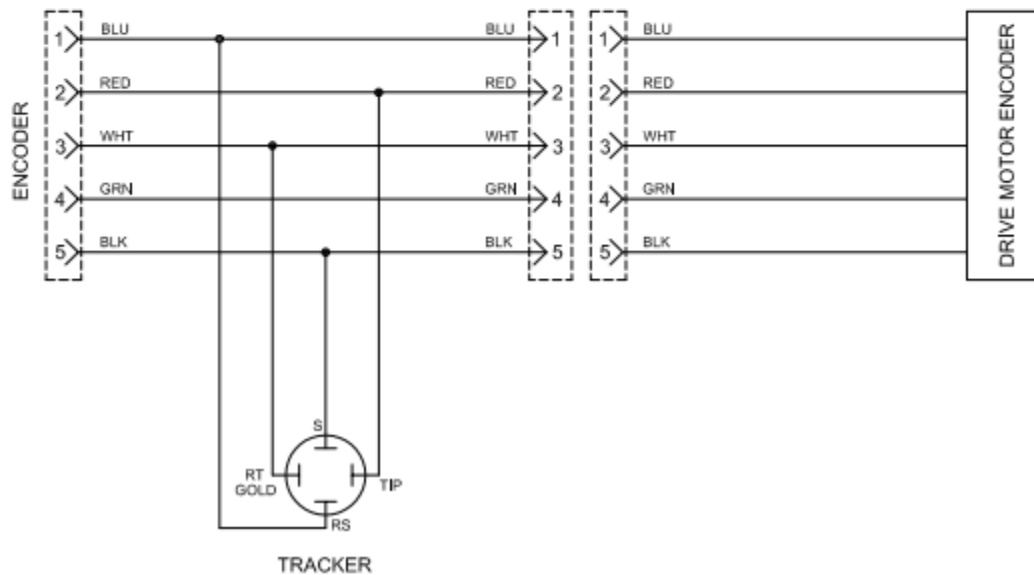
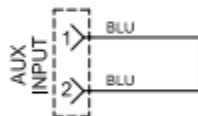
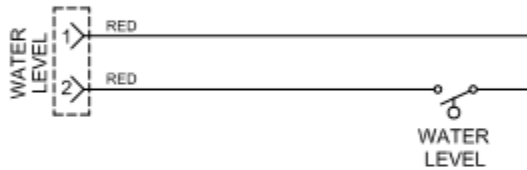
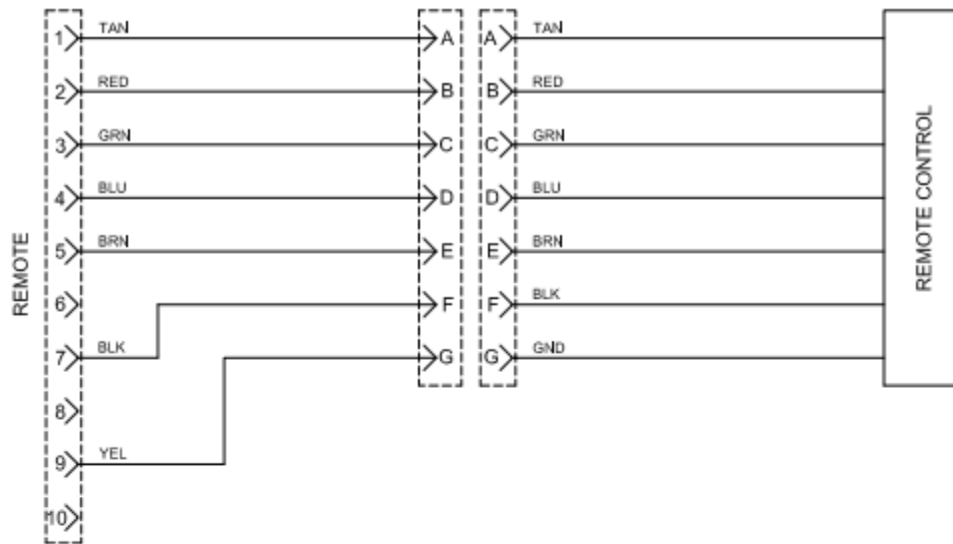

Control System Components

Main Control Panel

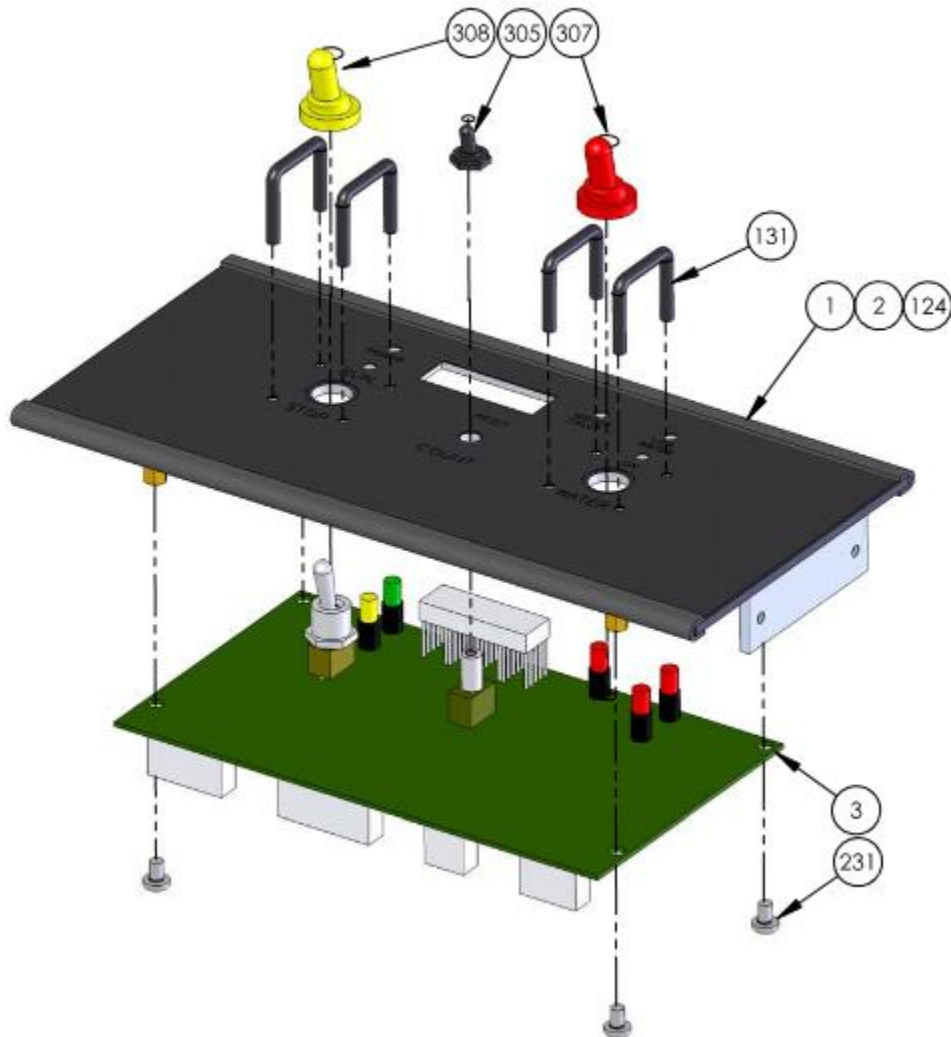

ITEM	PART #	DESCRIPTION	QTY
1	005958	CONTROL PANEL	1
2	005960	CONTROL PANEL OVERLAY	1
3	005961	MAIN CONTROL BOARD	1
124	003128	U CHANNEL, 1/8 X 1/4	2
131	005139	SWITCH GUARD, 1 X 1 X # 4-40	4
231	000486	MACHINE SCREW, PAN PHILLIPS, SS, # 8-32 X 1/4	4
305	001364	SWITCH BOOT, 1/4-40, BLACK	1
307	001366	SWITCH BOOT, M12, RED	1
308	001367	SWITCH BOOT, M12, YELLOW	1

Section5: Control System

Remote Control

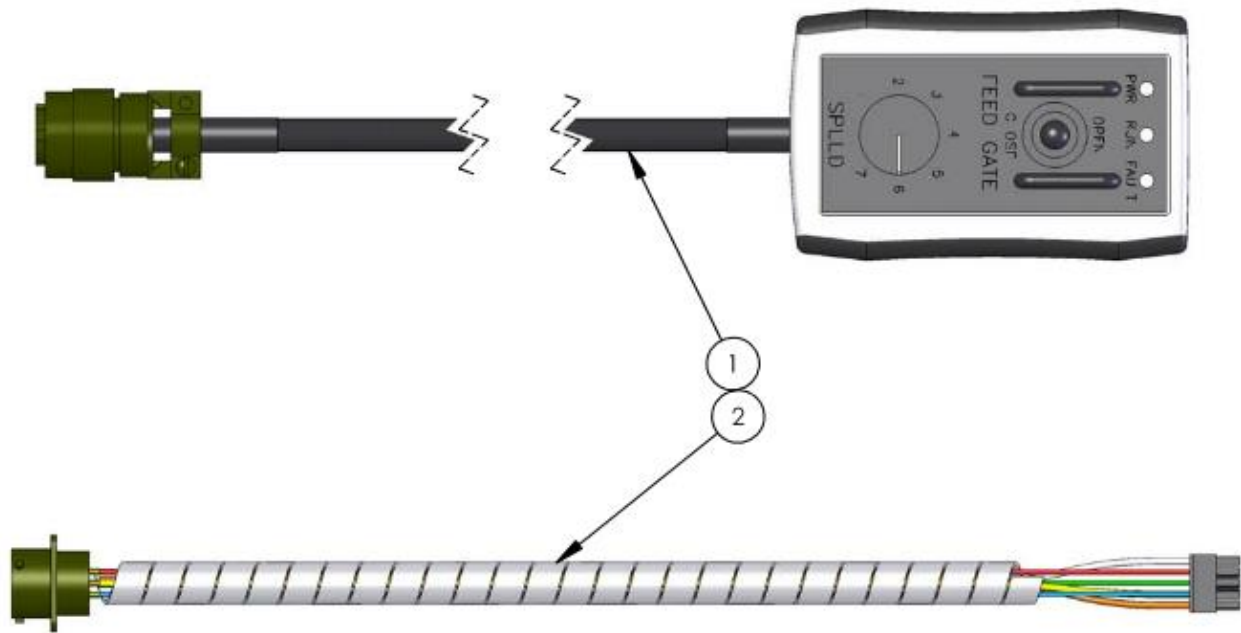

ITEM	PART #	DESCRIPTION	QTY
1	005962	REMOTE CONTROL	1
2	005973	REMOTE CONTROL WIRING HARNESS	1

Section5: Control System

Power Wiring

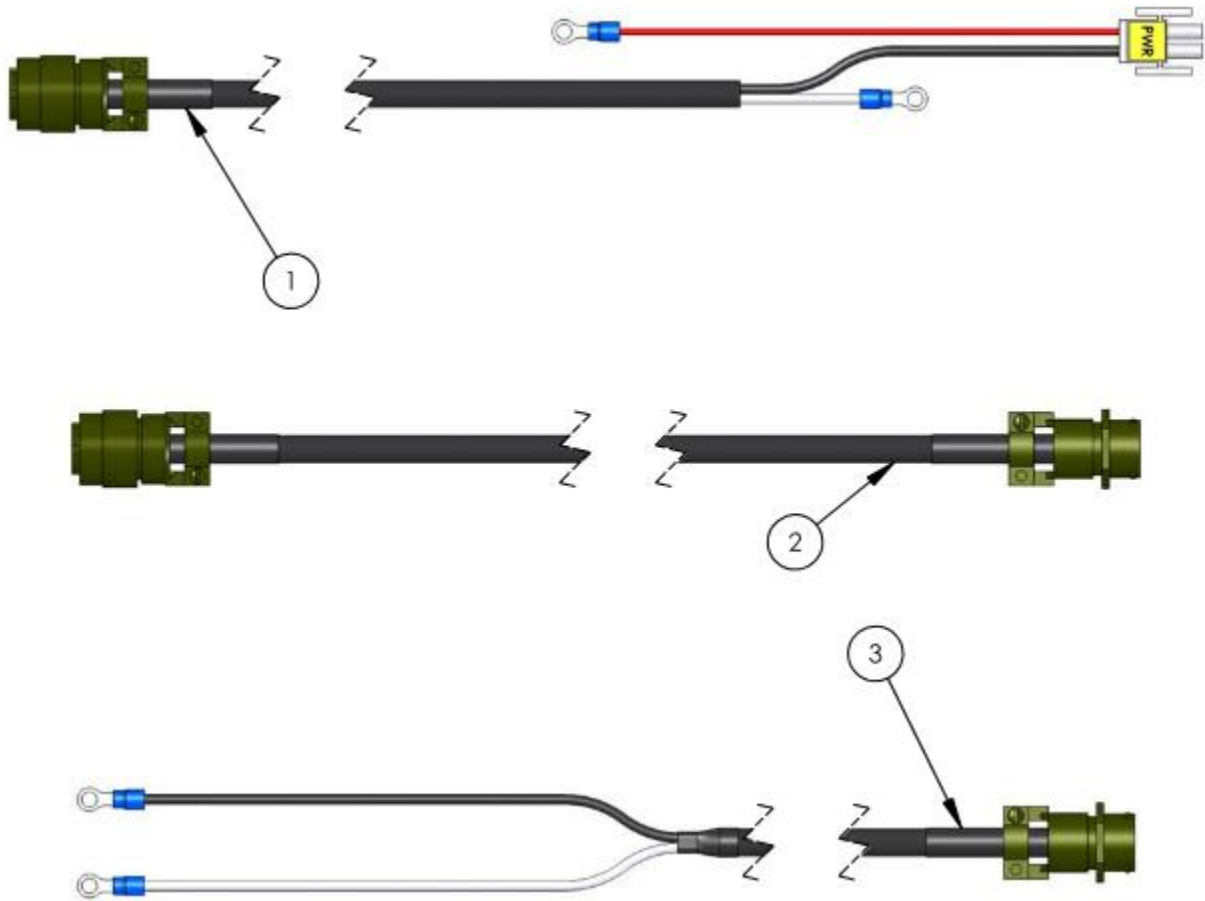

ITEM	PART #	DESCRIPTION	QTY
1	005967	POWER WIRING HARNESS	1
2	005975	POWER CORD, MS3116F-12-3P	1
3	005976	POWER CORD, AUXILIARY	1
300	000900	CIRCUIT BREAKER, MS3320, 5A	1

Section5: Control System

Wiring Harness

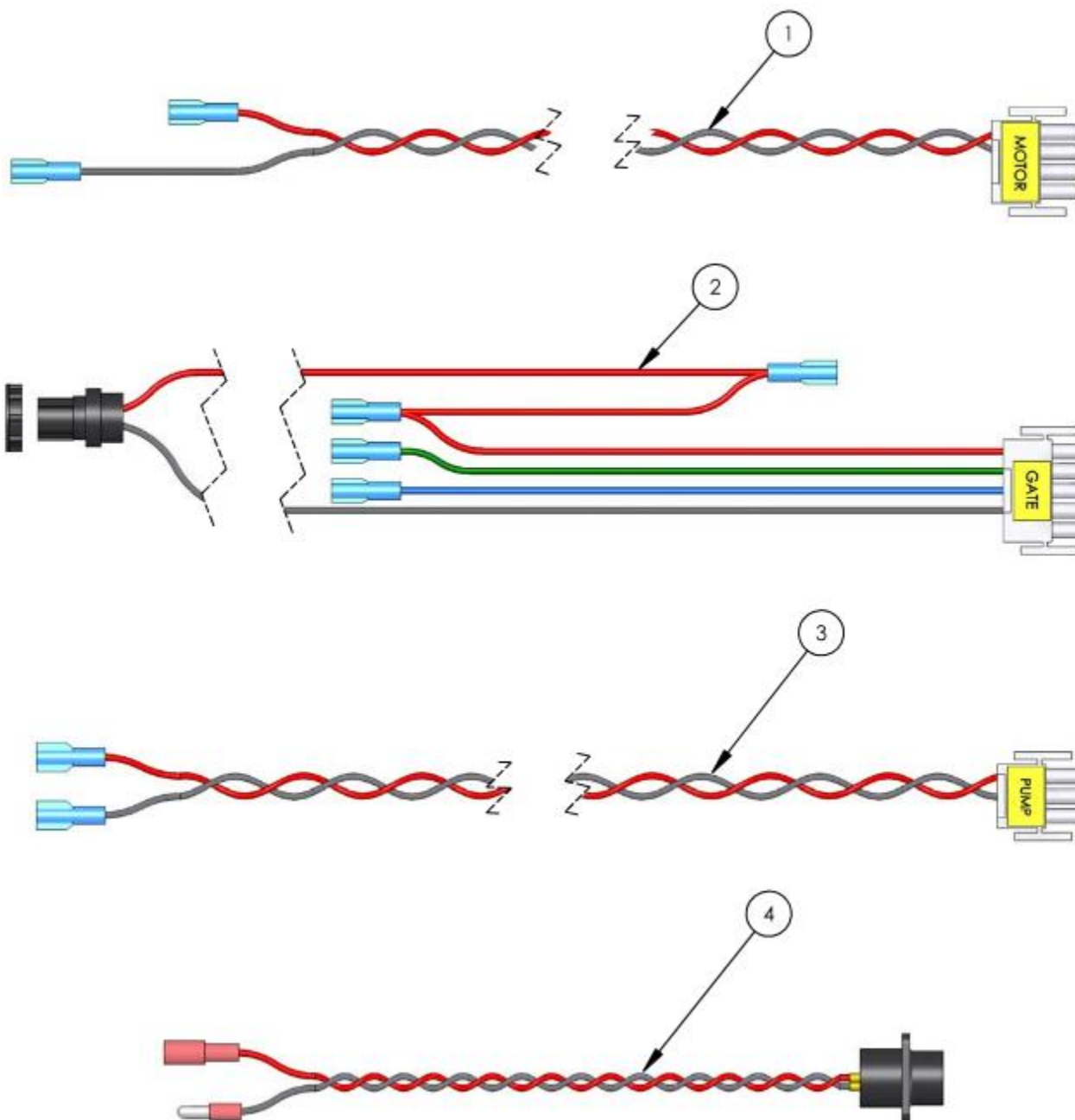

ITEM	PART #	DESCRIPTION	QTY
1	005903	DRIVE MOTOR WIRING HARNESS	1
2	005916	GATE WIRING HARNESS	1
3	005931	PUMP WIRING HARNESS	1
4	005949	HOPPER MOTOR WIRING HARNESS	1

Section5: Control System

Water Level Switch

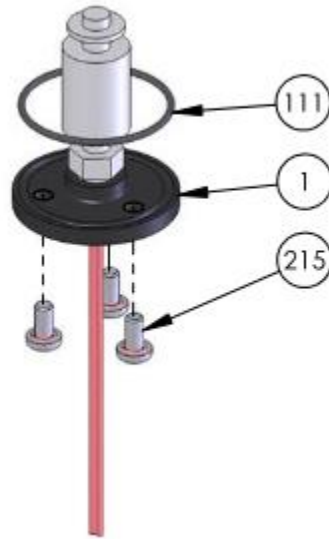

ITEM	PART #	DESCRIPTION	QTY
1	005931	LEVEL SWITCH ASSY	1
111	005993	O-RING, BUNA N, AS568A - 029	1
215	000546	SEAL BOLT, SS, #10-32 X 3/8	3

Control System Troubleshooting

No Power

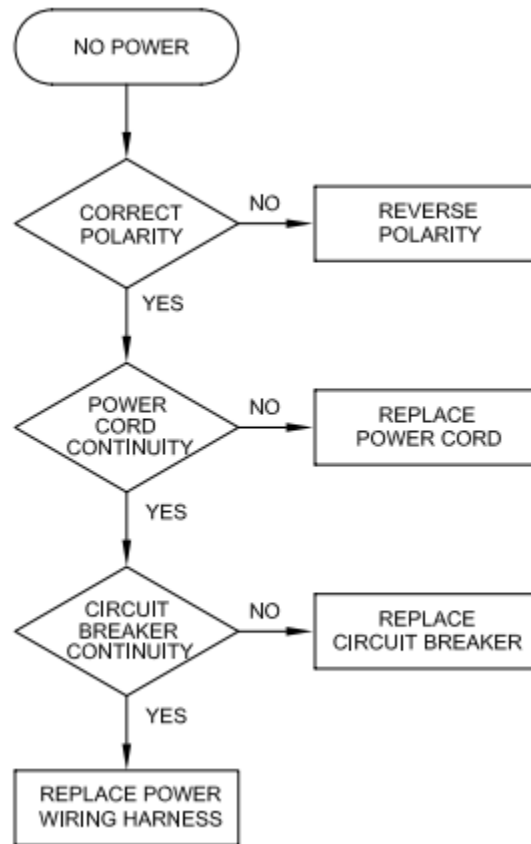

Power Supply Polarity

- Disconnect the power cord from the pigtail cord on the front of the dispenser.



Section5: Control System

- Place the positive probe of a voltmeter into socket “A” of the power cord receptacle.
- Place the negative probe into socket “B” of the power cord receptacle.
- Measure the supply voltage. If the voltage measurement is negative, reverse the polarity of the power supply.

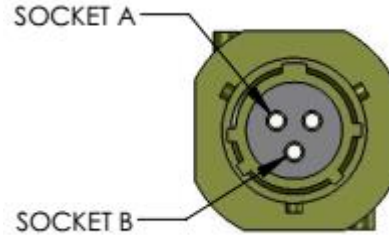

Power Cord Damaged

- Disconnect the power cord from the external power supply.
- Check continuity between pin “A” and socket “A” on the power cord. If there is no continuity, replace the main power cord.
- Check continuity between pin “B” and socket “B” on the power cord. If there is no continuity, replace the main power cord.

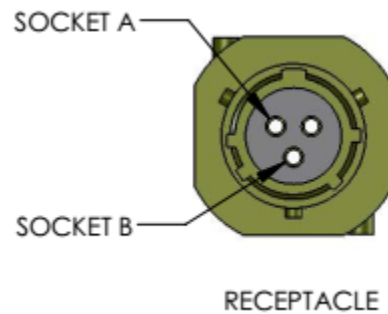
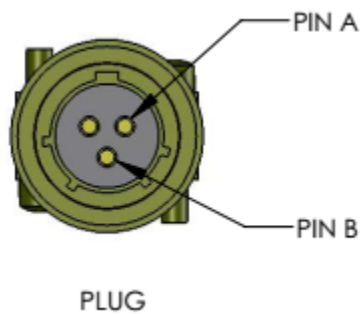

Circuit Breaker Damaged

- Remove the four #10-24 x 3/8 button head capscrews which secure the control panel to the tank assembly.
- Tilt the control panel forwards to access the main circuit breaker.
- Remove the emergency battery.



Section5: Control System

- Check that the main circuit breaker is pushed in.
- Check the continuity across the two terminals of the main circuit breaker.
- If there is no continuity, replace the main circuit breaker.



Power Wiring Harness Damaged

- Replace the power wiring harness.

Section5: Control System

Main Circuit Breaker Trips

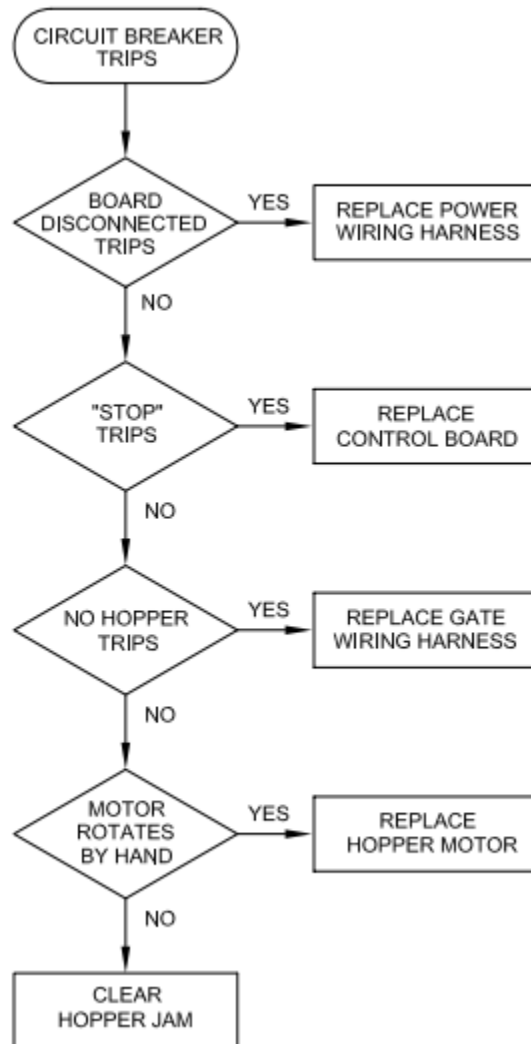

Section5: Control System

Power Wiring Harness Damaged

- Remove the four # 10-24 x 3/8 button head capscrews which secure the control panel to the tank assembly.
- Tilt the control panel forwards to access the main control board.
- Disconnect the power wiring harness from the main control board.
- Reset the breaker.
- If the breaker trips replace the power wiring harness.



Main Control Board Damaged

- Switch the “RUN / STOP” switch to the “STOP” position.
- Reconnect the “PWR” wiring harness to the main control board.
- If the breaker trips, replace the main control board.

Gate Wiring Harness Damaged

- Remove the hopper from the gate assembly.
- Switch the “RUN / STOP” switch to the “RUN” position.
- If the breaker trips replace the gate wiring harness.

Hopper Motor Damaged

- Rotate the agitator cam and hopper motor by hand.
- If the motor rotates, replace the hopper motor.



Hopper Jammed

- Clear the jam in the hopper agitator.

Section5: Control System

Low Water Interlock Not Functioning

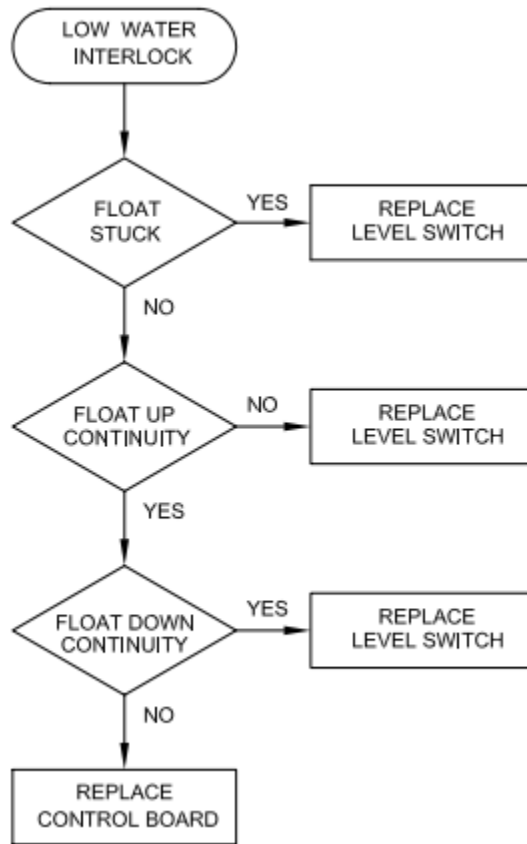

Level Switch Damaged

- Disconnect the power cord from any external power source.
- Drain the water tank.
- Drain the glycol tank.
- Remove # 10-32 x 3/8 button head capscrew that secures the P-clip to the tank.
- Unwrap approximately 4" of spiral wrap from the wires.



Section5: Control System

- Remove the three # 10-32 x 3/8 seal screws that secure the level switch into the tank.



- Remove the level switch and O-ring from the tank.
- Check the level switch float for freedom of motion.
- If float is stuck, replace the level switch



- Remove the four #10-24 x 3/8 button head capscrews which secure the control panel to the tank assembly.
- Tilt the control panel forwards to access the main control board.



- Unplug the level switch from the main control board.
- Check continuity across the two pins of the float switch plug when the float is at the top of the stem.
- If there is no continuity, replace the level switch



Section5: Control System

- Check continuity across the two pins of the float switch plug when the float is at the bottom of the stem.
- If there is continuity, replace the level switch.



Control Board Damaged

- Replace the main control board.

Section5: Control System

Hopper Agitator Non-Operational

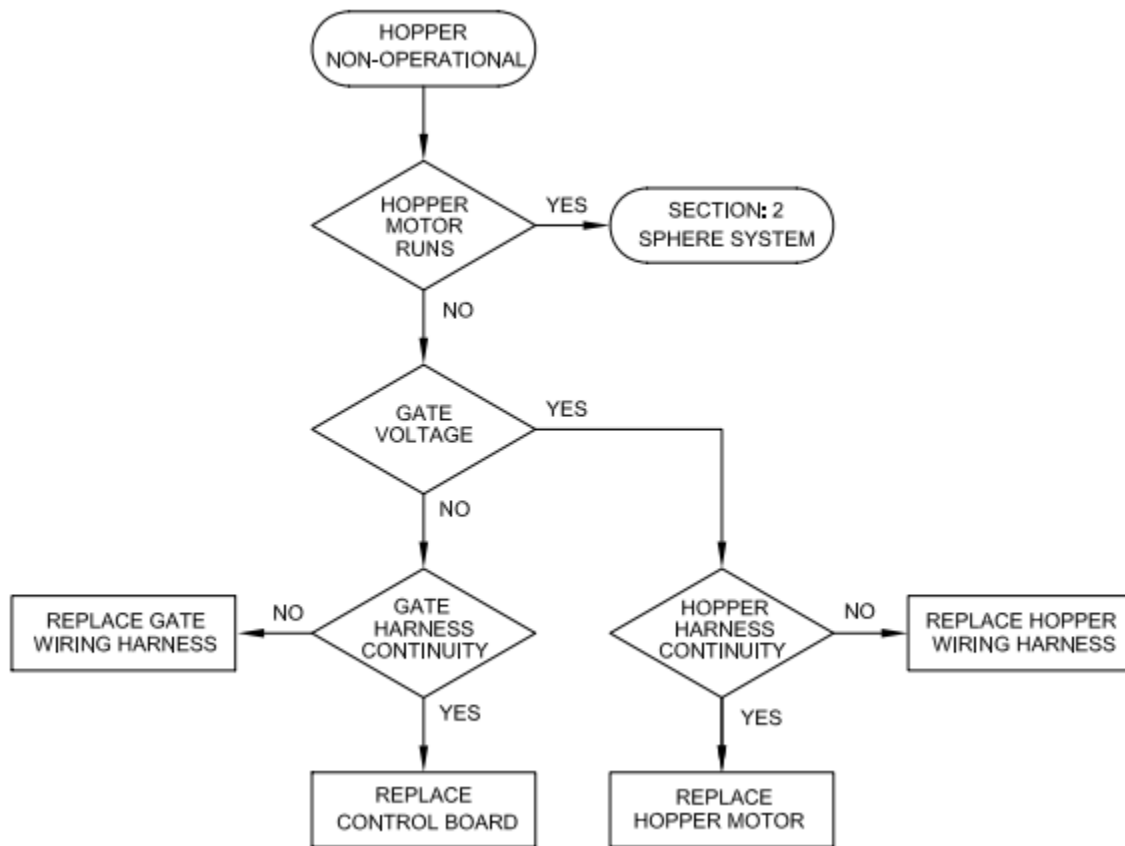

Sphere Handling System

- Set the “RUN / STOP” switch to “RUN.”
- If the hopper motor runs, go to *Section 2: Sphere Handling System*

Gate Voltage

- Remove the hopper from the gate assembly.
- Measure the voltage across socket “1” and socket “2” of the gate receptacle (see below).
- If the voltage is equal to the supply voltage go to subsection *Hopper Wiring Harness Damaged*.



Section5: Control System

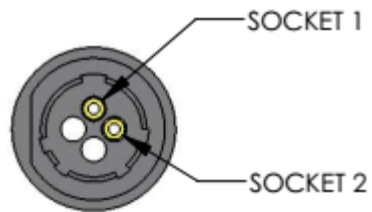

Gate Wiring Harness Damaged

- Disconnect the power cord from the external power supply.
- Remove the four #10-24 x 3/8 button head capscrews which secure the control panel to the tank assembly.
- Tilt the control panel forwards to access the main control board.



- Disconnect the gate wiring harness plug from the main control board.
- Check the continuity between socket “1” on the gate wiring harness plug and socket “1” on the gate receptacle.

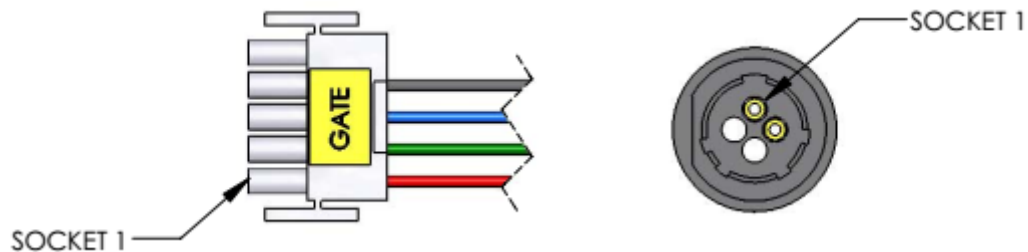

- If there is no continuity, replace the gate wiring harness.

Section5: Control System

- Check the continuity between socket “4” on the gate wiring harness plug and socket “2” on the gate receptacle.
- If there is no continuity, replace the gate wiring harness.

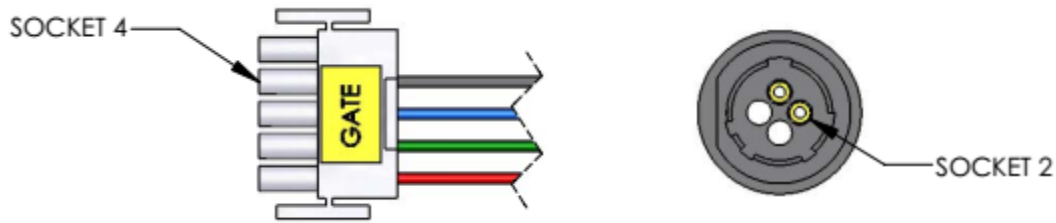

Control Board Damaged

- Replace the main control board.

Hopper Wiring Harness Damaged

- Remove the four #10-24 x 3/8 button head capscrews which secure the agitator assembly to the hopper body.



- Remove the agitator assembly.
- Disconnect the bullet connectors which connect the hopper wiring harness to the hopper motor.



Section5: Control System

- Check the continuity between the male bullet connector and pin “1”
- If there is no continuity, replace the hopper wiring harness.
- Check the continuity between the female bullet connector and pin “2”
- If there is no continuity, replace the hopper wiring harness.

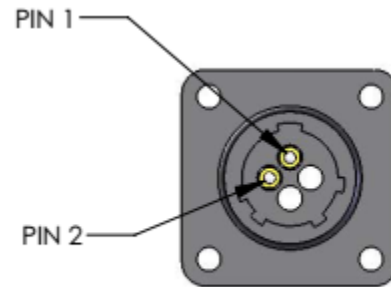
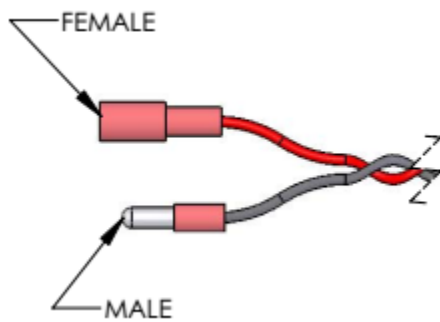

Hopper Motor Damaged

- Replace the hopper motor.

Section5: Control System

Feed Gates Won't Open

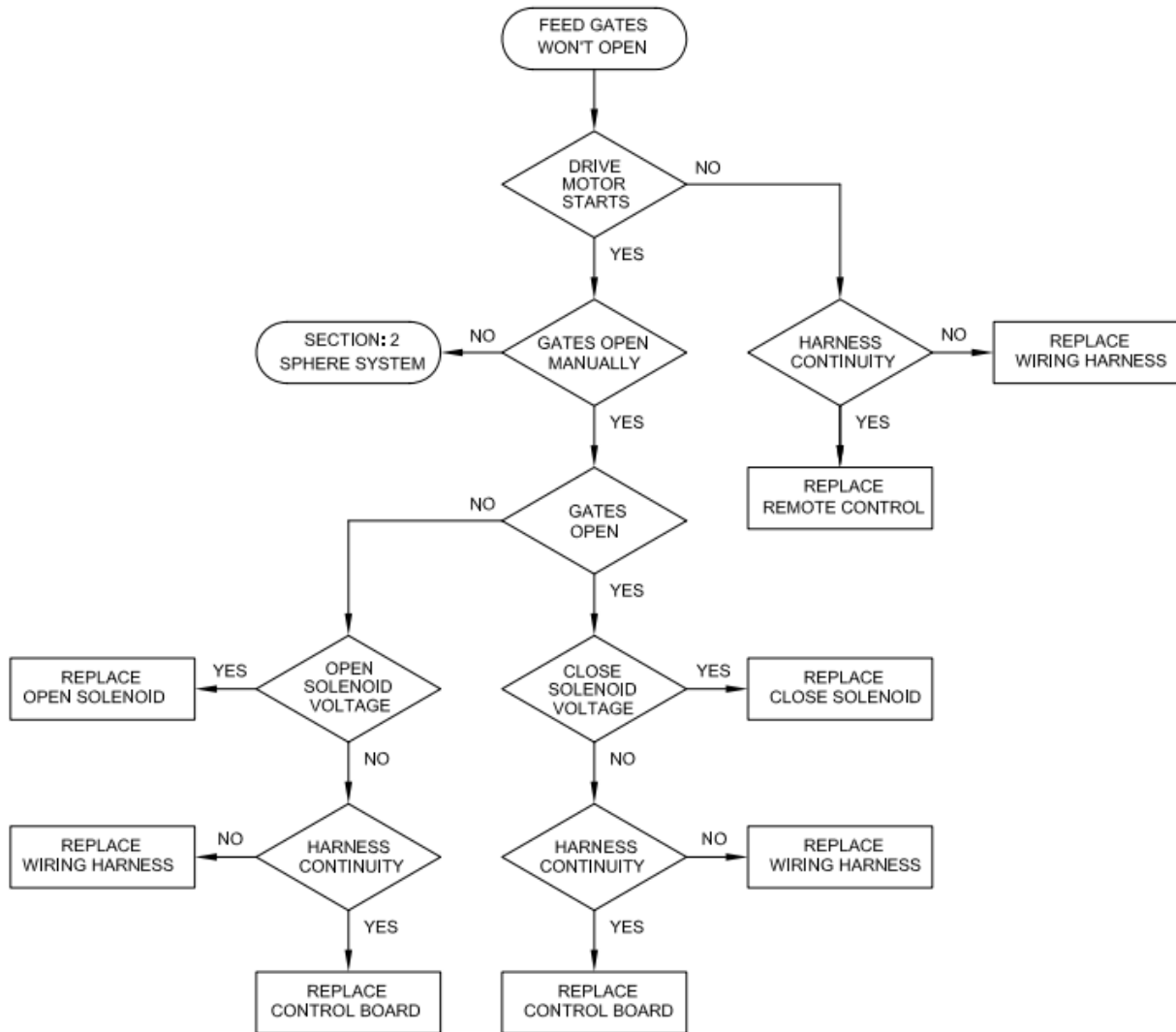

- Activate the open switch on the remote control.
- If the drive motor starts, go to subsection *Gates Open Manually*.

Section5: Control System

Remote Wiring Harness Damaged

- Disconnect the external power supply to the dispenser.
- Disconnect the remote control plug from the receptacle on the front of the dispenser.
- Remove the four #10-24 x 3/8 button head capscrews which secure the control panel to the tank assembly.
- Tilt the control panel forwards to access the main control board.



- Disconnect the remote wiring harness plug from the main control board.
- Check the continuity between socket "D" on the panel receptacle and socket "4" on the wiring harness plug.
- If there is no continuity, replace the remote wiring harness.

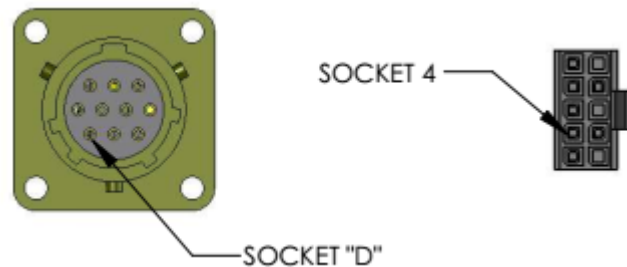

- Check the continuity between socket "F" on the panel receptacle and socket "7" on the wiring harness plug.
- If there is no continuity, replace the remote wiring harness.

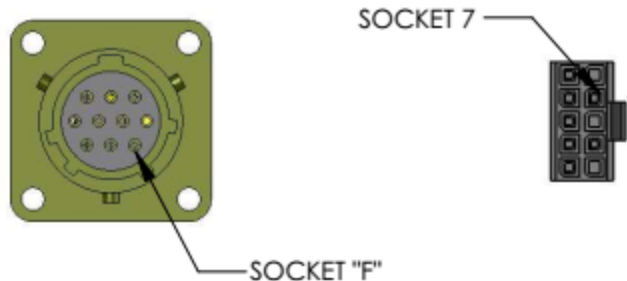

Remote Control Damaged

- Replace the remote control.

Gates Open Manually

- Ensure that the drive motor is stopped.
- Remove the gate assembly.
- Use a screwdriver to lift the locking pin and unlock the feed control rod.
- If the gates do not open go to *Section 2: Sphere Handling System*



Section5: Control System

Open Solenoid Damaged

- Press on the close solenoid core to try to relieve the pressure on the lock pin.
- Activate the open switch on the remote control
- If the gates open go to subsection *Close Solenoid Damaged*.



- Activate the close switch on the remote control and wait until the drive motor stops.
- Measure the voltage across the open solenoid terminals while activating the open switch on the remote control.
- If there is a transient voltage increase, replace the open solenoid



Gate Wiring Harness Damaged

- Disconnect the external power supply to the dispenser.
- Remove the four #10-24 x 3/8 button head capscrews which secure the control panel to the tank assembly.
- Tilt the control panel forwards to access the main control board.



Section5: Control System

- Disconnect the gate wiring harness plug from the main control board.
- Check the continuity between socket “1” on the harness plug and the red wire on the open solenoid.
- If there is no continuity, replace the gate wiring harness.

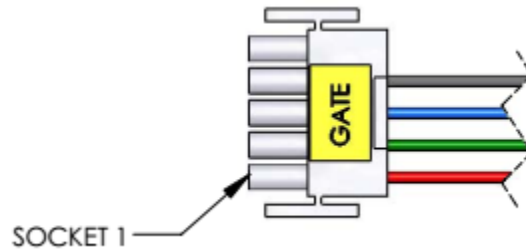

- Check the continuity between socket “2” on the harness plug and the green wire on the open solenoid.
- If there is no continuity, replace the gate wiring harness

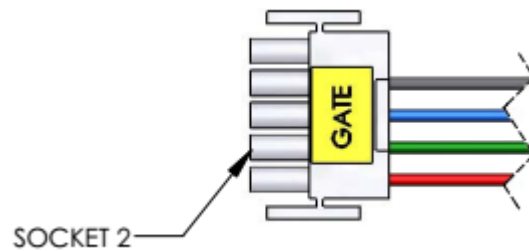

Section5: Control System

Control Board Damaged

- Replace the main control board.

Close Solenoid Damaged

- Activate the close switch on the remote control and wait until the drive motor stops.
- Measure the voltage across the close solenoid terminals while activating the open switch on the remote control.
- If there is a transient voltage increase, replace the close solenoid.



Gate Wiring Harness Damaged

- Disconnect the external power supply to the dispenser.
- Remove the four #10-24 x 3/8 button head capscrews which secure the control panel to the tank assembly.
- Tilt the control panel forwards to access the main control board.



- Disconnect the gate wiring harness plug from the main control board.
- Check the continuity between socket “1” on the harness plug and the red wire on the open solenoid.
- If there is no continuity, replace the gate wiring harness.

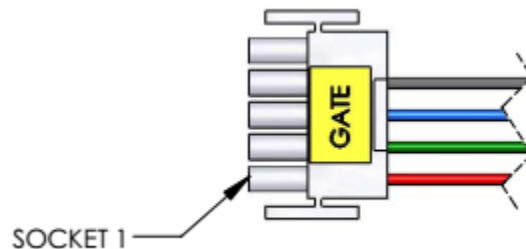

Section5: Control System

- Check the continuity between socket “3” on the harness plug and the green wire on the open solenoid.
- If there is no continuity, replace the gate wiring harness.

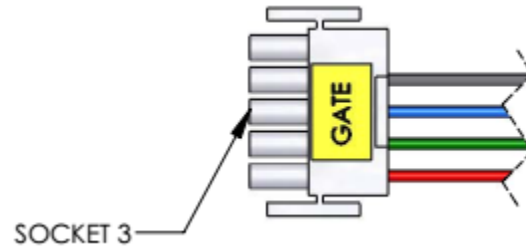

Control Board Damaged

- Replace the main control board.

Section5: Control System

Drive Mechanism Non-Operational

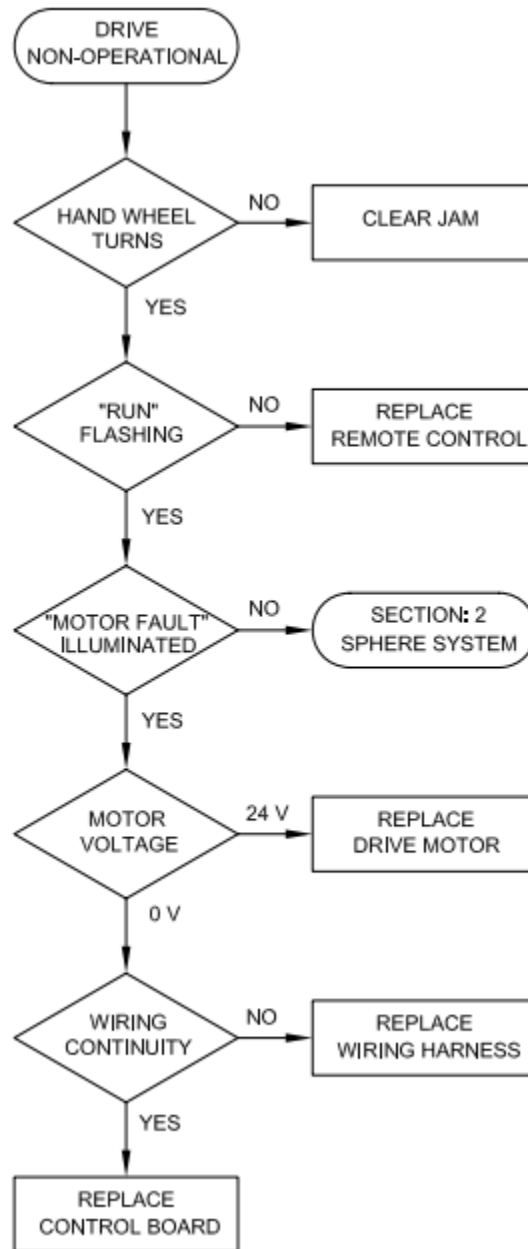

Section5: Control System

Hand Wheel Turns

- Remove the gate assembly.
- Rotate the manual hand wheel.
- If the hand wheel does not turn, clear the jam.

Remote Control Damaged

- If the “RUN” indicator on the main control panel is not flashing, replace the remote control.

Control System

- If the “MOTOR FAULT” indicator on the main control panel is not illuminated, go to *Section 2: Sphere Handling System*.

Drive Motor Damaged

- Measure the voltage across the drive motor terminals.
- If the voltage is approximately equal to the supply voltage (24V), replace the drive motor.

Motor Wiring Harness Damaged

- Remove the four #10-24 x 3/8 button head capscrews which secure the control panel to the tank assembly.
- Tilt the control panel forwards to access the main control board.
- Unplug the motor wiring harness from the main control board.



Section5: Control System

- Measure the continuity between the red motor lead and socket # 1 on the harness plug.
- If there is no continuity, replace the wiring harness.

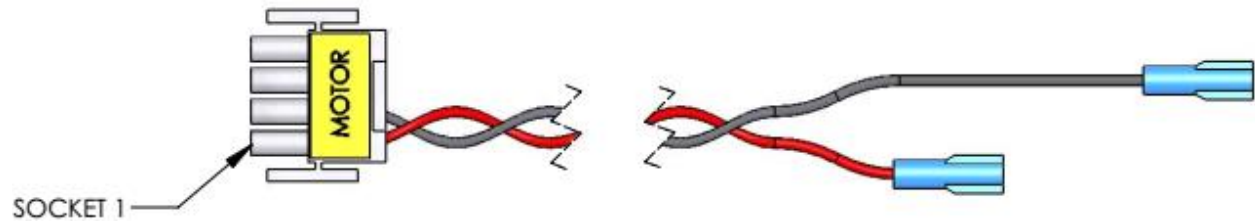

- Measure the continuity between the black motor lead and socket # 2 on the harness plug.
- If there is no continuity, replace the wiring harness.

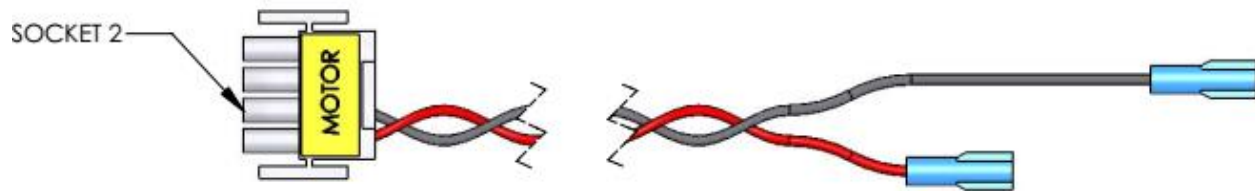

Control Board Damaged

- Replace the main control board.

Feed Gates Won't Close

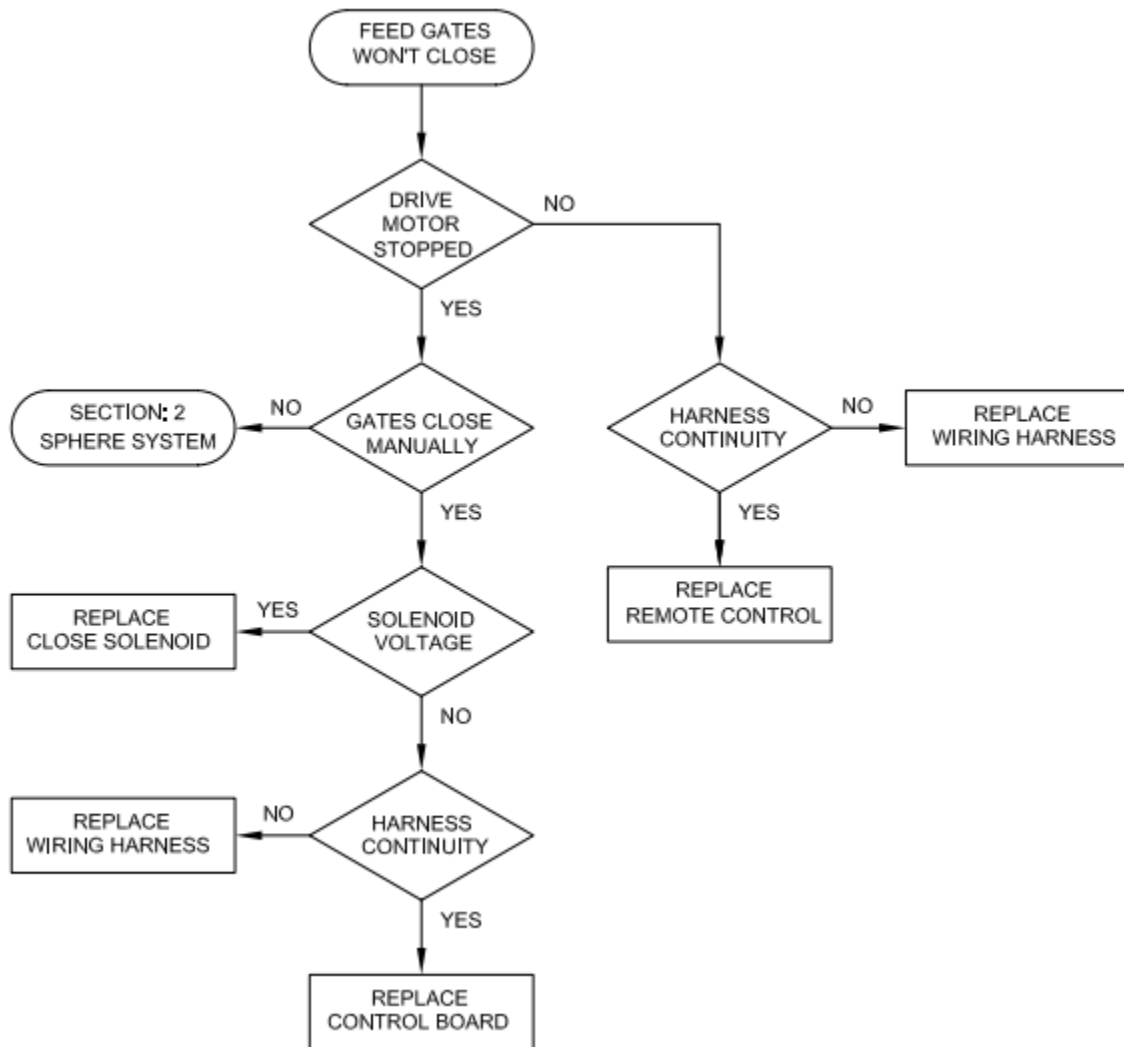

- Activate the close switch on the remote control.
- If the drive motor stops, go to subsection *Gates Close Manually*.

Section5: Control System

Remote Wiring Harness Damaged

- Disconnect the external power supply to the dispenser.
- Disconnect the remote control plug from the receptacle on the front of the dispenser.
- Remove the four #10-24 x 3/8 button head capscrews which secure the control panel to the tank assembly.
- Tilt the control panel forwards to access the main control board.



- Disconnect the remote wiring harness plug from the main control board.
- Check the continuity between socket “E” on the panel receptacle and socket “5” on the wiring harness plug.
- If there is no continuity, replace the remote wiring harness.

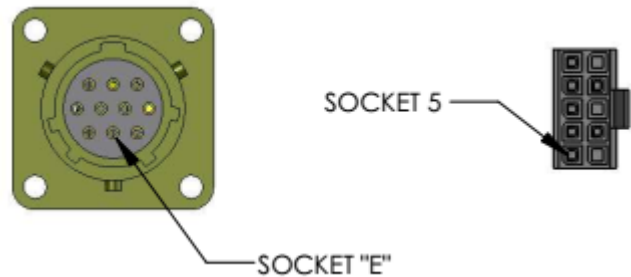

- Check the continuity between socket “F” on the panel receptacle and socket “7” on the wiring harness plug.
- If there is no continuity, replace the remote wiring harness.

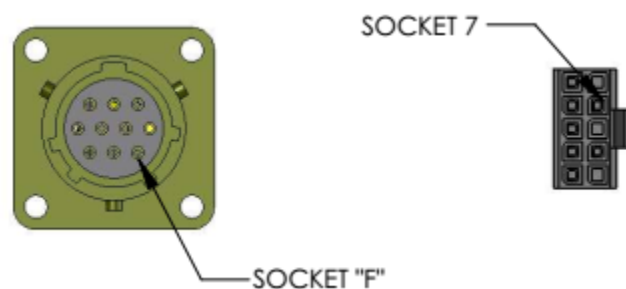

Section5: Control System

Remote Control Damaged

- Replace the remote control.

Gates Close Manually

- Remove the gate assembly.
- Press on the close solenoid core to try to close the gate.
- If the gates do not close and lock, go to *Section 2: Sphere Handling System*



Close Solenoid Damaged

- Activate the open switch on the remote control.
- Measure the voltage across the close solenoid terminals while activating the close switch on the remote control.
- If there is a transient voltage increase, replace the close solenoid.



Section5: Control System

Gate Wiring Harness Damaged

- Disconnect the external power supply to the dispenser.
- Remove the four #10-24 x 3/8 button head capscrews which secure the control panel to the tank assembly.
- Tilt the control panel forwards to access the main control board.
- Disconnect the gate wiring harness plug from the main control board.



- Check the continuity between socket “1” on the harness plug and the red wire on the close solenoid.
- If there is no continuity, replace the gate wiring harness.

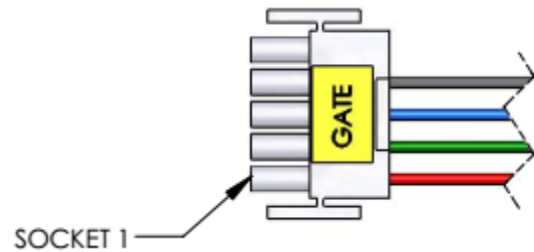

- Check the continuity between socket “3” on the harness plug and the blue wire on the close solenoid.
- If there is no continuity, replace the gate wiring harness.

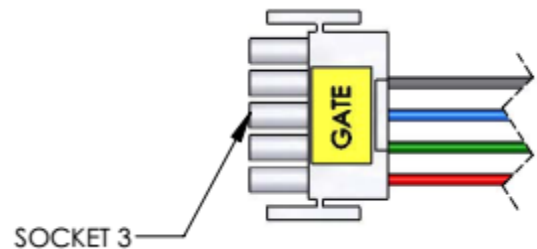

Control Board Damaged

- Replace the main control board.

Section 6: Repairs for All Systems

Hopper Repairs

Hopper Motor Replacement

- Remove the four # 10-24 x 3/8 button head capscrews which secure the agitator mechanism to the hopper body.



- Remove the agitator mechanism from the hopper body



- Loosen the # 8-32 setscrew which secures the agitator cam to the hopper motor shaft.



Section 6: Repairs for All Systems

- Remove the two # 10-32 x 3/8 screws which secure the hopper motor to the hopper base.

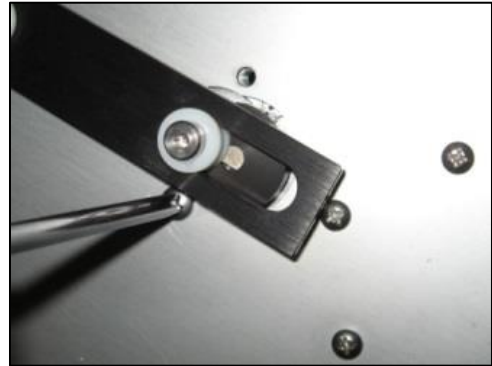

- Disconnect the hopper wiring harness from the hopper motor terminals.
- Remove the hopper motor from the agitator assembly.
- Install the new hopper motor into the agitator assembly and secure to the hopper base using two #10-32 x 3/8 screws.
- Attach the hopper wiring harness to the hopper motor.



- Align the motor shaft flat with the setscrew in the agitator cam and tighten the setscrew.



- Replace the agitator mechanism into the hopper body and secure using four # 10-24 x 3/8 button head capscrews.

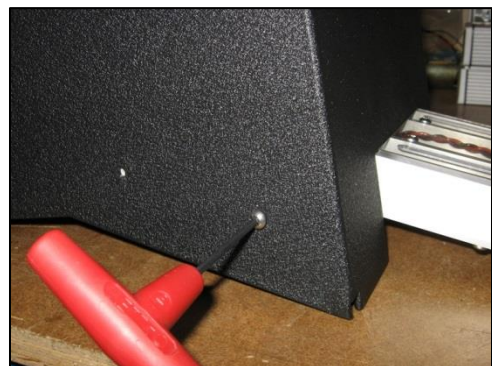

Section 6: Repairs for All Systems

- Adjust the agitator adjuster mechanism as required.



- Install the hopper onto the gate assembly.
- Connect the dispenser to an external power supply.
- Check that the “POWER” indicator illuminates.
- Switch the “RUN/STOP” switch to the “RUN” position.
- Check that the hopper agitator operates.

Hopper Motor Wiring Harness Replacement

- Remove the four # 10-24 x 3/8 button head capscrews which secure the agitator mechanism to the hopper body.

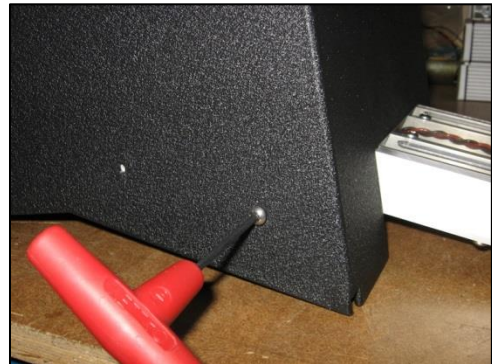

- Remove the agitator mechanism from the hopper body



Section 6: Repairs for All Systems

- Remove the four # 4-40 x 3/8 screws which secure the wiring harness receptacle to the agitator assembly.

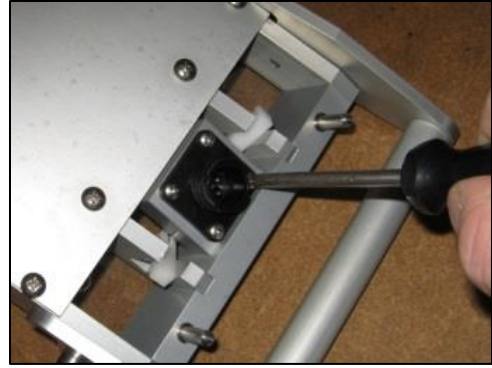

- Disconnect the hopper wiring harness from the hopper motor terminals.
- Remove the hopper wiring harness.
- Install the new hopper wiring harness into the agitator assembly.
- Secure the wiring harness receptacle to the agitator assembly using four # 4-40 x 3/8 screws.
- Connect the hopper wiring harness to the hopper motor.
- Replace the agitator mechanism into the hopper body and secure using four # 10-24 x 3/8 button head capscrews.

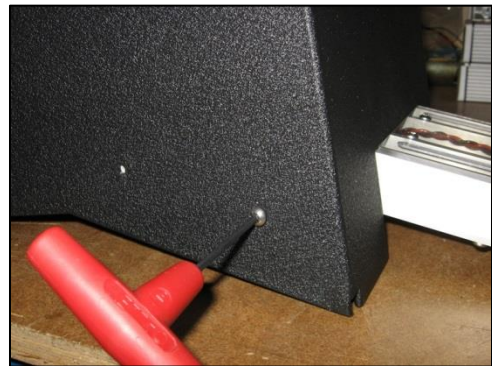

- Adjust the agitator adjuster mechanism as required.



Section 6: Repairs for All Systems

- Install the hopper onto the gate assembly.
- Connect the dispenser to an external power supply.
- Check that the “POWER” indicator illuminates.
- Switch the “RUN/STOP” switch to the “RUN” position.
- Check that the hopper agitator operates.

Section 6: Repairs for All Systems

Feed Gate Repairs

Feed Control Spring Replacement

- Loosen screw which secures the manual feed gate knob to the feed control rod.
- Un-thread the knob from the feed control rod.
- Remove the feed control spring.



- Install the new spring onto the rod.
- Thread the knob onto the rod until the face of the knob is 3/4" from the face of the pillow block which supports the feed control rod.
- Secure the knob in place using the setscrew.
- Install the gate assembly onto the injection head.



- Connect the dispenser to an external power supply.
- Check that the "POWER" indicator illuminates.
- Switch the "RUN/STOP" switch to the "RUN" position.
- Press the feed gate switch to the "OPEN" position.
- Check that the feed gates open.

Solenoid Activator Adjustment

- Loosen the setscrews which secure the solenoid activator to the control rod.



Section 6: Repairs for All Systems

- Press on the close solenoid core to try to fully extend the pin on the close solenoid.

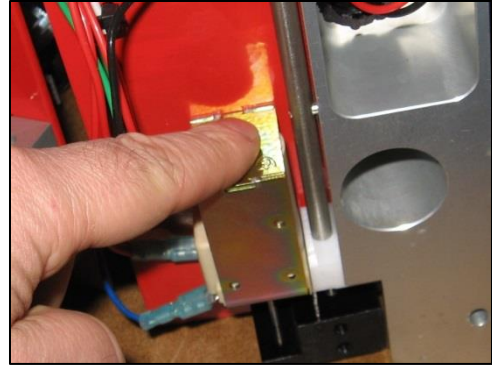

- Adjust the position of the control rod so that the locking pin on the open solenoid aligns with the groove in the feed control rod.

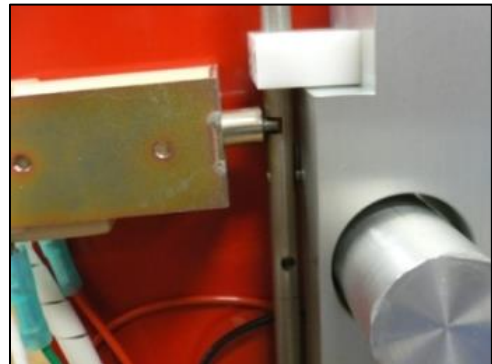





- Adjust the solenoid activator to touch the pin of the close solenoid.
- Secure the activator in place with its setscrews.



- Install the gate assembly onto the injection head.
- Connect the dispenser to an external power supply.
- Check that the “POWER” indicator illuminates.
- Switch the “RUN/STOP” switch to the “RUN” position.
- Press the feed gate switch to the “OPEN” position.
- Wait ten seconds and press the switch to the “CLOSE” position.
- Check that the feed gates close and lock.

Section 6: Repairs for All Systems

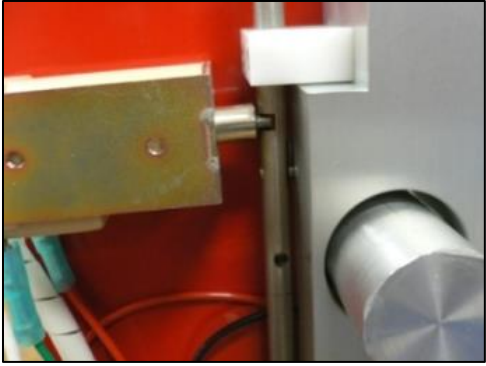
Open Solenoid Replacement

- Remove the gate assembly from the injection head
 - Disconnect the gate wiring harness wires from the open solenoid terminals.
- 
- Remove the two # 6-32 x 3/16 screws which secure the solenoid to the solenoid cover.
 - Remove the solenoid.
- 
- Install the new solenoid onto the solenoid cover and secure using two #6-32 x 3/16 screws, but do not tighten.
 - Press on the close solenoid core and adjust the open solenoid position so that the locking pin aligns with groove in the feed control rod.
 - Tighten the screws to secure the solenoid in place.
- 
- Replace the gate wiring harness wires onto the open solenoid terminals.
- 

Section 6: Repairs for All Systems

- Install the gate assembly onto the injection head.
- Connect the dispenser to an external power supply.
- Check that the “POWER” indicator illuminates.
- Switch the “RUN/STOP” switch to the “RUN” position.
- Press the feed gate switch to the “OPEN” position.
- Check that the feed gates open.

Close Solenoid Replacement

- Remove the gate assembly from the injection head
- Disconnect the gate wiring harness wires from the close solenoid terminals.



- Remove the four # 6-32 x 3/16 screws which secure the solenoid to the solenoid cover.
- Remove the solenoid.



- Install the new solenoid onto the solenoid cover and secure using two #6-32 x 3/16 screws, but do not tighten.
- Press on the close solenoid core and adjust the close solenoid position so that the locking pin on the open solenoid aligns with groove in the feed control rod.
- Tighten the screws to secure the solenoid in place.

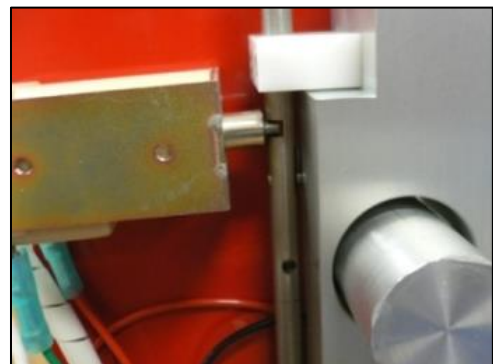

Section 6: Repairs for All Systems

- Replace the gate wiring harness wires onto the close solenoid terminals.



- Install the gate assembly onto the injection head.
- Connect the dispenser to an external power supply.
- Check that the “POWER” indicator illuminates.
- Switch the “RUN/STOP” switch to the “RUN” position.
- Press the feed gate switch to the “OPEN” position.
- Wait ten seconds and press the switch to the “CLOSE” position.
- Check that the feed gates close.

Gate Wiring Harness Replacement

- Disconnect the dispenser from the external power supply.
- Remove the four # 10-24 x 3/8 button head capscrews which secure the control panel to the tank assembly.
- Tilt the control panel forwards to access the main control board.
- Unplug the gate wiring harness from the main control board



- Remove the four #10-24 x 3/8 button head capscrews which secure the lower control cover to the tank assembly.
- Remove the control cover.



Section 6: Repairs for All Systems

- Remove the tie wrap which secures the motor and pump wiring harnesses to the gate wiring harness.
- Remove the # 10-32 x 3/8 button head capscrew and P-clip which secures the wiring harness in place.



- Remove the gate assembly from the injection head.
- Cut and remove the tie wrap which secures the gate wiring harness to the solenoid cover.



- Disconnect the wiring harness connectors from the open solenoid.
- Disconnect the wiring harness connectors from the close solenoid.

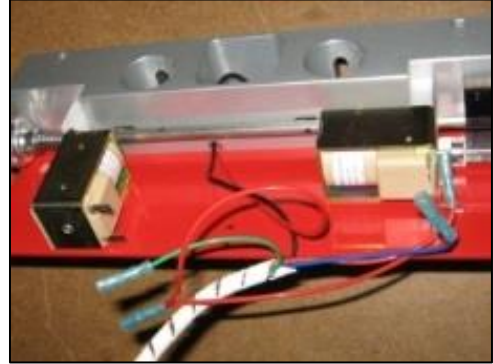

- Disconnect the two wires from the gate receptacle using special extraction tool AMP # 305183.
- Remove the wiring harness from the gate assembly.



Section 6: Repairs for All Systems

- Install the new wiring harness onto the gate assembly.
- Install the red lead into receptacle socket # 1.
- Install the black lead into receptacle socket # 2.
- Attach the red and green leads to the open solenoid.
- Attach the red and blue leads to the close solenoid.
- Secure the wire harness to the gate assembly using a tie wrap.

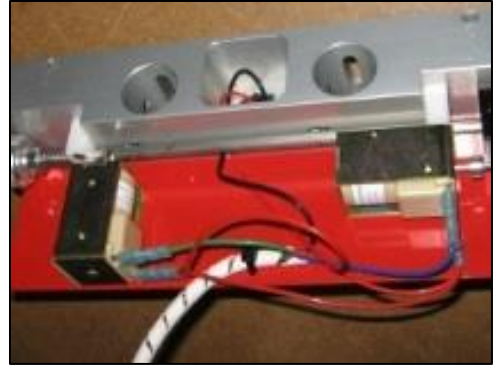

- Route the wiring harness and plug into the main control board.
- Replace the lower control cover and secure in place using four # 10-24 x 3/8 button head capscrews.



- Secure the gate wiring harness to the tank assembly using the P-clip.
- Replace the tie wrap which secures the pump and motor wiring harnesses to the gate wiring harness.



- Install the gate assembly onto the injection head.
- Install the hopper onto the gate assembly.
- Connect the dispenser to an external power supply.
- Check that the “POWER” indicator illuminates.
- Switch the “RUN/STOP” switch to the “RUN” position.

Section 6: Repairs for All Systems

- Check that the hopper agitator operates
- Press the feed gate switch to the “OPEN” position.
- Check that the feed gates open.
- Wait ten seconds and press the switch to the “CLOSE” position.
- Check that the feed gates close.

Section 6: Repairs for All Systems

Injection Head Repairs

Drive Coupling Disk Replacement

- Remove the gate assembly.
- Loosen the setscrew on the motor shaft coupling hub.
- Remove the two #10-32 x 1-3/4 socket head capscrews which secure the motor mount to the injection head.
- Remove the motor and motor mount being careful to support the motor so that the wires are not strained.
- Remove the connector disk.
- Install the new connector disk onto the drive shaft.
- Attach the motor mount to the injection head and secure using two #10-32 x 1-3/4 socket head capscrews.
- Adjust the motor shaft coupling against the disc and tighten the setscrew on the motor shaft coupling hub.
- Replace the gate assembly.

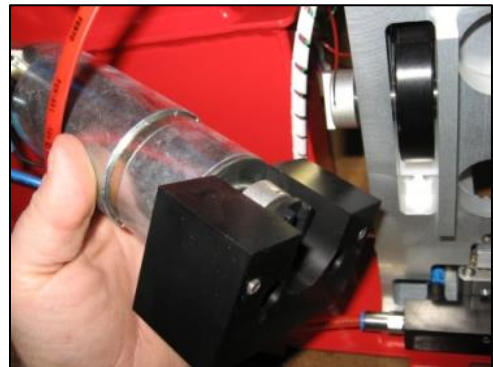
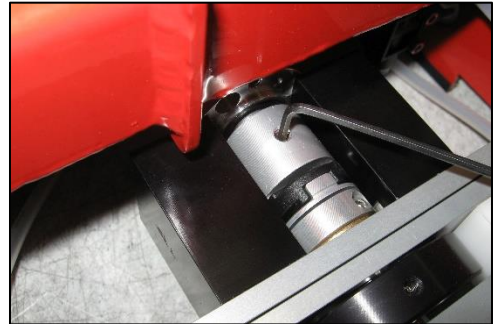

Section 6: Repairs for All Systems

Drive Motor Replacement

- Disconnect the dispenser from external power supply.
- Remove the four # 10-24 x 3/8 button head capscrews which secure the control panel to the tank assembly.
- Tilt the control panel forwards to access the main control board.
- Unplug the motor encoder from the tracker harness.
- Unplug the motor power from the control board.



- Remove the four #10-24 x 3/8 button head capscrews which secure the lower control cover to the tank assembly.
- Remove the control cover.

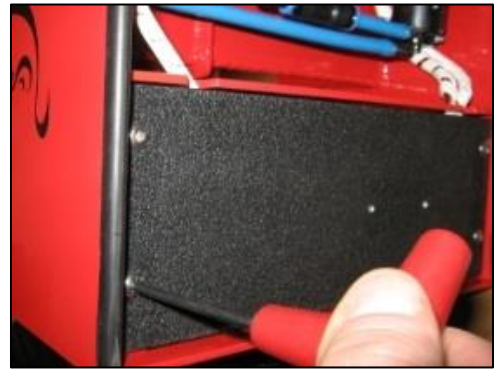

- Remove the P-clip which secures the encoder and level switch wires to the tank assembly.
- Remove the spiral wrap from the encoder and level switch wires.



- Remove the gate assembly.
- Loosen the setscrew on the motor shaft coupling hub.



Section 6: Repairs for All Systems

- Remove the two #10-32 x 1-3/4 socket head capscrews which secure the motor mount to the injection head.



- Remove the motor and motor mount.
- Remove the two M4 X 50mm socket head capscrews which secure the motor to the motor mount.
- Remove the coupling hub from the motor.
- Install the motor mount onto the new motor and secure in place using two M4 X 50mm socket head capscrews.
- Install the coupling hub onto the motor shaft but do not tighten the setscrew.



- Attach the motor mount to the injection head and secure using two #10-32 x 1-3/4 socket head capscrews.
- Adjust the motor shaft coupling against the disc and tighten the setscrew on the motor shaft coupling hub.
- Replace the gate assembly.



- Replace the spiral wrap on the encoder and level switch wires.
- Replace the P-clip which secures the encoder and level switch wires to the tank assembly.



Section 6: Repairs for All Systems

- Replace the lower control cover and secure in place using four # 10-24 x 3/8 button head capscrews.



- Plug the motor encoder into the tracker harness.
- Plug the motor power lead into the control board.
- Replace the control panel and secure using four # 10-24 x 3/8 button head capscrews.



- Connect the dispenser to an external power supply.
- Check that the “POWER” indicator illuminates.
- Switch the “RUN/STOP” switch to the “RUN” position.
- Press the feed gate switch to the “OPEN” position.
- Check that the drive motor operates.

Section 6: Repairs for All Systems

Glycol System Repairs

Inlet Check Valve Replacement

- Unscrew the inlet check valve from the manifold block.
- Install new inlet check valve in manifold block.



- Press and hold the pump arm.
- Hold the glycol supply line over the inlet check valve so that the valve fills with glycol.
- Reconnect the supply line into the check valve.
- Release the pump arm.
- Press and release the pump arm repeatedly until the pump primes.



Outlet Check Valve Replacement

- Un-thread the elbow from the manifold block.



Section 6: Repairs for All Systems

- Remove elbow and tube from outlet check valve.
- Un-thread the outlet check valve from the manifold block.



- Install new outlet check valve in manifold block.
- Replace elbow and tube into check valve.
- Install elbow into manifold block.



- Press and hold the pump arm.
- Hold the glycol supply line over the inlet check valve so that the valve fills with glycol.
- Reconnect the supply line into the check valve.
- Release the pump arm.
- Press and release the pump arm repeatedly until the pump primes.



Glycol Pump Replacement

- Remove the 3mm x 1.5 socket head capscrew that secures the pump arm to the pump piston.
- Remove the pump arm.



Section 6: Repairs for All Systems

- Remove four # 6-32 x 7/8 socket head capscrews that secure the pump to the manifold block.
- Remove the pump.



- Remove the O-ring from the pump.
- Install the O-ring onto the new pump.



- Replace the pump onto the manifold block.
- Hold pressure on the O-ring and secure the pump cylinder to the manifold block using four #6-32 x 7/8 socket head capscrews.



- Replace the pump arm and secure to the pump piston using the 3mm x 1.5 socket head capscrews.



Section 6: Repairs for All Systems

- Press and hold the pump arm.
- Hold the glycol supply line over the inlet check valve so that the valve fills with glycol.
- Reconnect the supply line into the check valve.
- Release the pump arm.
- Press and release the pump arm repeatedly until the pump primes.



Suction Line Replacement

- Drain the glycol tank.
- Remove the suction line from the tank adapter fitting.
- Check that the tank adapter fitting is not plugged.
- Install new suction line into the tank adapter fitting.



- Press and hold the pump arm.
- Hold the glycol supply line over the inlet check valve so that the valve fills with glycol.
- Reconnect the supply line into the check valve.
- Release the pump arm.
- Press and release the pump arm repeatedly until the pump primes.



Injection Needle Replacement

- Remove the 3mm x 1.5 socket head capscrew that secures the pump arm to the pump piston.
- Remove the pump arm.



Section 6: Repairs for All Systems

- Remove the injection needle from the manifold block.
- Repair or replace the needle in the manifold block.

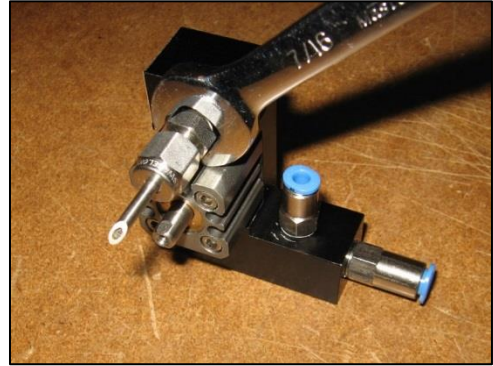

- Replace the pump arm and secure to the pump piston using the 3mm x 1.5 socket head capscrews.



- Replace the elbow and tubing into the outlet check valve.
- Replace the elbow into the manifold block.



- Press and hold the pump arm.
- Hold the glycol supply line over the inlet check valve so that the valve fills with glycol.
- Reconnect the supply line into the check valve.
- Release the pump arm.
- Press and release the pump arm repeatedly until the pump primes.



Water System Repairs

Check Valve Replacement

- Disconnect the water line from the inlet side of the check valve and cap the water line.
- Disconnect the water valve from the outlet side of the check valve.



- Replace the check valve ensuring proper orientation.



Water Pump Replacement

- Drain the water tank using the tank drain valve.
- Disconnect the pump wiring harness from the pump motor.



Section 6: Repairs for All Systems

- Disconnect the pump suction line from the elbow in the bottom of the water tank.
- Disconnect the pump discharge line from the T-fitting.



- Remove the lower # 10-24 x 3/8 button head capscrew that secures the pump bracket.
- Pivot the bracket around the remaining capscrew and remove the water pump complete with the suction and discharge tubing.



- Cut a piece of 8mm x 7-3/4" blue tubing and install on the new pump suction port.
- Cut a piece of 8mm x 2-1/2" blue tubing and install on the new pump discharge port.



- Install the pump and bracket, and secure with the # 10-24 x 3/8 button head capscrew.



Section 6: Repairs for All Systems

- Connect the pump suction tube to the elbow in the bottom of the water tank.
- Connect the pump discharge tube to the T fitting.



- Connect the black pump lead of the wiring harness to the negative terminal of the pump.
- Connect the red pump lead of the wiring harness to the positive terminal of the pump.



Water Pump Wiring Harness Replacement

- Disconnect the dispenser from external power supply.
 - Remove the four # 10-24 x 3/8 button head capscrews which secure the control panel to the tank assembly.
 - Tilt the control panel forwards to access the main control board.
 - Unplug the pump wiring harness from the main control board.
-
- Remove the four #10-24 x 3/8 button head capscrews which secure the lower control cover to the tank assembly.
 - Remove the control cover.



Section 6: Repairs for All Systems

- Remove the tie wrap which secures the pump and motor wiring harnesses to the gate wiring harness.
- Remove the spiral wrap from the pump and motor wiring harnesses.
- Disconnect the pump wiring harness from the pump.
- Remove the pump wiring harness.

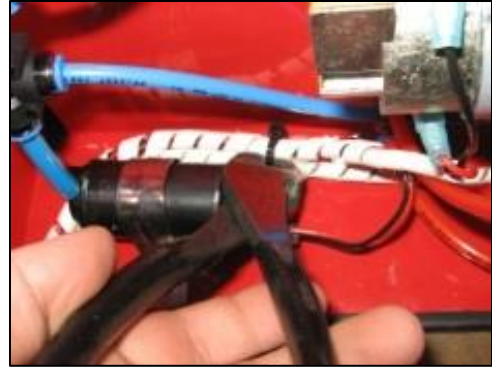

- Attach the new pump wiring harness to the pump ensuring that the red lead is attached to the positive terminal



- Replace the spiral wrap onto the pump and motor wiring harnesses.
- Secure the pump and motor wiring harnesses to the gate wiring harness using a tie wrap.
- Install the wiring in the cutout above the lower control cover.



- Replace the lower control cover and secure in place using four #10-24 x 3/8 button head capscrews.



Section 6: Repairs for All Systems

- Plug the pump wiring harness into the main control board.
- Replace the control panel and secure using four # 10-24 x 3/8 button head capscrews.
- Press the “WATER” switch to the “ON” position.
- Check that water pump operates.



Level Switch Replacement

- Disconnect the dispenser from external power supply.
- Remove the four # 10-24 x 3/8 button head capscrews which secure the control panel to the tank assembly.
- Tilt the control panel forwards to access the main control board.
- Unplug the level switch from the main control board.



- Remove the four #10-24 x 3/8 button head capscrews which secure the lower control cover to the tank assembly.
- Remove the control cover.



- Remove the P-clip which secures the encoder and level switch wires to the tank assembly.
- Remove the spiral wrap from the encoder and level switch wires.



Section 6: Repairs for All Systems

- Remove the three # 10-32 x 3/8 seal screws which secure the level switch to the tank.
- Remove the old level switch assembly.



- Install the new level switch and O-ring into the tank and secure using three # 10-32 x 3/8 seal screws. Replace the spiral wrap onto the encoder and level switch wires.
- Secure the wires in place using a # 10-32 x 3/8 button head capscrew and a P-clip.

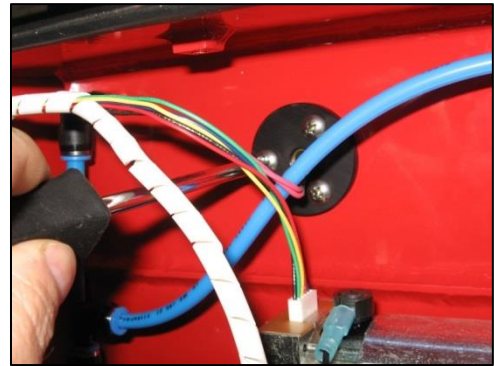

- Install the wiring in the cutout above the lower control cover.
- Replace the lower control cover and secure in place using four #10-24 x 3/8 button head capscrews.



- Plug the level switch into the main control board.
- Replace the control panel and secure using four # 10-24 x 3/8 button head capscrews.



Section 6: Repairs for All Systems

- Connect the dispenser to an external power supply.
- Check that the “POWER” indicator illuminates.
- Wait five seconds and check that the “LOW WATER” indicator illuminates.
- Fill the water tank.
- Check that the “LOW WATER” indicator extinguishes.

Control System Repairs

Main Circuit Breaker Replacement

- Disconnect the dispenser from external power supply.
- Remove the four # 10-24 x 3/8 button head capscrews which secure the control panel to the tank assembly.
- Tilt the control panel forwards to access the main circuit breaker.
- Remove the nut on the front of the panel which secures the circuit breaker.
- Disconnect the power wiring harness from the main circuit breaker.



Section 6: Repairs for All Systems

- Check that the replacement circuit breaker is a 5A type MS3220 breaker.
- Cut away the locating tab on the new circuit breaker using side cutters.



- Reconnect the red and white power harness wires to the new circuit breaker.
- Install the circuit breaker into the front panel and secure with the nut.
- Replace the control panel and secure with four # 10-24 x 3/8 button head screws.



- Pull out the circuit breaker to the tripped position.
- Connect the dispenser to an external power supply.
- Check that the “POWER” indicator on the main control panel is not illuminated.
- Push in the circuit breaker to reset
- Check that the “POWER” indicator on the main control panel illuminates.

Power Wiring Harness Replacement

- Disconnect the dispenser from external power supply.
- Remove the four # 10-24 x 3/8 button head capscrews which secure the control panel to the tank assembly.
- Tilt the control panel forwards to access the main circuit breaker.



Section 6: Repairs for All Systems

- Remove the nut on the front of the panel which secures the circuit breaker.



- Disconnect the power wiring harness from the main circuit breaker.



- Cutaway the plug on the old wiring harness.



- Loosen the nut on the strain relief.
- Remove the old wiring harness by pulling it through the strain relief.



Section 6: Repairs for All Systems

- Install the new wiring harness into the front panel so that the insulation on the cable jacket protrudes approximately 1/4" past the strain relief.
- Tighten the strain relief.



- Install the plug onto the wiring harness with the red lead in socket # 1 and the black lead into socket # 2.
- Plug the wiring harness into the main control board.



- Connect the new power harness to the main circuit breaker.
- Replace the circuit breaker into the front panel.
- Replace the control panel and secure with four # 10-24 x 3/8 button head screws.



- Connect the dispenser to an external power supply.
- Push in the circuit breaker to reset.
- Check that the "POWER" indicator on the main control panel illuminates.

Section 6: Repairs for All Systems

Battery Replacement

- Disconnect the dispenser from external power supply.
- Remove the four # 10-24 x 3/8 button head capscrews which secure the control panel to the tank assembly.
- Tilt the control panel forwards to access the main control board.



- Unplug the battery from the main control board.
- Remove the old battery.
- Install the new battery and connect to the main control board.



- Replace the control panel and secure in place using four #10-24 x 3/8 button head capscrews.
- Press the “WATER” switch to the “ON” position.
- Check that water flows from both water nozzles.



Section 6: Repairs for All Systems

Main Control Board Replacement

- Disconnect the dispenser from external power supply.
- Remove the four # 10-24 x 3/8 button head capscrews which secure the control panel to the tank assembly.
- Tilt the control panel forwards to access the main control board.



- Unplug the battery from the main control board.
- Unplug the pump wiring harness.
- Unplug the power wiring harness.
- Unplug the gate wiring harness.
- Unplug the motor wiring harness.



- Unplug the tracker wiring harness.
- Unplug the level switch.
- Unplug the remote control wiring harness.



Section 6: Repairs for All Systems

- Remove the control panel from the dispenser.
- Remove the switch boots from the three toggle switches.



- Remove the four # 8-32 x 1/4 screws which secure the main control board to the control panel.
- Remove the main control board.



- Install the new control board onto the control panel and secure using four # 8-32 x 1/4 screws.
- Replace the switch boots.



- Re-attach all of the electrical connections to the main control board.



Section 6: Repairs for All Systems

- Replace the control panel and secure in place using four #10-24 x 3/8 button head capscrews.



Section 7: Supplier Cross Reference

Section 7: Supplier Cross Reference

Supplier Chart

The purpose of this section is to provide a cross reference to alternate parts suppliers for the non-proprietary components used in the dispenser. The item number in the table corresponds to the item number used in the expanded drawings in the previous sections of the manual.

Contact information for the various suppliers can be found at the end of this section.

Item	Description	SEI Part #	Alternate Supplier	Supplier Part #
100	O-RING, BUNA N, # 007	005112	McMaster Carr	9452K15
101	ELBOW, STREET, 90°, 1/8NPT X 4MM	003643	Festo	153334
102	TUBING, POLYEHELENE, 4MM, CLEAR	012047	Festo	543246
103	VALVE, NON-RETURN, 1/8NPT X 4MM	004228	Festo	153446
104	VALVE, NON RETURN, 1/8NPT X 6MM	004230	Festo	153449
105	BUSHING, FLANGED, 3/8 X 1/2 X 5/16	005982	Symmco	SF-1216-5
106	KEY, MACHINE, C1018, SQ, 1/8 X 1/2	015194	McMaster Carr	98870A095
107	BUSHING, FLANGED, 1/2 X 5/8 X 1/4	005109	Symmco	SF-1620-4
108	COUPLING, OLDHAM, 1/4 X 40INLB	005137	Stock Drive Products	AFZ15-332508
109	SPRING, COIL COMP, PL, 3/8 OD X 1.1 LB/IN	005990	McMaster Carr	9657K33
111	O-RING, BUNA N, # 029	005993	McMaster Carr	9452K116
112	ELBOW, STREET, 90°, 1/8NPT X 8MM	003649	Festo	153048
113	PUMP	006003	NAPA	BK 6651593
114	PUMP BRACKET	002982	McMaster-Carr	8874T18
115	TEE, 8MM X 2, 6MM X 1	003660	Festo	153135
116	ELBOW, STREET, 90°, 8MM X 6MM	003648	Festo	153062
117	ADAPTER, 1/8NPT X 8MM	003651	Festo	153004
118	SHUTOFF VALVE, 8MM	004224	Festo	153476
119	ADAPTER, 1/8NPT X 6MM	003650	Festo	153002
120	TUBING, POLYETHYLENE, 6MM X 1MM, CLEAR	012048	Festo	543247
121	VALVE, CHECK, 6MM>6mm	017831	McMaster Carr	1866T112
123	TUBING, POLYETHYLENE, 8MM X 1.25MM, CLEAR	014817	Festo	543248
124	CHANNEL, RBR, 1/8 x 5/16	003128	McMaster Carr	8507K65
125	SPRING, EXT, 0.250 x 0.021 x 1.00	005991	Century Spring	5509
126	BUSHING, ST, NY, 11/64 x 1/2 x 1/2	006389	McMaster Carr	94639A534
127	BUSHING, ST, NY, 1/4 x 1/2 x 5/8	005986	McMaster Carr	94639A572
128	BUSHING, ST, NY, 1/4 x 5/8 x 1/16	005138	McMaster Carr	96371A202
129	BUSHING, ST, NY, 1/4 x 1/2 x 3/16	005985	McMaster Carr	94639A568
130	SPRING, DISC	005992	McMaster Carr	9716K62
131	GUARD, SWITCH, 1 x 1, 4-40	005139	McMaster Carr	1568A41

Section 7: Supplier Cross Reference

Supplier Chart (continued)

Item	Description	SEI Part #	Alternate Supplier	Supplier Part #
132	COLLAR, SHAFT, 1/8, SETSCREW	010877	McMaster Carr	9946K41
133	KNOB, ABS, 0.85 DIA, 1/8 SHAFT	001363	Newark in One	91F2243
134	WRENCH, HEX KEY, 1/8, T-HAND	003135	McMaster Carr	7041A13
135	WRENCH, HEX KEY, 2.5MM, T-HAND	003136	McMaster Carr	7041A42
138	FILTER, GLYCOL	006324	Festo	15889
139	FILTER, WATER	006236	Festo	160239
140	GASKET, FILLER NECK	006398	Shaw	910-0222-01
142	CAP, 6MM	003641	Festo	153263
200	SCREW, 10-32 x 1/4, SET, CUP, SS	000525	Fastenal	73245
201	SCREW, 6-32 x 7/8, SC, SS	000414	Fastenal	73417
202	SCREW, M3 x 10, SC, SS	000328	Fastenal	M82510010A40000
203	PIN, SPLIT, 3/16 x 1-1/4, SS	001739	Fastenal	74320
204	SCREW, 8-32 x 11/64, CAPTIVE, PH, SS	000523	McMaster-Carr	94350A145
205	SCREW, 6-32 x 3/4, MS, PNP, SS	000484	Fastenal	72388
206	SCREW, 8-32 x 3/8, FSC, SS	000442	Fastenal	73851
207	SCREW, 8-32 x 1/4, SET, CUP, SS, NYL	014125	McMaster-Carr	90251A190
209	SCREW, 8-32 x 1/2, SC, SS	000419	Fastenal	73422
210	PIN, SPLIT, 1/8 x 1-1/4, SS	001738	Fastenal	74311
211	SCREW, 6-32 x 3/16, MS, PNP, SS	000480	Fastenal	72500
212	SCREW, 10-24 x 3/8, BC, SS	000513	Fastenal	73731
213	BOLT, 1/4 x 3/4 x 10-32, SH, HX, SS	000557	McMaster Carr	94035A540
214	BOLT, 1/4 x 3/8 x 10-32, SH, HX, SS	000554	McMaster Carr	94035A535
215	SCREW, 10-32 x 3/8, SEAL, PNP, SS	000546	Fastenal	11104543
216	SCREW, 8-32 x 1/8, SET, CUP, SS	000363	Fastenal	73223
217	SCREW, 8-32 x 1, SC, SS	000423	Fastenal	73425
218	NUT, HX, NYL, 8-32, SS	001659	Fastenal	70856
219	SCREW, 8-32 x 1/2, FSC, SS	000444	Fastenal	73852
220	PIN, SPLIT, 1/8 x 1/4, SS	001735	Fastenal	171515
221	PIN, SPLIT, 1/8 x 1, SS	001737	Fastenal	74310
222	SCREW, 8-32 x 3/8, MS, PNP, SS	000487	Fastenal	72396
223	SCREW, 8-32 x 1, MS, PNP, SS	000489	Fastenal	72418
224	SCREW, 8-32 x 1-3/4, MS, PNP, SS	000490	Fastenal	72435
225	SCREW, 4-40 x 3/8, MS, PNP, SS	000475	Fastenal	72482
226	SCREW, 10-32 x 3/8, MS, PNP, SS	000545	Fastenal	72450
227	BOLT, 1/4 x 5/8 x 10-32, SH, HX, SS	000556	McMaster Carr	94035A539
228	NUT, HX, NYL, 10-32, SS	001685	Fastenal	70858

Section 7: Supplier Cross Reference

Supplier Chart (continued)

Item	Description	SEI Part #	Alternate Supplier	Supplier Part #
229	BOLT, 1/4 x 1/4 x 10-32, SH, HX, SS	000553	McMaster Carr	94035A534
230	NUT, CPL, 8-32 x 5/8, BR	001639	McMaster Carr	90308A640
231	SCREW, 8-32 x 1/4, MS, PNPH, SS	000486	Fastenal	72394
234	NUT, HX, NYL, 4-40, SS	001657	Fastenal	70854
235	SCREW, 1/4-20 x 1/2, BC, SS	000427	Fastenal	73459
236	NUT, KNUR, 10-24, BR	001638	McMaster Carr	92741A130
237	NUT, KNUR, 10-24, OX	001696	McMaster Carr	94775A021
238	BOLT, 3/8 x 1/2 x 1/4-20, SH, HX, SS	006411	McMaster Carr	94035A309
239	BUSHING, FL, BRZ, 3/8 x 1/2 x 5/16	005982		
240	WASHER, FLT, 3/8 x 3/4, BRZ	006412	McMaster Carr	5906K533
241	WASHER, FLT, 3/8 x 5/8, AN, SS	001869	McMaster Carr	RW4440020SS0000
242	WASHER, FLT, 1/4 x 5/8, SAE, SS	001819	Fastenal	0171977
243	NUT, HX, JAM, NYL, 1/4-20, SS	001663	Fastenal	0129156
244	NUT, HX, JAM, NYL, 10-32, SS	001686	Fastenal	0129155
245	SCREW, 8-32 x 1/4, SET, CUP, NYL, SS	014125	McMaster Carr	90251A176
246	SCREW, M4X0.7 X 50, SC, SS	017339	McMaster Carr	91292A140
247	SCREW, #10-32 X 1-3/4, SC, SS	017340	McMaster Carr	92196A278
301	STRAIN RELIEF, 1/2 MNPT	004863	McMaster Carr	69915K53
304	BATTERY, SLA, 12V x 0.8AH	000263	Powersonic	PS-1208
305	BOOT, TOGGLE SW, 1/4-40, BLK	001364	Digikey	360-1750-ND
306	BOOT, TOGGLE SW, M12, BLK	001365	Digikey	360-1606-ND
307	BOOT, TOGGLE SW, M12, RED	001366	Digikey	360-1707-ND
308	BOOT, TOGGLE SW, M12, YEL	001367	Digikey	360-1708-ND

Section 7: Supplier Cross Reference

Alternate Supplier Contacts

Century Spring Corp.
222 East 16th Street
Los Angeles, CA
90015
800-237-5225
www.centuryspring.com

Digi-Key Corporation
701 Brooks Ave. South
Thief River Falls, MN
56701
800-344-4539
www.digikey.com

Festo Corporation
502 Earth City Expressway, Suite 125
Earth City, MO
63045
800-993-3786
www.festo.com

McMaster Carr Supply Company
6100 Fulton Industrial Blvd. SW
Atlanta, GA
30336-2853
404-346-7000
www.mcmaster.com

McMaster Carr Supply Company
600 N County Line Rd.
Elmhurst, IL
60126-2081
630-833-0300
www.mcmaster.com

NAPA Auto Parts
National Chain of Stores
consult local yellow pages
www.napaonline.com

Power-Sonic Corporation
7550 Panasonic Way
San Diego, CA
92154
619-661-2020
www.power-sonic.com

Cords Canada Ltd.
62 Densley Avenue,
Toronto, ON
M6M 5E1
800-363-5080
www.cordscanada.com

Fastenal Industrial & Construction Supplies
National Chain of Stores
consult local yellow pages
www.fastenal.com

McMaster Carr Supply Company
200 New Canton Way
Robbinsville, NJ
08691-2343
609-689-3000
www.mcmaster.com

McMaster Carr Supply Company
200 Aurora Industrial Pkwy.
Aurora, OH
44202-8087
330-995-5500
www.mcmaster.com

McMaster Carr Supply Company
9630 Norwalk Blvd.
Santa Fe Springs, CA
90670-2932
562-692-5911
www.mcmaster.com

Newark In One
4801 N. Ravenswood
Chicago, IL
60640-4496
800-463-9275
www.newark.com

Stock Drive Products
2101 Jericho Tpke
New Hyde Park, NY
11042-5416
516-328-3300
www.sdp-si.com

Section 8: Warranty

Section 8: Warranty

SEI Industries Ltd. is an affiliate of Dart Aerospace:

- a) Limited Warranty on Products and Services can be found at <https://dartaerospace.com/pages/dart-warranty-return-policy>

THIS PAGE INTENTIONALLY LEFT BLANK

Appendix: Safety Data Sheet

1. Identification

Product identifier CAIROX® potassium permanganate

Other means of identification

SDS Number -

Recommended use Potassium Permanganate is an oxidant recommended for applications that require a strong oxidant.

Recommended restrictions Use in accordance with supplier's recommendations.



Manufacturer/Importer/Supplier/Distributor information

Company Name CARUS CORPORATION

Address 315 Fifth Street,
Peru, IL 61354, USA

Telephone 815 223-1500 - All other non-emergency inquiries about the product should be directed to the company

E-mail salesmkt@caruscorporation.com

Website www.caruscorporation.com

Contact Person Dr. Chithambarathanu Pillai

Emergency Telephone For Hazardous Materials [or Dangerous Goods] Incidents ONLY (spill, leak, fire, exposure or accident), call CHEMTREC at CHEMTREC®, USA: 001 (800) 424-9300
CHEMTREC®, Mexico (Toll-Free - must be dialed from within country): 01-800-681-9531
CHEMTREC®, Other countries: 001 (703) 527-3887

2. Hazard(s) Identification

Physical Hazards Oxidizing solids Category 2

Health Hazards Acute toxicity, oral Category 4
Skin corrosion/irritation Category 1B
Serious eye damage/eye irritation Category 1
Specific target organ toxicity, single exposure Category 1 (Respiratory System)
Specific target organ toxicity, repeated exposure Category 1 (Respiratory System, Central Nervous System)

Environmental Hazards Hazardous to the aquatic environment, acute hazard Category 1
Hazardous to the aquatic environment, long-term hazard Category 1

OSHA Defined Hazards Not classified.

Label Elements



Signal Word Danger

Hazard Statement May intensify fire; oxidizer. Harmful if swallowed. Causes severe skin burns and eye damage. Causes damage to organs (Respiratory System). Causes damage to organs (Respiratory System, Central Nervous System) through prolonged or repeated exposure. Very toxic to aquatic life with long lasting effects.

Precautionary Statement

Prevention Keep away from heat. Keep/Store away from clothing and other combustible materials. Take any precaution to avoid mixing with combustibles. Do not breathe dust. Wash thoroughly after handling. Wear protective gloves/protective clothing/eye protection/face protection. Do not eat, drink or smoke when using this product. Avoid release to the environment.

Appendix: Safety Data Sheet

Response	In case of fire: Use water for extinction. If swallowed: Rinse mouth. Do NOT induce vomiting. If on skin (or hair): Take off immediately all contaminated clothing. Rinse skin with water/shower. Wash contaminated clothing before reuse. If in eyes: Rinse cautiously with water for several minutes. Remove contact lenses, if present and easy to do. Continue rinsing. If inhaled: Remove person to fresh air and keep comfortable for breathing. Immediately call a poison center/doctor. If exposed: Call a poison center/doctor. Collect spillage.
Storage	Store locked up
Disposal	Dispose of contents/container in accordance with local/regional/national/international regulations.
Hazard(s) not otherwise classified (HNOC)	None known.

3. Composition / Information on Ingredients

Substances

Chemical Name	Common Name and Synonyms	CAS Number	%
Potassium Permanganate		7722-64-7	>97.5

Composition Comments All concentrations are in percent by weight unless ingredient is a gas. Gas concentrations are in percent by volume.

4. First-Aid Measures

Inhalation	Remove victim to fresh air and keep at rest in a position comfortable for breathing. For breathing difficulties, oxygen may be necessary. Get medical attention immediately.
Skin Contact	Take off immediately all contaminated clothing. Immediately flush skin with plenty of water. Get medical attention immediately. Wash contaminated clothing before reuse. Contact with skin may leave a brown stain of insoluble manganese dioxide. This can be easily removed by washing with a mixture of equal volume of household vinegar and 3% hydrogen peroxide, followed by washing with soap and water.
Eye Contact	Immediately flush with plenty of water for up to 15 minutes. Remove any contact lenses and open eyelids wide apart. Continue rinsing. Get medical attention immediately.
Ingestion	Immediately rinse mouth and drink plenty of water. Never give anything by mouth to a victim who is unconscious or is having convulsions. Do not induce vomiting. If vomiting occurs, keep head low so that stomach content doesn't get into the lungs. Get medical attention immediately.
Most important symptoms/effects, acute and delayed	Contact with this material will cause burns to the skin, eyes and mucous membranes. Permanent eye damage including blindness could result.
Indication of immediate medical attention and special treatment needed	Provide general supportive measures and treat symptomatically. In case of shortness of breath, give oxygen. Decomposition products are alkaline. Brown stain is insoluble manganese dioxide
General information	In the case of accident or if you feel unwell, seek medical advice immediately (show the label where possible). Ensure that medical personnel are aware of the material(s) involved, and take precautions to protect themselves. Show this safety data sheet to the doctor in attendance. For personal protection, see Section 8 of the SDS. Wash contaminated clothing before reuse.

Appendix: Safety Data Sheet

5. Fire-fighting measures

Suitable extinguishing media	Flood with water from a distance, water spray or fog.
Unsuitable extinguishing media	The following extinguishing media are ineffective: Dry chemical. Foam. Carbon dioxide (CO ₂). Halogenated materials.
Specific hazards arising from the chemical	May intensify fire; oxidizer. May ignite combustibles (wood, paper, oil, clothing, etc.). Contact with incompatible materials or heat (135 °C / 275 °F) could result in violent exothermic chemical reaction. Oxidizing agent, may cause spontaneous ignition of combustible materials. By heating and fire, corrosive vapors/gases may be formed.
Special protective equipment and precautions for firefighters	Self-contained breathing apparatus and full protective clothing must be worn in case of fire. Selection of respiratory protection for firefighting: follow the general fire precautions indicated in the workplace.
Fire-fighting equipment/instructions	Move container from fire area if it can be done without risk. Cool containers exposed to flames with water until well after the fire is out. Prevent runoff from fire control or dilution from entering streams, sewers, or drinking water supply. Dike fire control water for later disposal. Water runoff can cause environmental damage.
General fire hazards	The product is not flammable. May intensify fire; oxidizer. May ignite combustibles (wood, paper, oil, clothing, etc.). Contact with incompatible materials or heat (135 °C / 275 °F) could result in violent exothermic chemical reaction.

6. Accidental release measures

Personal precautions, protective equipment and emergency procedures	Keep unnecessary personnel away. Keep upwind. Do not touch damaged containers or spilled material unless wearing appropriate protective clothing. Avoid inhalation of vapors and contact with skin and eyes. Wear protective clothing as described in Section 8 of this safety data sheet. Local authorities should be advised if significant spillages cannot be contained
Methods and materials for containment and cleaning up	Keep combustibles (wood, paper, oil, etc.) away from spilled material. Should not be released into the environment. This product is miscible in water. Stop leak if possible without any risk. Dike the spilled material, where this is possible. Clean up spills immediately by sweeping or shoveling up the material. Do not return spilled material to the original container; transfer to a clean metal or plastic drum. To clean up potassium permanganate solutions, follow either of the following two options: Option # 1: Dilute to approximately 6% with water, and then reduce with sodium thiosulfate, a bisulfite or ferrous salt solution. The bisulfite or ferrous salt may require some dilute sulfuric acid (10% w/w) to promote reduction. Neutralize with sodium carbonate to neutral pH, if acid was used. Decant or filter and deposit sludge in approved landfill. Where permitted, the sludge may be drained into sewer with large quantities of water. Option # 2: Absorb with inert media like diatomaceous earth or inert floor dry, collect into a drum and dispose of properly. Do not use saw dust or other incompatible media. Disposal of all materials shall be in full and strict compliance with all federal, state, and local regulations pertaining to permanganates. To clean contaminated floors, flush with abundant quantities of water into sewer, if permitted by federal, state, and local regulations. If not, collect water and treat as described above. Never return spills in original containers for re-use. For waste disposal, see Section 13 of the SDS
Environmental precautions	Do not allow to enter drains, sewers or watercourses. Contact local authorities in case of spillage to drain/aquatic environment.

7. Handling and storage

Precautions for safe handling	Take any precaution to avoid mixing with combustibles. Do not get this material in your eyes, on your skin, or on your clothing. Do not breathe dust or mist or vapor of the solution. Use personal protection as recommended in Section 8 of the SDS. If clothing becomes contaminated, remove and wash off immediately. When using, do not eat, drink or smoke. Good personal hygiene is necessary. Wash hands and contaminated areas with water and soap before leaving the work site. Avoid release to the environment.
Conditions for safe storage, including any incompatibilities	Store locked up. Keep container tightly closed and in a well-ventilated place. Store in a cool, dry place. Store away from incompatible materials (See Section 10). Store in accordance with NFPA 430 requirements for Class II oxidizers.

Appendix: Safety Data Sheet

8. Exposure controls/personal protection

Occupational exposure limits

US. OSHA Table Z-1 Limits for Air Contaminants (29 CFR 1910.1000)

Components	Type	Value
Potassium permanganate (CAS 7722-64-7)	Ceiling	5 mg/m ³

US. ACGIH Threshold Limit Values

Material	Type	Value	Form
CAIROX® potassium permanganate	TWA	0.1 mg/m ³	Inhalable fraction
		0.02 mg/m ³	Respirable fraction

Components	Type	Value	Form
Potassium permanganate (CAS 7722-64-7)	TWA	0.1 mg/m ³	Inhalable fraction
		0.02 mg/m ³	Respirable fraction

US. NIOSH: Pocket Guide to Chemical Hazards

Material	Type	Value	Form
CAIROX® potassium permanganate	TWA	1 mg/m ³	Fume.

Components	Type	Value	Form
Potassium permanganate (CAS 7722-64-7)	STEL	3 mg/m ³	Fume.
	TWA	1 mg/m ³	Fume.

Biological limit values

No biological exposure limits noted for the ingredient(s).

Exposure guidelines

Follow standard monitoring procedures.

Appropriate engineering controls

Provide adequate general and local exhaust ventilation. An eye wash and safety shower must be available in the immediate work area.

Individual protection measures, such as personal protective equipment

Eye/face protection

Wear safety glasses with side shields (or goggles). Wear face shield if there is risk of splashes.

Skin protection

Hand protection

Wear chemical-resistant, impervious gloves. Use protective gloves made of: Rubber or plastic. Suitable gloves can be recommended by the glove supplier.

Other

Wear appropriate chemical resistant clothing. Rubber or plastic apron.

Respiratory protection

In case of inadequate ventilation or risk of inhalation of dust, use suitable respiratory equipment with particle filter. In the United States of America, if respirators are used, a program should be instituted to assure compliance with OSHA 29 CFR 1910.134.

Measurement Element: Manganese (Mn)

10 mg/m³

Any particulate respirator equipped with an N95, R95, or P95 filter (including N95, R95, and P95 filtering facepieces) except quarter-mask respirators. The following filters may also be used: N99, R99, P99, N100, R100 or P100.

Any supplied-air respirator.

25 mg/m³

Any supplied-air respirator operated in a continuous-flow mode.

Any powered, air-purifying respirator with a high-efficiency particulate filter.

50 mg/m³

Any air-purifying, full-face piece respirator equipped with an N100, R100, or P100 filter.

Any supplied-air respirator with a tight-fitting face piece that is operated in a continuous-flow mode.

Any powered, air-purifying respirator with a tight-fitting face piece and a high-efficiency particulate filter.

Any self-contained breathing apparatus with a full face piece.

Any supplied-air respirator with a full face piece.

Appendix: Safety Data Sheet

	500 mg/m ³ Any supplied-air respirator operated in a pressure-demand or other positive-pressure mode. Emergency or planned entry into unknown concentrations or IDLH conditions - Any self-contained breathing apparatus that has a full face piece and is operated in a pressure-demand or other positive-pressure mode.
	Escape Any air-purifying, full-face piece respirator equipped with an N100, R100, or P100 filter. Any appropriate escape-type, self-contained breathing apparatus.
Thermal hazards	Wear appropriate thermal protective clothing, when necessary.
General hygiene considerations	When using, do not eat, drink or smoke. Keep from contact with clothing and other combustible materials. Remove and wash contaminated clothing promptly. Wash hands before breaks and immediately after handling the product. Handle in accordance with good industrial hygiene and safety practice.

9. Physical and chemical properties

Appearance	Dark purple solid with metallic luster.
Physical state	Solid.
Form	Solid
Color	Dark purple.
Odor	Odorless.
Odor threshold	Not available.
pH	Not applicable.
Melting point/freezing point	Starts to decompose with evolution of oxygen (O ₂) at temperatures above 150 °C. Once initiated, the decomposition is exothermic and self-sustaining.
Initial boiling point and boiling range	Not applicable.
Flash point	Not applicable.
Evaporation rate	Not applicable.
Flammability (solid, gas)	Not applicable.
Upper/lower flammability or explosive limits	
Flammability limit - lower (%)	Not applicable.
Flammability limit - upper (%)	Not applicable.
Explosive limit - lower (%)	Not available.
Explosive limit - upper (%)	Not available.
Vapor pressure	< 0 kPa at 25 °C
Vapor density	Not applicable
Relative density	2.7 (20 °C) (Water = 1)
Solubility(ies)	
Solubility (water)	6 % (20 °C)
Partition coefficient (n-octanol/water)	Not available.
Auto-ignition temperature	Not available.
Decomposition temperature	464 °F (240 °C)
Viscosity	Not applicable.
Other information	
Density	2.70 g/cm ³
Explosive properties	Not explosive. Can explode in contact with sulfuric acid, peroxides and metal powders.
Molecular formula	H-Mn-O ₄ .K
Molecular weight	158.03 g/mol 158.03
Oxidizing properties	Strong oxidizing agent.

Appendix: Safety Data Sheet

10. Stability and reactivity

Reactivity	The product is stable and non-reactive under normal conditions of use, storage and transport.
Chemical stability	Stable at normal conditions.
Possibility of hazardous reactions	Contact with combustible material may cause fire. Can explode in contact with sulfuric acid, peroxides and metal powders. Starts to decompose with evolution of oxygen (O ₂) at temperatures above 150 °C. Once initiated, the decomposition is exothermic and self-sustaining.
Conditions to avoid	Contact with incompatible materials or heat (135 °C / 275 °F) could result in violent exothermic chemical reaction.
Incompatible materials	Acids. Peroxides. Reducing agents. Combustible material. Metal powders. Contact with hydrochloric acid liberates chlorine gas.
Hazardous decomposition products	By heating and fire, corrosive vapors/gases may be formed.

11. Toxicological information

Information on likely routes of exposure

Ingestion	Harmful if swallowed.
Inhalation	May cause irritation to the respiratory system.
Skin contact	Causes severe skin burns.
Eye contact	Causes serious eye damage.

Symptoms related to the physical, chemical and toxicological characteristics Contact with this material will cause burns to the skin, eyes and mucous membranes. Permanent eye damage including blindness could result.

Information on toxicological effects

Acute toxicity Harmful if swallowed.

Components	Species	Test Results
-------------------	----------------	---------------------

Potassium permanganate (CAS 7722-64-7)

Acute

Dermal

LD50	Rat	2000 mg/kg
------	-----	------------

Oral

LD50	Rat	2000 mg/kg
------	-----	------------

Skin corrosion/irritation Causes severe skin burns.

Serious eye damage/eye irritation Causes serious eye damage.

Respiratory or skin sensitization

Respiratory sensitization Not classified.

Skin sensitization Not classified.

Germ cell mutagenicity Not classified.

Carcinogenicity Not classified.

Reproductive toxicity Not classified.

Specific target organ toxicity - single exposure Causes damage to organs (respiratory system).

Specific target organ toxicity - repeated exposure Causes damage to organs (respiratory system, central nervous system) through prolonged or repeated exposure.

Aspiration hazard Not classified.

Chronic effects May cause damage to respiratory system. Prolonged exposure, usually over many years, to manganese oxide fume/dust can lead to chronic manganese poisoning, chiefly affecting the central nervous system

Appendix: Safety Data Sheet

12. Ecological information

Ecotoxicity Very toxic to aquatic life with long lasting effects.

Components	Species	Test Results
Potassium permanganate (CAS 7722-64-7)		
Aquatic		
Fish	LC50	
	Bluegill (<i>Lepomis macrochirus</i>)	2.7 mg/l, 96 hours, static 2.3 mg/l, 96 hours, flow through 2.3 mg/l, 96 hours 1.8 - 5.6 mg/l
	Carp (<i>Cyprinus carpio</i>)	3.16 - 3.77 mg/l, 96 hours 2.97 - 3.11 mg/l, 96 hours
	Goldfish (<i>Carassius auratus</i>)	3.3 - 3.93 mg/l, 96 hours, static
	Milkfish, salmon-herring (<i>Chanos chanos</i>)	> 1.4 mg/l, 96 hours
	Rainbow trout (<i>Oncorhynchus mykiss</i>)	1.8 mg/l, 96 hours 1.08 - 1.38 mg/l, 96 hours 0.77 - 1.27 mg/l, 96 hours
	Rainbow trout, donaldson trout (<i>Oncorhynchus mykiss</i>)	0.275 - 0.339 mg/l, 96 hours

Persistence and degradability Expected to be readily converted by oxidizable materials to insoluble manganese oxide.

Bioaccumulative potential Potential to bioaccumulate is low.

Mobility in soil The product is miscible with water. May spread in water systems.

Other adverse effects None known.

13. Disposal considerations

Disposal instructions Dispose of contents/container in accordance with local/regional/national/international regulations.

Hazardous waste code D001: Ignitable waste
The Waste code should be assigned in discussion between the user, the producer and the waste disposal company.

Waste from residues / unused products Do not allow this material to drain into sewers/water supplies.

Contaminated packaging Since emptied containers may retain product residue, follow label warnings even after container is emptied. Rinse container at least three times to an absence of pink color before disposing. Empty containers should be taken to an approved waste handling site for recycling or disposal.

14. Transport Information

DOT

UN number	UN1490
UN proper shipping name	Potassium permanganate
Transport hazard class(es)	
Class	5.1
Subsidiary risk	-
Packing Group	II
Environmental hazards	
Marine pollutant	Yes
Special precautions for user	Read safety instructions, SDS and emergency procedures before handling.
Special provisions	IB8, IP2, IP4, T3, TP33
Packaging exceptions	152
Packaging non bulk	212
Packaging bulk	240

Appendix: Safety Data Sheet

IATA

UN number	UN1490
UN proper shipping name	Potassium permanganate
Transport hazard class(es)	
Class	5.1
Subsidiary risk	-
Label(s)	5.1
Packing Group	II
Environmental hazards	Yes
ERF Code	5L
Special precautions for user	Read safety instructions, SDS and emergency procedures before handling.

IMDG

UN number	UN1490
UN proper shipping name	POTASSIUM PERMANGANATE
Transport hazard class(es)	
Class	5.1
Subsidiary risk	-
Label(s)	5.1
Packing Group	II
Environmental hazards	
Marine pollutant	Yes
EmS	F-H, S-Q
Special precautions for user	Read safety instructions, SDS and emergency procedures before handling.

Transport in bulk according to Annex II of MARPOL 73/78 and the IBC Code Not applicable.

15. Regulatory Information

US federal regulations This product is a "Hazardous Chemical" as defined by the OSHA Hazard Communication Standard, 29 CFR 1910.1200.
All components are on the U.S. EPA TSCA Inventory List.

Drug Enforcement Administration (DEA) (21 CFR 1310.02 (b) 8: List II chemical.

Department of Homeland Security (DHS) Chemical Facility Anti-Terrorism Standards (6 CFR 27, Appendix A): Listed.

TSCA Section 12(b) Export Notification (40 CFR 707, Subpt. D)

Not regulated

US. OSHA Specifically Regulated Substances (29 CFR 1910.1001-1050)

Not listed

CERCLA Hazardous Substance List (40 CFR 302.4)

Potassium permanganate (CAS 7722-64-7) LISTED

Superfund Amendments and Reauthorization Act of 1986 (SARA)

Hazard categories Immediate Hazard - Yes
Delayed Hazard - Yes
Fire Hazard - Yes
Pressure Hazard - No
Reactivity Hazard - No

SARA 302 Extremely hazardous substance

Not listed.

SARA 302 Extremely hazardous substance

Not listed.

Appendix: Safety Data Sheet

SARA 311/312 Hazardous chemical

Yes

SARA 313 (TRI reporting)

Chemical name	CAS number	% by wt.
Potassium permanganate	7722-64-7	> 97.5

Other federal regulations

Clean Air Act (CAA) Section 112 Hazardous Air Pollutants (HAPs) List

Potassium permanganate (CAS 7722-64-7)

Clean Air Act (CAA) Section 112(r) Accidental Release Prevention (40 CFR 68.130)

Not regulated.

Clean Water Act (CWA) Section 112(r) (40 CFR 68.130)

Hazardous substance

Safe Drinking Water Act (SDWA)

Not regulated.

Drug Enforcement Administration (DEA). List 2, Essential Chemicals (21 CFR 1310.02(b) and 1310.04(f)(2) and Chemical Code Number

Potassium permanganate (CAS 7722-64-7) 6579

Drug Enforcement Administration (DEA). List 1 & 2 Exempt Chemical Mixtures (21 CFR 1310.12(c))

Potassium permanganate (CAS 7722-64-7) 15 % wt

DEA Exempt Chemical Mixtures Code Number

Potassium permanganate (CAS 7722-64-7) 6579

US state regulations

US. Massachusetts RTK - Substance List

Potassium permanganate (CAS 7722-64-7)

US. New Jersey Worker and Community Right-to-Know Act

Potassium permanganate (CAS 7722-64-7)

US. Pennsylvania Worker and Community Right-to-Know Law

Potassium permanganate (CAS 7722-64-7)

US. Rhode Island RTK

Potassium permanganate (CAS 7722-64-7)

US - California Proposition 65 - Carcinogens & Reproductive Toxicity (CRT): Listed substance

Not listed.

US - California OSH Hazardous Substance List

Listed.

This product does not contain a chemical known to the State of California to cause cancer, birth defects or other reproductive harm.

International Inventories

Country(s) or region	Inventory name	On inventory (yes/no)*
Australia	Australian Inventory of Chemical Substances (AICS)	Yes
Canada	Domestic Substances List (DSL)	Yes
Canada	Non-Domestic Substances List (NDSL)	No
China	Inventory of Existing Chemical Substances in China (IECSC)	Yes
Europe	European Inventory of Existing Commercial Chemical Substances (EINECS)	Yes
Europe	European List of Notified Chemical Substances (ELINCS)	No
Japan	Inventory of Existing and New Chemical Substances (ENCS)	Yes
Korea	Existing Chemicals List (ECL)	Yes
New Zealand	New Zealand Inventory	Yes
Philippines	Philippine Inventory of Chemicals and Chemical Substances (PICCS)	Yes
United States & Puerto Rico	Toxic Substances Control Act (TSCA) Inventory	Yes

Appendix: Safety Data Sheet

* "Yes" indicates this product complies with the inventory requirements administered by the governing country(s).
"No" indicates that one or more components of the product are not listed or exempt from listing on the inventory administered by the governing country(s).

16. Other information, including date of preparation or last revision

Issue date 27-November-2013
Revision date 23-April-2014
Version # 02
Further information HMIS® is a registered trade and service mark of the NPCA.
NFPA Ratings



List of abbreviations GHS: Globally Harmonized System of Classification and Labeling of hazardous properties of Chemicals.
TWA: Time weighted average.
LD50: Lethal Dose, 50%.
LC50: Lethal Concentration, 50%.
IMDG: International Maritime Dangerous Goods.
IATA: International Air Transport Association.
MARPOL: International Convention for the Prevention of Pollution from Ships.

References HSDB® - Hazardous Substances Data Bank
Registry of Toxic Effects of Chemical Substances (RTECS)
IARC Monographs. Overall Evaluation of Carcinogenicity
National Toxicology Program (NTP) Report on Carcinogens
ACGIH Documentation of the Threshold Limit Values and Biological Exposure Indices

Disclaimer The information contained herein is accurate to the best of our knowledge. However, data, safety standards and government regulations are subject to change and, therefore, holders and users should satisfy themselves that they are aware of all current data and regulations relevant to their particular use of product. CARUS CORPORATION DISCLAIMS ALL LIABILITY FOR RELIANCE ON THE COMPLETENESS OR ACCURACY OR THE INFORMATION INCLUDED HEREIN. CARUS CORPORATION MAKES NO WARRANTY, EITHER EXPRESS OR IMPLIED, INCLUDING, BUT NOT LIMITED TO, ANY WARRANTIES OF MERCHANTABILITY OR FITNESS FOR PARTICULAR USE OR PURPOSE OF THE PRODUCT DESCRIBED HEREIN. All conditions relating to storage, handling, and use of the product are beyond the control of Carus Corporation, and shall be the sole responsibility of the holder or user of the product.

CAIROX® is a registered trademark of Carus Corporation. Copyright 1998

This SDS contains revisions in the following section(s): This safety data sheet contains revisions in the following section(s):