



# **SACKSAFOAM BLADDER**

## **OPERATIONS MANUAL**

### **2024B**

**SACKSAFOAM BLADDER MANUAL**  
**Version 2024B**  
**Part Number 002260**

**PLEASE READ BEFORE USING.**

**This manual is applicable to the following models:**

8018 (# 004338)  
2044 (# 004339)

Physical copies of this manual (# 002260) are available from SEI.

The manual is available on the SEI website.

Register for manual update notifications at [bambiupdate@sei-ind.com](mailto:bambiupdate@sei-ind.com)

This manual is based on information that was available at the time it was printed and may not be applicable to products received before the issue date and customized items.

**SEI INDUSTRIES LTD.**

7400 Wilson Avenue  
Delta, B.C. Canada  
V4G 1H3

Phone: (604) 946-3131

Fax: (604) 940-9566

E-Mail: [seisales@sei-ind.com](mailto:seisales@sei-ind.com)

Website: [www.bambibucket.com](http://www.bambibucket.com)

# Revision Summary

Version	Release Date	Revision Description	Pages	App.
2019A	19-Jan-2019	<ul style="list-style-type: none"><li>• General Revision</li></ul>	-	AW
2024A	08-Feb-2024	<ul style="list-style-type: none"><li>• Changed plugs to NEMA 6</li></ul>	36,37	MDT
2024B	19-Jun-2024	<ul style="list-style-type: none"><li>• Change from SFC to Bambi Controller</li><li>• Removed model 5550 (004340)</li></ul>	13-15 30 21	MDT

# Table of Contents

<b>Section 1: Introduction</b> .....	<b>1</b>
Overview .....	1
<b>Section 2: Installation</b> .....	<b>3</b>
Installation Procedure .....	3
<b>Section 3: Controller</b> .....	<b>7</b>
Overview .....	7
Rear Connections .....	7
Front Controls .....	8
Wiring the Controller .....	9
Controller Setup .....	10
Long Lines .....	11
<b>Section 4: Preflight Safety Checklist</b> .....	<b>13</b>
Safety Checklist .....	13
<b>Section 5: Operations</b> .....	<b>15</b>
Filling the Bladder .....	15
Using the Controller .....	16
<b>Section 6: Troubleshooting</b> .....	<b>19</b>
Troubleshooting Chart .....	19
<b>Section 7: Maintenance</b> .....	<b>21</b>
Maintenance Procedures .....	21
<b>Section 8: Specifications and Parts</b> .....	<b>23</b>
Capacity and Weight Specifications .....	23
Parts .....	26
<b>Section 9: Drawings</b> .....	<b>35</b>
<b>Section 10: Warranty</b> .....	<b>37</b>



# Section 1: Introduction

This manual provides helicopter operators with important information on the operation and maintenance of the Sacksafoam Bladder foam dispensing system for use with the Bambi and Bambi MAX Bucket.

Please read this manual prior to flying the bucket, particularly the sections on installation, filling, and dispensing. For your own protection and for longer system life, always heed the instructions and warnings. Ignoring these warnings could result in personal injury, bucket damage, Sacksafoam damage, or aircraft damage.

## Overview

Sacksafoam is a foam injection system that uses a pump to dispense a controlled amount of foam concentrate from a reservoir into the water in the bucket. The operation of the Sacksafoam is controlled by the pilot through a control unit, which is mounted in the cockpit.

The Sacksafoam Bladder has several advanced features to enhance the efficiency of helicopter firefighting:

- The bladder containing the foam concentrate mounts inside the bucket. This eliminates spillage and possible corrosion damage associated with carrying foam concentrate inside the helicopter. An internal check valve stops water from flowing into the bladder and ensures that foam is dispensed only while the injection pump is operating. Because the foam in the bladder displaces the water in the Bambi Bucket, the total payload is always constant.
- An optional foam transfer pump for easily filling the Sacksafoam Bladder is available from SEI Industries. This portable pump greatly facilitates the filling of the Sacksafoam Bladder and is powered by 24 volts DC, either from the aircraft or from an auxiliary power source.
- The operation of the Sacksafoam Bladder can be quickly mastered by users with no prior experience. Several dumps with foam will provide familiarity with the use of the system.

SEI offers complete parts supply and repair facilities for the Sacksafoam Bladder. For maintenance and repair purposes, parts diagrams and descriptions are provided in *Section 8: Specifications and Parts*. When ordering parts, please provide the model information which is silk-screened on the bladder.

Additional copies of this manual are also available from SEI Industries Ltd. or by visiting our website at [www.bambibucket.com](http://www.bambibucket.com) for more information on these products. An online version of this manual is also available at this website.

**THIS PAGE INTENTIONALLY LEFT BLANK**

## Section 2: Installation

### Installation Procedure

#### NOTICE

If the Bambi Bucket cinch strap hook is on the ballast side of the bucket, it must be rotated 180 degrees to the opposite side, to allow cinch adjustment once the bladder is installed.

To install the bladder:

1. Release the bottom end of the ballast side IDS restrainer cable by removing the clevis pin from the restrainer bracket inside the bucket.



2. If you do not wish to permanently replace the IDS restrainer cable with the Sacksafoam restrainer strap, tie the restrainer cable out of the way where it will not interfere with bucket operation. Otherwise cut off the IDS restrainer cable.



3. Attach one end of the chain to the 1/4" shackle and attach the shackle to the IDS hub. Determine the length of chain by matching the total length of the assembly to the IDS restrainer cable. Insert the quick link into the determined chain length and insert the quick link into the D-ring at the end of the webbing strap and secure.





## Section 2: Installation

4. Connect the lower end of the restrainer strap to the restrainer bracket, reinstalling the clevis pin. Use a new cotter pin to secure the clevis pin to the restrainer bracket.



5. The installation should now look as shown.



6. Disconnect the bottom end of the IDS restrainer cable, opposite the ballast, by removing the clevis pin from the restrainer bracket. Attach the supplied shackle and length of chain to the IDS restrainer cable and re-connect it to the bracket. If the IDS cable already has a chain fitted, extend it to its longest length.



7. Attach hanger assemblies to the top of bladder.



## Section 2: Installation

8. Fold up the bladder and slide it in between the spokes and into the bucket. For smaller buckets, remove one spoke at the shell end. The bladder should be centered on the ballast pouch. The IDS restrainer strap attached, in steps 3 and 4, should pass around the bottom of the bladder.



### CAUTION

Do not remove the Bambi Bucket's ballast pouch when fitting the bladder. This could cause unpredictable flight characteristics.

9. Install the shackles onto the webbing suspension straps at the bucket rim to line up with the spring links on the bladder. Chain links are supplied with the hanger assemblies if the bladder is out of alignment.



10. Straighten out the bladder so that it sits straight inside the bucket.

11. Connect the control cable to the waterproof connector on the bladder. Ensure that the white waterproofing washer is installed inside the receptacle.



## Section 2: Installation

12. Install the breakaway connector in the control cable, near the Bambi control head.



13. Secure the control cable to one of the Bambi suspension cables using the tie wraps provided. The connector may be taped together to prevent premature release.



### CAUTION

IDS restrainer cable and strap adjustments are required to keep the IDS hub as flat as possible throughout its vertical range of travel. If improperly adjusted, the IDS hub will not sit level when the bucket is empty.

This is due to the deformation of the Bambi Bucket shell, caused by the weight of the Sacksafoam. Improper adjustment may result in fouling of the trip line pulley on the IDS hub (small series) and/or severe damage to the entire IDS (all models).

## Section 3: Controller

### Overview

The Bambi Controller is intended for use with Bambi and Bambi MAX Buckets. It is installed into an aircraft console in accordance with MS-25212 (DZUS mounting rails).

### Rear Connections

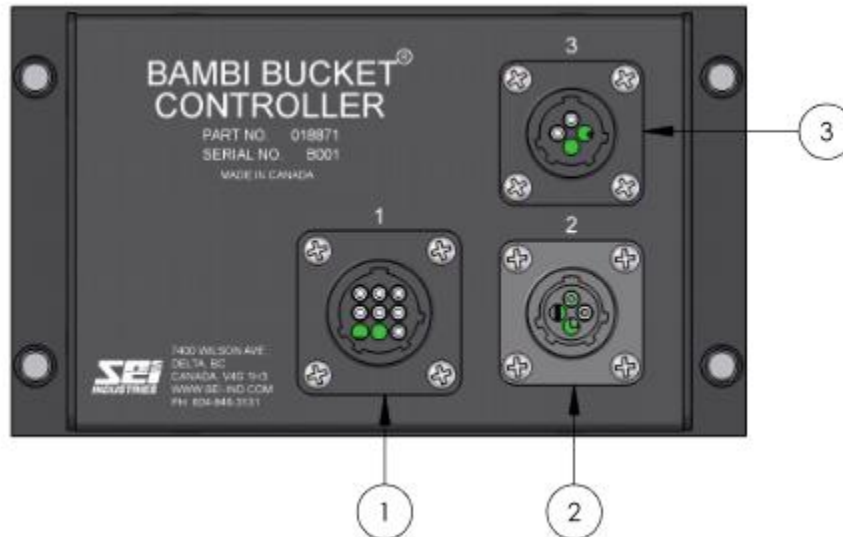

#### 1. Main Connector

Connects to power, external input signals, bucket valve, and foam injection pump. See Section 5: Drawings for pinout details.

#### 2. Load Sense Head Connector

Connects to a load sensing head when installed.

#### 3. GPS Connector

Connects to an external GPS receiver when installed.

### Front Controls

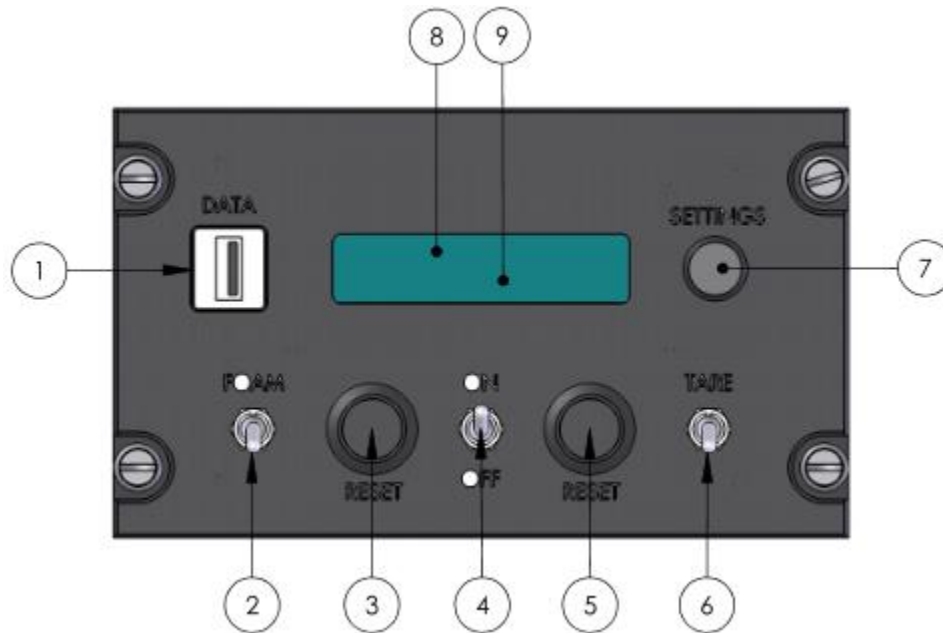

#### 1. DATA Port

Install a USB flash drive in the **DATA** port to store operational data.

#### 2. FOAM Switch

Momentarily actuate the **FOAM** toggle switch to start the foam concentrate injection process.

#### 3. RESET Button - Left

Press the **RESET** button to reset the lefthand foam counter.

Press and hold the **RESET** button to reset the lefthand bucket counter.

#### 4. Power Switch

Actuate the power switch to turn the controller **ON** and **OFF**. In the **OFF** position, the valve signal is passed directly through the controller, bypassing the electronics.

#### 5. RESET Button - Right

Press the **RESET** button to reset the righthand foam counter.

Press and hold the **RESET** button to reset the righthand bucket counter.

## Section 3: Controller

---

### 6. TARE Switch

Momentarily actuate the **TARE** toggle switch to increment the bucket count.

### 7. SETTINGS Knob

Press the **SETTINGS** knob to enter, select, and exit the menu system. Rotate the knob to change menu items.

### 8. Display Upper

The upper line of the display indicates the bucket counters (e.g. “655 BUCKET 321”).

The upper line of the display indicates the current menu item when in the menu system. (e.g. “BUCKET CAPACITY”).

The upper line of the display will indicate that foam is being injected when the foam injection pump is operating (e.g. “INJECT FOAM 0.7%”).

### 9. Display Lower

The lower line of the display indicates the foam counters (e.g. “058 FOAM 007”).

The lower line of the display indicates the current menu option when in the menu system. (e.g. “HL9800 2600 USG”).

## Wiring the Controller

A wiring diagram for the controller is provided in Section 9: Drawings

### **Power (J1 pins 1 & 2)**

The controller requires a power supply of 24-28 VDC. It requires a 10 A circuit breaker.

### **External Foam Trigger (J1 pin 3)**

The foam injection may be initiated by an external trigger switch. The switch can be either sourcing (switching +28VDC) or sinking (switching to ground). The controller will automatically detect how the external switch is configured. This is not required if not using the foam controller functionality.

### **Foam Pump (J1 pins 4 & 6)**

The controller supplies the switched power to the foam injection pump.

## Section 3: Controller

---

### Controller Setup

It will be necessary to adjust some of the controller settings to suit the user's particular installation. Once saved, these settings will be the default settings the next time the unit is powered on.

The settings are changed by accessing the menu system. Depending on the user's selection of options, some other menu items may not display.

#### ***Units of Measurement***

The controller can be set to operate using US Gallons or Liters:

- Press the **SETTINGS** knob to enter the menu system.
- Rotate the **SETTINGS** knob until "UNITS" is displayed in the upper line of the display.
- Press the **SETTINGS** knob to enter the **UNITS** menu item.
- Rotate the **SETTINGS** knob to select the units in the lower line of the display.
- Press the **SETTINGS** knob to save and exit the menu system.

#### ***Bucket Model / Capacity***

The controller displays both the bucket model number and bucket capacity in the user's selected units.

- Press the **SETTINGS** knob to enter the menu system.
- Rotate the **SETTINGS** knob until "BUCKET CAPACITY" is displayed in the upper line of the display.
- Press the **SETTINGS** knob to enter the **BUCKET CAPACITY** menu item.
- Rotate the **SETTINGS** knob to select the bucket model / capacity in the lower line of the display.
- Press the **SETTINGS** knob to save and exit the menu system.

#### ***Valve Type***

Selecting the valve type disables any features that are not available with the user's valve and removes the features from the menu system to reduce clutter.

- Press the **SETTINGS** knob to enter the menu system.
- Rotate the **SETTINGS** knob until "VALVE TYPE" is displayed in the upper line of the display.
- Press the **SETTINGS** knob to enter the **VALVE TYPE** menu item.
- Rotate the **SETTINGS** knob to select the valve type in the lower line of the display.
- Press the **SETTINGS** knob to save and exit the menu system.

## Section 3: Controller

---

### ***Foam Reservoir Capacity***

The controller displays the foam concentrate reservoir capacity in the user selected units.

- Press the **SETTINGS** knob to enter the menu system.
- Rotate the **SETTINGS** knob until “**FOAM RESERVOIR**” is displayed in the upper line of the display.
- Press the **SETTINGS** knob to enter the **FOAM RESERVOIR** menu item.
- Rotate the **SETTINGS** knob to select the reservoir capacity in the lower line of the display. Selecting “**NONE**” disables the foam controller function.
- Press the **SETTINGS** knob to save and exit the menu system.

### ***Display Backlight***

The display backlight can be adjusted to suit ambient lighting conditions.

- Press the **SETTINGS** knob to enter the menu system.
- Rotate the **SETTINGS** knob until “**BACKLIGHT**” is displayed in the upper line of the display.
- Press the **SETTINGS** knob to enter the **BACKLIGHT** menu item.
- Rotate the **SETTINGS** knob to adjust the backlight brightness in the lower line of the display.
- Press the **SETTINGS** knob to save and exit the menu system.

## Long Lines

The supplied control cable connecting the control box and bladder, fits Bambi Buckets with standard length suspension lines. The cable is sized to provide 24V to the injection pump when 28V is supplied to the control box. If the Bambi Bucket is suspended from the helicopter with an additional long line, the standard control cable may not be long enough.

See the following chart for recommended longline wire sizes for the Sacksafoam Bladder.

Wire Length		Wire Type	Connectors	
Feet	Meters		Top	Bottom
0–100	0–30	14/2 SOW	NEMA 6-15P	NEMA 6-15R
100–200	30–61	12/2 SOW	NEMA 6-15P	NEMA 6-15R

### ***Wire Specifications***

Control cables supplied with the Sacksafoam Bladder unit meet Mil-C-27500 specifications. Individual hook-up wires meet Mil-W-22759/16 specifications. It is recommended that any replacement wire or cable meet these specifications. Extra cable and wire are available from SEI Industries Ltd.



**THIS PAGE INTENTIONALLY LEFT BLANK**

# Section 4: Preflight Safety Checklist

## Safety Checklist

Along with the aircraft, the Bambi Bucket and Sacksafoam system should also receive a preflight inspection each day. Follow the checklist below, beginning at the bottom of the bucket and working upwards.

1. Are all the attachments connecting the bladder to the Bambi Bucket firmly secured?
2. Is the wiring connector (close to the bladder) tightly secured? Does it have the white waterproofing washer installed inside the receptacle?
3. Is the power cable leading to the bladder secured to one of the Bambi Bucket suspension lines?
4. Is there a breakaway plug installed in the power cable near the cargo hook? Is it taped together to prevent premature release?
5. Is the control box operating properly? (Cap the outlet port on the bladder to avoid dispensing foam when testing the control box.)
6. Are the wires in the helicopter secured to avoid tripping and tangling?
7. Prior to take off, ensure that the cam lock cap on the foam outlet port is removed.

Refer to the Bambi Bucket manual for the preflight check on the Bambi Bucket itself.

## Section 4: Preflight Safety Checklist

---

THIS PAGE INTENTIONALLY LEFT BLANK

## Section 5: Operations

### Filling the Bladder

1. If any adjustment of the Bambi Bucket cinch strap is required, it should be made prior to the filling of the bladder, if possible. Adjusting the cinch strap is difficult when the bladder is full of foam.

#### NOTICE

The volume of the bladder should be reduced 20% for every 10% reduction in Bambi Bucket volume.

2. Remove the cam lock plug from the fill port.
3. Pour or pump in foam concentrate.



#### CAUTION

Overfilling the bladder with the Bambi Bucket cinched down may cause the dump valve to jam.

4. All air trapped in the bladder must be removed, otherwise the Bambi Bucket may not sink when dipped in the water. If the bladder is lying on the ground, excess air can be removed by opening the vents on each side and pressing down in the centre of the bladder. Close the vents tightly after exhausting all the air.



5. Replace the cam lock filler plug.

## Section 5: Operations

6. Remove the cam lock cap from the foam outlet port. An internal check valve ensures foam is dispensed only while the injection pump is operating.



### ***Removing the Bladder from the Bucket***

1. Reverse installation sequence.
2. If there is any appreciable amount of foam left in the bladder, it should be pumped out until the pump runs dry. At this point the bladder can be easily removed from the bucket. The remaining foam (approximately four litres with the 8018bladder) can be removed through the drain port.
3. The bladder should be flushed with fresh water and pumped out. This will also clean the pump. Drain any residual water through the drain port.
4. Clean off the outside of the bladder to remove any foam residue.

### **NOTICE**

Proper cleaning of the bladder prior to storage will increase the life span of the unit.

## Using the Controller

### ***Turning on the Controller***

- Actuate the **ON/OFF** toggle switch to the **ON** position.

### ***Setting Foam Percentage***

The foam mix ratio is adjustable between 0.1% and 1.5% in 0.1% increments.

- Press the **SETTINGS** knob to enter the menu system.
- Rotate the **SETTINGS** knob until “**FOAM CONTROL**” is displayed in the upper line of the display.
- Press the **SETTINGS** knob to enter the **FOAM CONTROL** menu item.
- Rotate the **SETTINGS** knob to select the mix ratio in the lower display line.
- Press the **SETTINGS** knob to save and exit the menu system.

## Section 5: Operations

---

### *Initiating Foam Injection*

Foam injection can be initiated by either:

- Momentarily actuating the “**FOAM**” toggle switch, or
- Using an external input signal

While the injection pump is operating, the lower line of the display will indicate the selected foam mix ratio (e.g. “**INJECT FOAM 0.7%**”).

### *Counting Foam Drops*

The controller has two counters for automatically counting the foam drops. Every time a foam pump injection cycle is completed, the foam counters will automatically increment. The values of the current foam counts are displayed in the lower line of the display (e.g. “**058 FOAM 007**”).

Each counter can be independently reset by pressing the “**RESET**” button located below the counter. The values of these counters are maintained in memory when the controller is powered off.

### *Counting Bucket Drops*

The controller also has two counters for manually counting bucket drops. To increment the counts, momentarily actuate the “**TARE**” toggle switch. The values of the current bucket counts are displayed in the upper line of the display (e.g. “**362 BUCKET 436**”).

Each counter can be independently reset by pressing and holding the “**RESET**” button located below the counter. The values of these counters are maintained in memory when the controller is powered off.

**THIS PAGE INTENTIONALLY LEFT BLANK**

## Section 6: Troubleshooting

### Troubleshooting Chart

Problem	Possible Cause	Solution
Foam control menu not displayed	Incorrect foam reservoir selected	FOAM RESERVOIR ≠ NONE
Incorrect foam concentration	Incorrect foam reservoir selected	Select correct foam reservoir size
	Incorrect bucket capacity selected	Select correct bucket capacity
	Pump connected backwards	Check pump output by pumping into bucket.
Counter display menu not displayed	Load sense head disabled	LOAD SENSE HEAD = YES
Bucket counts not resetting	Failure to hold the <b>RESET</b> button long enough	Press and hold the <b>RESET</b> button for at least 3 seconds
Display not visible	Polarized sunglasses	Rotate glasses
Pump fails to operate	Blown breaker	Check helicopter breaker and breaker on back of control box
	Bad connection	Using a multimeter, check that current is reaching control box and bladder.  Check contacts and waterproof connector.
Bambi Bucket dump valve not working	Bladder fouling valve	Reduce amount of foam in bladder until it clears valve.
	IDS hub tipping and fouling trip line	Adjust IDS restrainers so that hub sits level.



**THIS PAGE INTENTIONALLY LEFT BLANK**

# Section 7: Maintenance

## Maintenance Procedures

The Sacksafoam Bladder unit requires no maintenance other than cleaning. Daily, after use, and prior to storage, the bladder should be flushed out with clean water. Clean off the outside of the bladder to remove any residual foam.

### NOTICE

Proper cleaning of the bladder prior to storage will increase the life span of the unit.

### *Flushing Procedure*

1. Insert a water hose into the fill port and run the dispenser pump until the water runs clean.
2. Wash out the side of the bladder until clean.
3. Remove the drip tube to drain any residual foam.

### CAUTION

Residual foam will form a waxy substance that can prevent proper operation of the Sacksafoam.

### *Pump Maintenance*

Check wires and connectors periodically to be sure corrosion is not adding additional resistance to the motor circuit and causing a low voltage condition at the motor. Low voltage can inhibit the motor from starting and can cause a fuse to blow. Full voltage should be available to prevent motor damage. At the end of each fire season, the pump should be flushed with clean water as foam will dry out over time causing the impeller to stick. Some water can remain in the pump while in storage. Also, if the pump is idle for long periods of time, the impeller may stick to the pump body, preventing motor rotation and causing blown fuses. To correct, remove the end cover and the impeller, clean the body and impeller, then lubricate with water or a small amount of grease before re-assembly.

If the pump is stored in freezing temperatures, drain it by loosening the end cover screws, allowing any foam or water to drain completely. A service kit or spare impellers should be carried onboard to be assured of pumping capability. Spares kits are supplied with each pump and additional kits can be ordered from SEI (see parts list).

**THIS PAGE INTENTIONALLY LEFT BLANK**

## Section 8: Specifications and Parts

### Capacity and Weight Specifications

Capacities and weights are accurate to within 5%. Specifications are subject to change.

#### Sacksafoam Models

Bucket Model	Model	Bladder Capacity		Current @ 28VDC	Empty Weight		Gross Weight	
		US Gal	Litres		lb	kg	lb	kg
BB8096	8018	12	45	5 AMPS	14	6	113	51
BB9011								
BB1012								
BB1214								
BB1518								
BB1821								
BB2024	2044	30	114		17	8	268	122
BB2226								
BB2732								
BB3542								
BB4453								

## Section 8: Specifications and Parts

### Controller

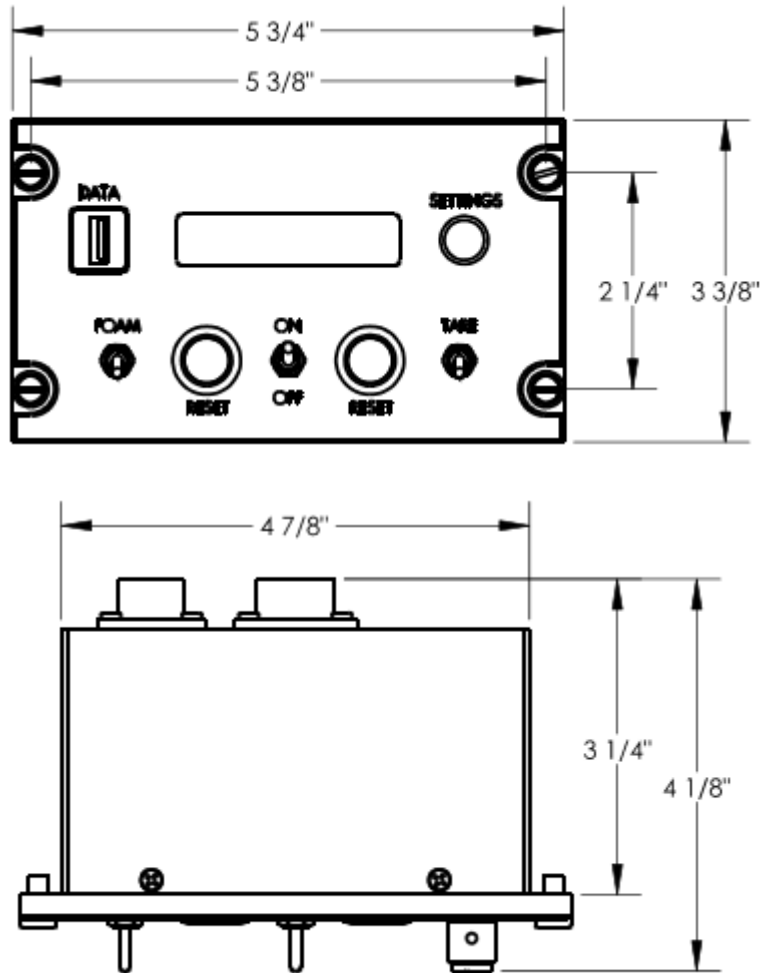

Controller Weight:	1.3 lb (600 grams)
Voltage:	24-28 VDC
Current:	7A
Circuit Breaker:	10A

## Section 8: Specifications and Parts

### Control Box 9 Pin Connector Configuration

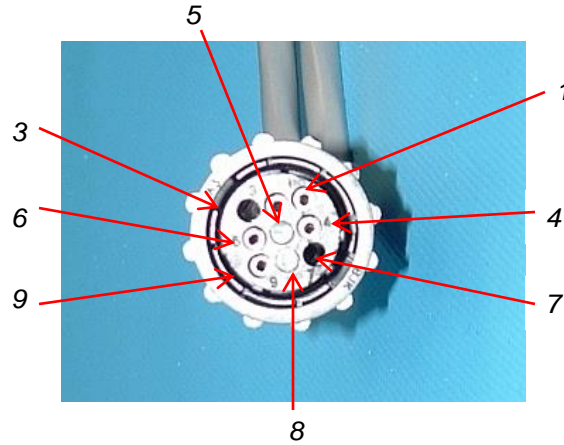

PIN	DESCRIPTION	WIRE COLOR
1	+ 24VDC supply	Red
2	- 24VDC supply	Black
3		
4	+ 24VDC to foam dispense pump	White
5		
6	- 24VDC to foam dispense pump	White / Blue
7		
8		
9	+ 24VDC from Bambi dump button	Green

Parts

Bladder Assembly\*

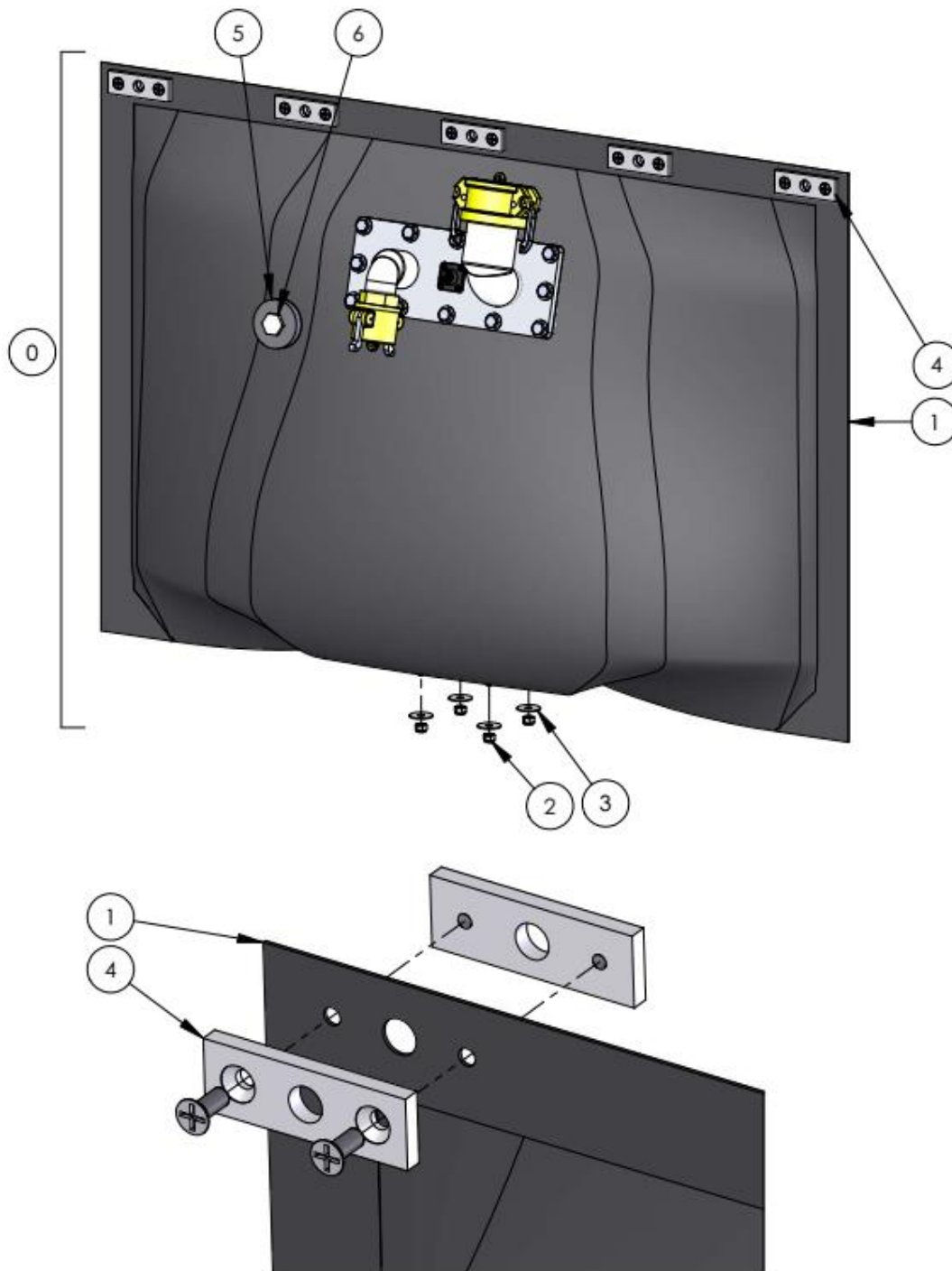

*\*Not an accurate representation of all models.*

## Section 8: Specifications and Parts

### *Bladder Assembly (continued)*

ITEM	MODEL	PART #	DESCRIPTION	QTY
0	8018	004355	BLADDER, 12USG, ASSY	1
	2044	004358	BLADDER, 30USG, ASSY	
	5550	004360	BLADDER, 72USG, ASSY	
1	8018	004353	BLADDER, 12USG	1
	2044	002399	BLADDER, 30USG	
	5550	004359	BLADDER, 72USG	
2	ALL	001662	NUT, HX, NYL, 1/4-20, SS	4
3		001858	WASHER, FLAT, 1/4 x 1, FND, SS	4
4	8018	004361	PLATE, REINFORCING, ASSY	5
	2044			7
	5550			
5	8018	002695	FLANGE, BLKHD, 1/2" FNPT, PVC	1
	2044			2
	5550			
6	8018	002712	PLUG, 1/2" MNPT, PVC SCH-40	1
	2044			2
	5550			
7	ALL	015806	PLATE, REINFORCING, FRONT	1
8		015807	PLATE, REINFROCING, BACK	1
9		000459	SCREW, 1/4-20 x 5/8, FHPH, SS	2



## Section 8: Specifications and Parts

### Gate Assembly

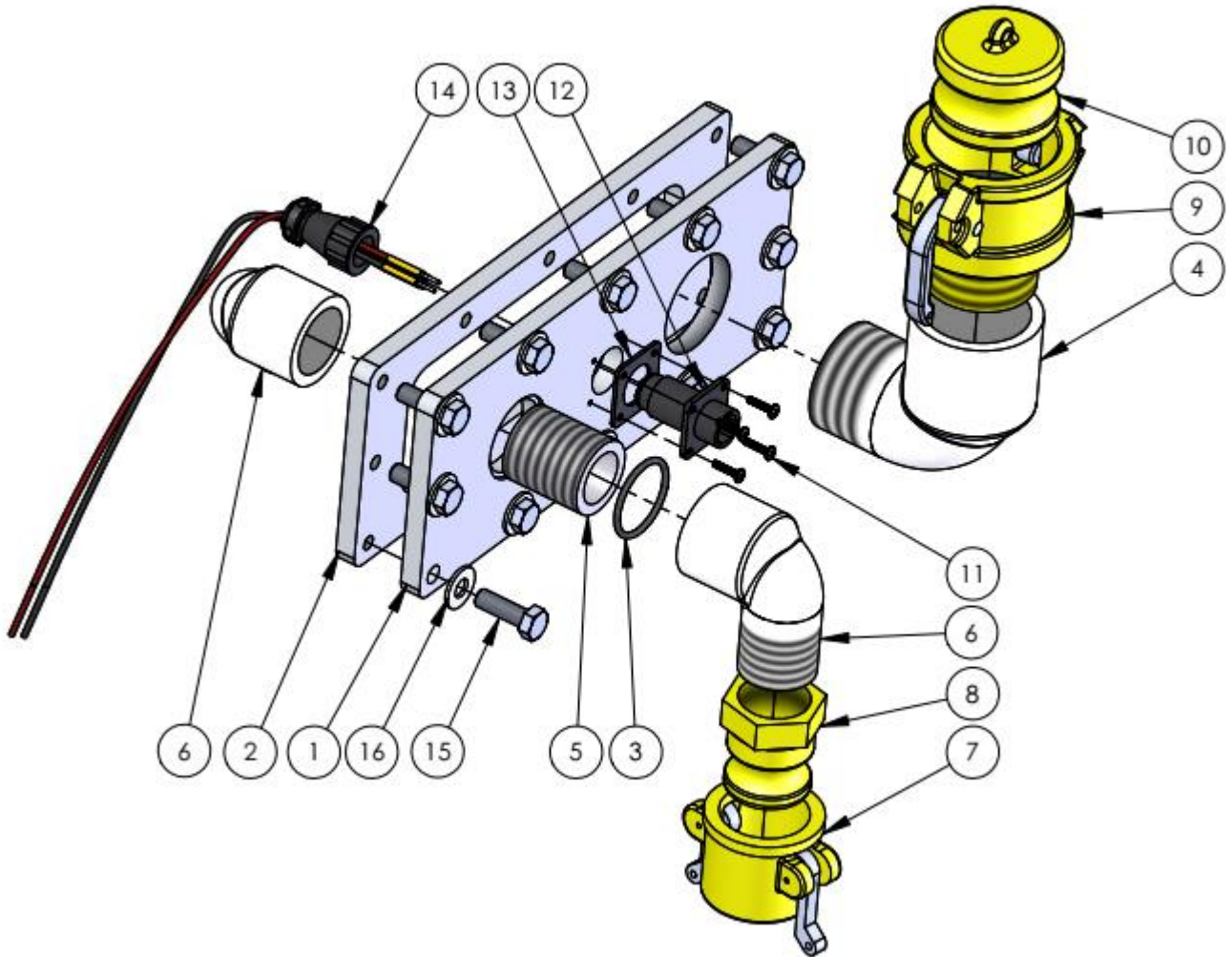

## Section 8: Specifications and Parts

### Gate Assembly (continued)

ITEM	MODEL	PART #	DESCRIPTION	QTY
1	ALL	014627	FLANGE, OUTER	1
2		004288	FLANGE, INNER	1
3		001890	O-RING, BUNA N, #124	1
4		002686	ELBOW, STREET, 1.5" NPT, PVC	1
5		002667	NIPPLE, CLS, 1" NPT, PVC	1
6		002685	ELBOW, STREET, 1" NPT, PVC	2
7		002655	CAMLOCK, DC, 1", NYL	1
8		002666	CAMLOCK, D, 1", NYL	1
9		002657	CAMLOCK, B, 1.5", NYL	1
10		002653	CAMLOCK, DP, 1.5", NYL	1
11		015759	SCREW, 4-40 X 1/2", PNPB, SS, SEAL	4
12		014492	RECEPTACLE, PM, 4 PIN, SEALING	1
13		014493	GASKET, SIZE-11	1
14		000955	CLAMP, 4 PIN, SMALL	1
15		000386	BOLT, HX, 5/16-18 X 1, SS	12
16		001807	WASHER, 5/16" X 3/4", 1/16", NYL	12

## Section 8: Specifications and Parts

### Pump Hose

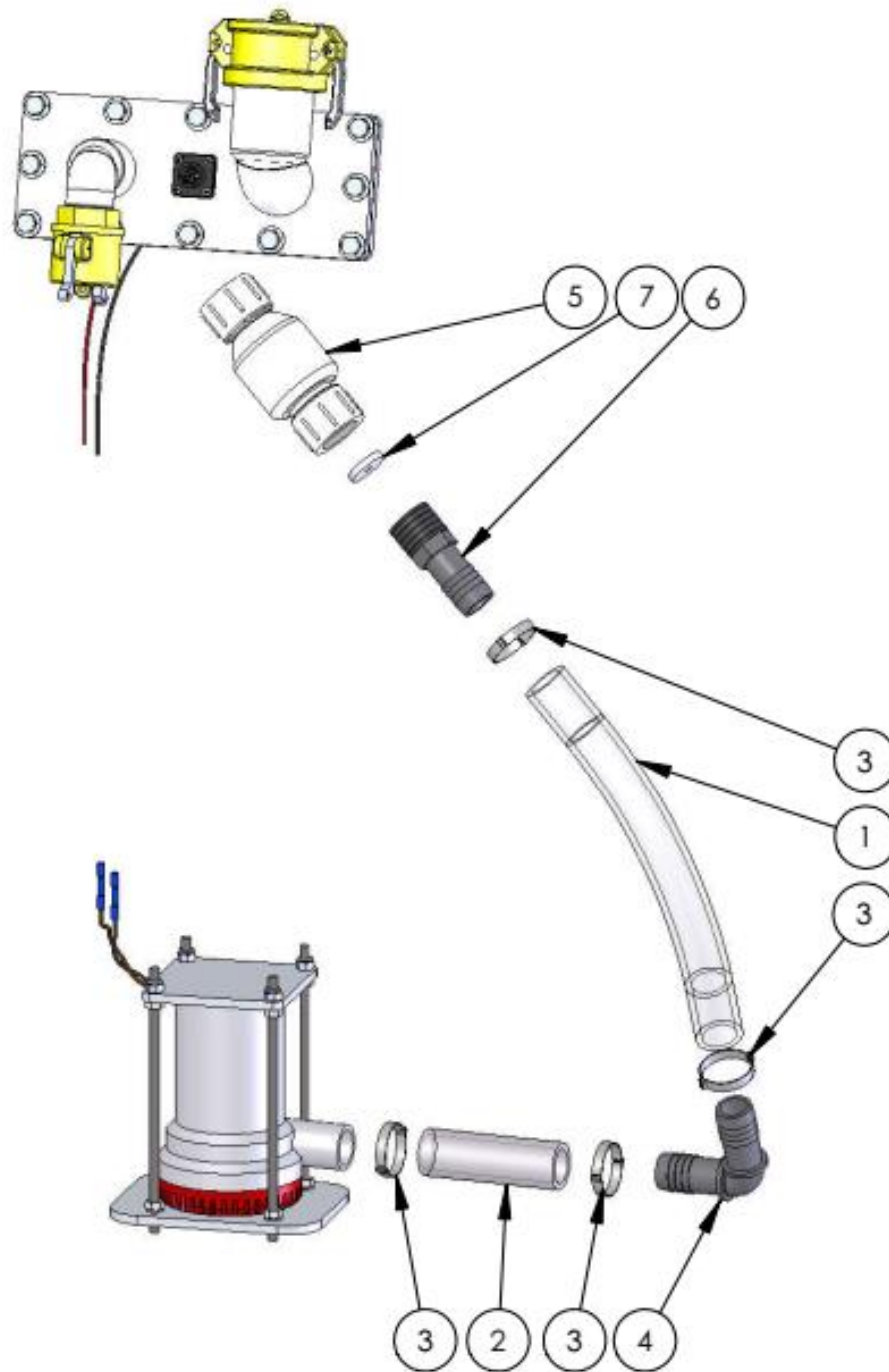

**Section 8: Specifications and Parts**

***Pump Hose (continued)***

ITEM	MODEL	PART #	DESCRIPTION	QTY		
1	8018	002892	TUBE, PVC, 1"	8 FT		
	2044			12 FT		
	5550			13 FT		
2	ALL			3 FT		
3				003049	CLAMP, OETIKER, 1-7/16", SS	4
4				002684	ELBOW, BARB, 1", PVC	1
5				002916	VALVE, CHECK, SPRING, 1", FNPT, PVC	1
6				002683	ADAPTER, BARB, 1" x 1", MNPT, PVC	1
7				005058	ORIFICE, 3/16	1

## Section 8: Specifications and Parts

### Pump Dispenser Assembly

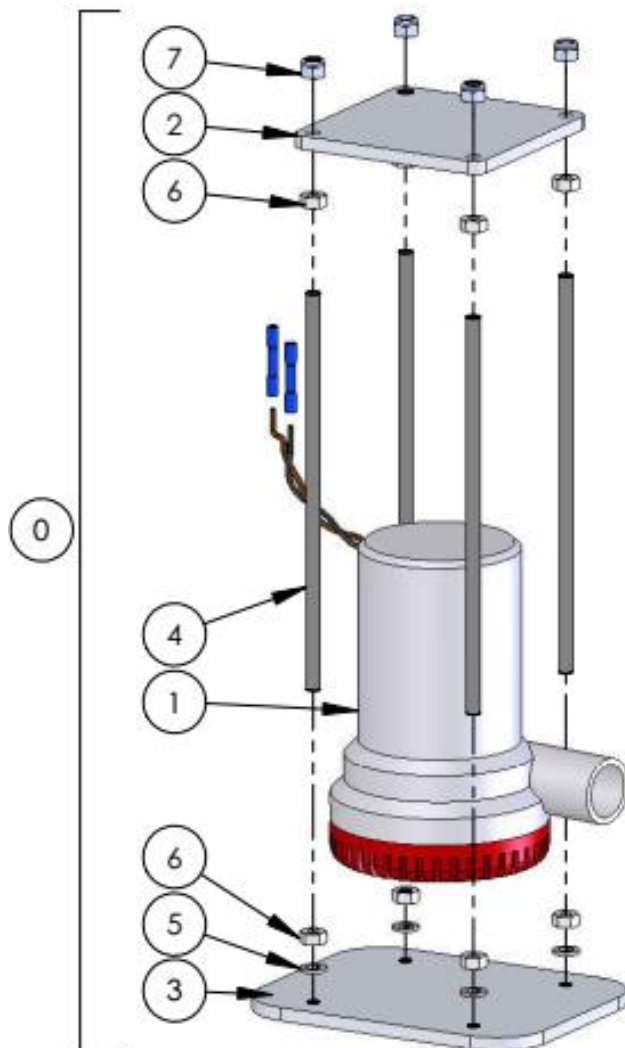

ITEM	MODEL	PART #	DESCRIPTION	QTY
0	ALL	004319	PUMP, DISPENSE, ASSY	1
1	ALL	004250	PUMP, 33GPM, 24V	1
2		004291	PLATE, TOP, PUMP	1
3		004292	PLATE, BOTTOM, PUMP	4
4		004293	ROD, MOUNTING	2
5		001852	WASHER, LOCK, SPLIT, 1/4, SS	4
6		001655	NUT, HX, 1/4-20, SS	4
7		001662	NUT, HX, NYL, 1/4-20, SS	4

## Section 8: Specifications and Parts

---

### Controller



ITEM	MODEL	PART #	DESCRIPTION	QTY
0	ALL	018871	CONTROLLER, BAMBI	1

## Section 8: Specifications and Parts

### External Parts

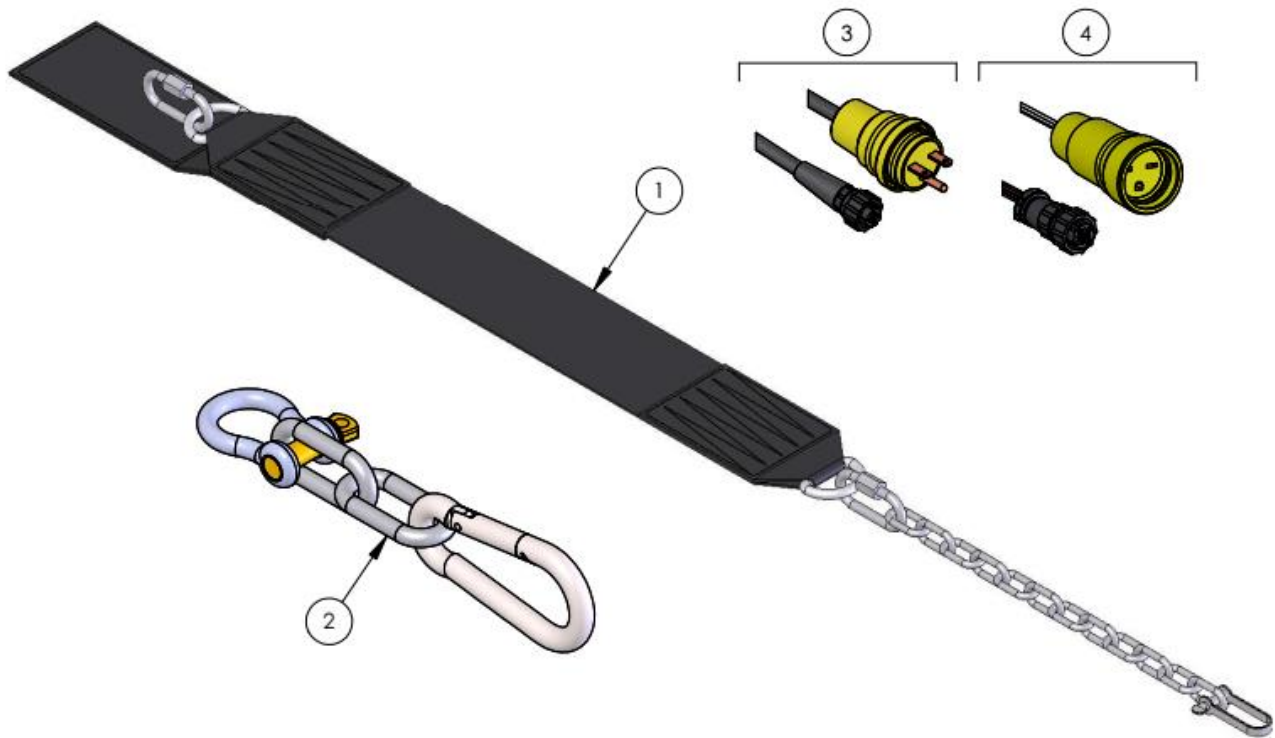

ITEM	MODEL	PART #	DESCRIPTION	QTY
1	8018	015953	RESTRAINER, STRAP, ASSY	1
	2044	015954		
	5550	015955		
2	8018	015958	HANGER, ASSY	5
	2044			7
	5550			
3	ALL	014635	HARNESS, LOWER, SACKSAFOAM	1
4		014636	HARNESS, UPPER, SACKSAFOAM	

# Section 9: Drawings

## Wiring Diagram

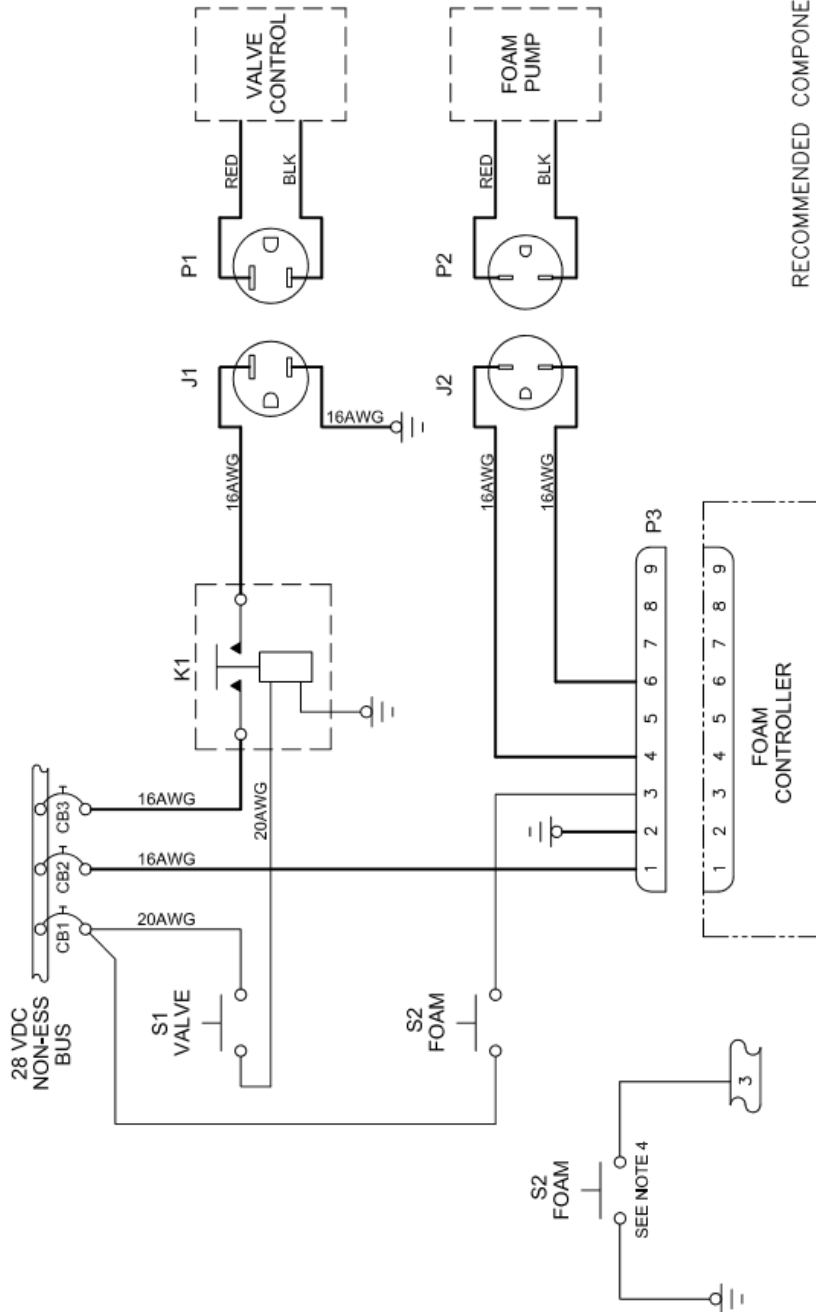

RECOMMENDED COMPONENTS

ITEM	DESCRIPTION	SPECIFICATION
CB1	CIRCUIT BREAKER, 1A	MS22073-1
CB2, CB3	CIRCUIT BREAKER, 10A	MS22073-10
K1	RELAY, SPST, 10A	MS24149F
S1, S2	SWITCH, SPST, MOMENTARY	MS24523-28
P3	CONNECTOR, PLUG, 9 SCKT	TE 206708-1
	CONTACT, SCKT, 18-16AWG	TE 66101-2
J1	CONNECTOR, RECEPTACLE, IP67	NEMA 5-15R, IP67
J2	CONNECTOR, RECEPTACLE, IP67	NEMA 6-15R, IP67
—	WIRE, #20 AWG	MS22759/16-20
—	WIRE, #16 AWG	MS22759/16-16

NOTES

1. THESE ARE RECOMMENDED INSTALLATION INSTRUCTIONS ONLY. ALL INSTALLATIONS TO BE DONE BY QUALIFIED PERSONNEL IN ACCORDANCE WITH APPLICABLE LOCAL REGULATIONS.
2. CONNECTION TO AIRCRAFT POWER SUPPLY DONE IN ACCORDANCE WITH FAA ADVISORY CIRCULAR AC43.13-1B AND AC43.12-2A. DO NOT CONNECT THE BAMBİ SYSTEM TO ANY AIRCRAFT BUS BAR THAT IS USED FOR EMERGENCY OR ESSENTIAL LOADS. AMEND THE AIRCRAFT ELECTRICAL LOAD ANALYSIS TO ENSURE THAT THE GENERATOR CAPACITY IS ADEQUATE TO OPERATE THE SYSTEM.
3. ALL GROUNDS, SOLDERED TERMINALS, AND CRIMPED TERMINALS DONE IN ACCORDANCE WITH AIRCRAFT MANUFACTURER'S INSTRUCTIONS.
4. SWITCH S2 MAY BE SET UP AS EITHER SOURCING OR SINKING AT THE OPERATOR'S PREFERENCE. THE CONTROLLER WILL AUTO DETECT.



**THIS PAGE INTENTIONALLY LEFT BLANK**

## Section 10: Warranty

---

### Section 10: Warranty

SEI Industries Ltd. (the company) agrees to grant a warranty for a period of one year from the date of purchase of Bambi Bucket systems on the following conditions:

- a) The company's sole obligation under this warranty is limited to repairing or replacing, at the company's sole discretion, any product shown to be defective.
- b) The company's products are not guaranteed for any specific length of time or measure of service, but are warranted only to be free from defects in workmanship and material for a period of one year to the original purchaser.
- c) To the extent allowable under applicable law, the company's liability for consequential and incidental damages is expressly disclaimed. **The company's liability in all events is limited to and shall not exceed, the purchase price paid.**
- d) This warranty is granted to the original purchaser of Bambi Bucket systems and does not extend to a subsequent purchaser or assignee.
- e) The company must receive notification in writing of any claims of warranty from the original purchaser which must give details of the claimed defect in the product.
- f) Where the original purchaser is claiming under warranty, the product must be returned to the company for inspection with all transportation and duty charges prepaid.
- g) The warranty does not extend to any product that has been accidentally damaged, abraded, altered, punctured, abused, misused or used for a purpose which has not been approved by the company.
- h) This warranty does not apply to any accessories used with the product that are not supplied by the company and any warranty on such accessories must be requested from the manufacturer or dealer of the accessories.
- i) In the event the original purchaser does not give notice of a warranty claim, within one year of the original purchase of the product, it is understood that the purchaser has waived the claim for warranty and the purchaser and/or any subsequent purchaser must accept the condition of the product, without warranty.
- j) Any technical information supplied by the company regarding the product is not a condition of warranty but rather is information provided by the company to the best of its knowledge.
- k) There are no implied warranties nor is there any warranty that can be assumed from any representation of any person, except the company itself.

#### **Exclusions**

- l) This warranty is void if the product is not installed, used and/or maintained in accordance with the operations manual supplied by SEI.