



Bambi
BUCKET®
Driven by Innovation



TORRENTULA VALVE REMOTE POWER SUPPLY OPERATOR'S MANUAL

Torrentula Valve Remote Power Supply

Operator's Manual

For use with Model 2732 to HL9800 Torrentula Valve Bambi Buckets

Kit part No. BTSK00750

Issue Date: August 2014

Revision: 0

SEI INDUSTRIES LTD.
7400 Wilson Avenue
Delta, BC, CANADA V4G 1E5
Tel: (604) 946-3131
Fax: (604) 940-9566
E-Mail: seisales@sei-ind.com
Web Site: www.sei-ind.com

COPYRIGHT@ 2004 SEI INDUSTRIES LTD. ALL RIGHTS RESERVED
PRINTED IN CANADA

Table of Contents

	Page
1. Instructions for use	3
2. Maintenance	4
3. Parts	5
4. Wiring diagram	8
5. Specifications	9
6. Warranty	10
Appendix	
A. Battery specifications	
B. Battery Material Safety Data Sheet	
C. Charger specifications	

1. Instructions for use

1.1 Charging prior to use

1. Set input voltage switch on charger to match supply voltage:
Select 110V /60 Hz or 220V / 50 Hz
2. Plug charger into AC supply

Caution: Always charge the RPS in the upright position.

3. Connect charger DC output connector to charge port receptacle on the Remote Power Supply (RPS)
4. Turn on charger
5. Monitor charger lights: Red light indicates charger is on, Amber light indicates charge condition
6. Charge is complete when amber light turns to green
7. Soneil 2408 model charger can remain connected indefinitely to maintain a full charge until the RPS is ready for use.

1.2 Connection to Torrentula Valve Controller box

1. Mount the Torrentula controller box to the top of the RPS, using the attached over-center latches. The RPS can be mounted to the side of the Torrentula controller if desired
2. Connect one end of wire harness H11 to the RPS output receptacle and the other end to receptacle #1 (R1) on the Torrentula Controller
3. Confirm that the Torrentula Controller power “on” LED is lit.
4. Locate grounding cable. Connect grounding cable to the charge port on the control box. Then connect alligator clip to ground connection in helicopter.

1.3 In-field charging

1. If the power supply is to remain connected to the Torrentula Controller, pull the RPS circuit breaker prior to connecting the charger
2. Full charge may take up to 4 hours
3. Reset RPS circuit breaker prior to use
4. In-flight charging of the RPS is not recommended.

Caution: Use only the supplied charger or charger suitable for charging 24 volt SLA type batteries. See appendix A for battery specifications. See Appendix C for battery charger specifications.

2. Maintenance

2.1 Troubleshooting

Problem	Cause	Solution
System will not operate when first connected	1. Missed cable connection 2. Batteries discharged	1. Double check all connections 2. Charge batteries
RPS voltage low	Batteries discharged	Charge batteries
RPS voltage low after four hours charging	Batteries old, damaged or defective	Replace batteries as a set
System stops operating suddenly	Excessive current draw circuit breaker tripped	Correct system fault, reset circuit breaker

2.2 Seasonal inspection, prior to use

1. Fully charge RPS
2. Check voltage. The minimum no-load voltage when fully charged should exceed 25 Volts at room temperature.
3. Inspect case and wire harnesses for damage and wear. Repair as necessary.

2.3 Maintenance during use

1. On condition

2.4 Storage

1. Clean external surfaces with a mild soapy rag.

Warning: do not immerse or pressure wash RPS case

2. Charge prior to storage
3. Store indoors away from moisture and direct sunlight at normal room temperature
4. Charge RPS every 3 months. Note: Soneil model 2408 charger may be connected indefinitely during storage to maintain full charge.

2.5 Battery life

Battery life is largely determined by conditions and frequency of use, but it is recommended that the batteries be replaced as a set at least every 5 years.

3. Parts

ITEM	SEI/P/N	DESCRIPTION	MATERIAL/SIZE	QTY.
1	BTSA00751	RPS BOX ONLY, WITH BATTERIES		1
2	BTSP00421	ENCLOSURE LID	ALUM	1
3	BTSP00427	"NO STEP" DECAL	VINYL, W/ ADHESIVE	1
4	BTSP00753	ENCLOSURE BASE	ALUM	1
5	BTSP00755	ENCLOSURE FACE PLATE	ALUM	1
6	BTSP00756	MACHINE TAG	ALUM	1
7	BTSP00757	ANGLE BRACKET #1	ALUM	2
8	BTSP00758	ANGLE BRACKET #2	ALUM	2
9	BTSP00759	ANGLE BRACKET #3	ALUM	1
10	BTSP00760	BATTERY CLAMP PLATE	ALUM	1
11	BTSA00761	BATTERY CHARGER	SONEIL 2408, W/PLUG	1
12	BPSA00311	WIRE HARNESS H11		1
13	BTSA00765	WIRE HARNESS W65		1
14	BTSA00766	WIRE HARNESS W66		1
15	BTSA00767	WIRE LEAD W67		1
16	BTSA00768	WIRE HARNESS W68		1
101	FBPF010450	BOLT	PLATED, 1/4-28 X 5" LG	6
102	FBSC040305	MACHINE SCREW, PANPHIL	SS, 10-24 X 5/8" LG	16
103	FBSC040203	MACHINE SCREW, PANPHIL	SS, 8-32 X 3/8" LG	14
104	FBSC030204	MACHINE SCREW, CSKPHIL	SS, 8-32 X 1/2" LG	16
105	FBSC040104	MACHINE SCREW, PANPHIL	SS, 6-32 X 1/2" LG	6
106	FBSF04005	MACHINE SCREW, PANPHIL	SS, 4-40 X 5/8" LG	8
107	FBSF04003	MACHINE SCREW, PANPHIL	SS, 4-40 X 3/8" LG	4
108	FNSF0204	NYLOCK NUT	SS, 1/4-28	9
109	FNSC0203	NYLOCK NUT	SS, 10-24	16
110	FNSC0202	NYLOCK NUT	SS, 8-32	30
111	FNSC0201	NYLOCK NUT	SS, 6-32	6
112	FNSF0200	NYLOCK NUT	SS, 4-40	12
113	FNSC0204	NYLOCK NUT	SS, 1/4-20	4
114	FWS0104H	THICK WASHER	SS, 1/4ID X 3/4OD X 1/8THK	6
115	FWS01040	PLAIN WASHER	SS, 1/4ID X 11/16OD	4
116	FWS060310	FENDER WASHER	SS, 1/4ID X 1"OD	6
117	FWR0106	NEOPRENE WASHER	RUBBER, 1/4ID X 1"OD	6
118	FWS0502	SPLITLOCK WASHER	SS, #8	14
119	FWS0304	PLAIN WASHER	SS, 1/4ID (AN960-416)	3
201	EBAT003	BATTERY	SLA, 12V 7.2Ah	4
202	EBRE030	CIRCUIT BREAKER	30 AMP, MS14105-30	1
203	PP023	RUBBER-LINED CLAMP	STEEL, #4, 1/4" ID	3
204	PP265	EYE STRAP	SS, 2" THROAT	4
205	PP722	VIBRATION MOUNT	RUBBER, 1/4" STUD	4
206	PP260	CATCH	SS	4
207	EWIRA004	HEAT SHRINK TUBING	POLYOLEFIN	2 FT.
208	ECON97MS062	RECEPTACLE CAP	#20 SHELL	1
209	ECON97MS061	RECEPTACLE CAP	#14 SHELL	1
210	ETERM002	TERMINAL STRIP	4 CONTACT	1

3. Parts

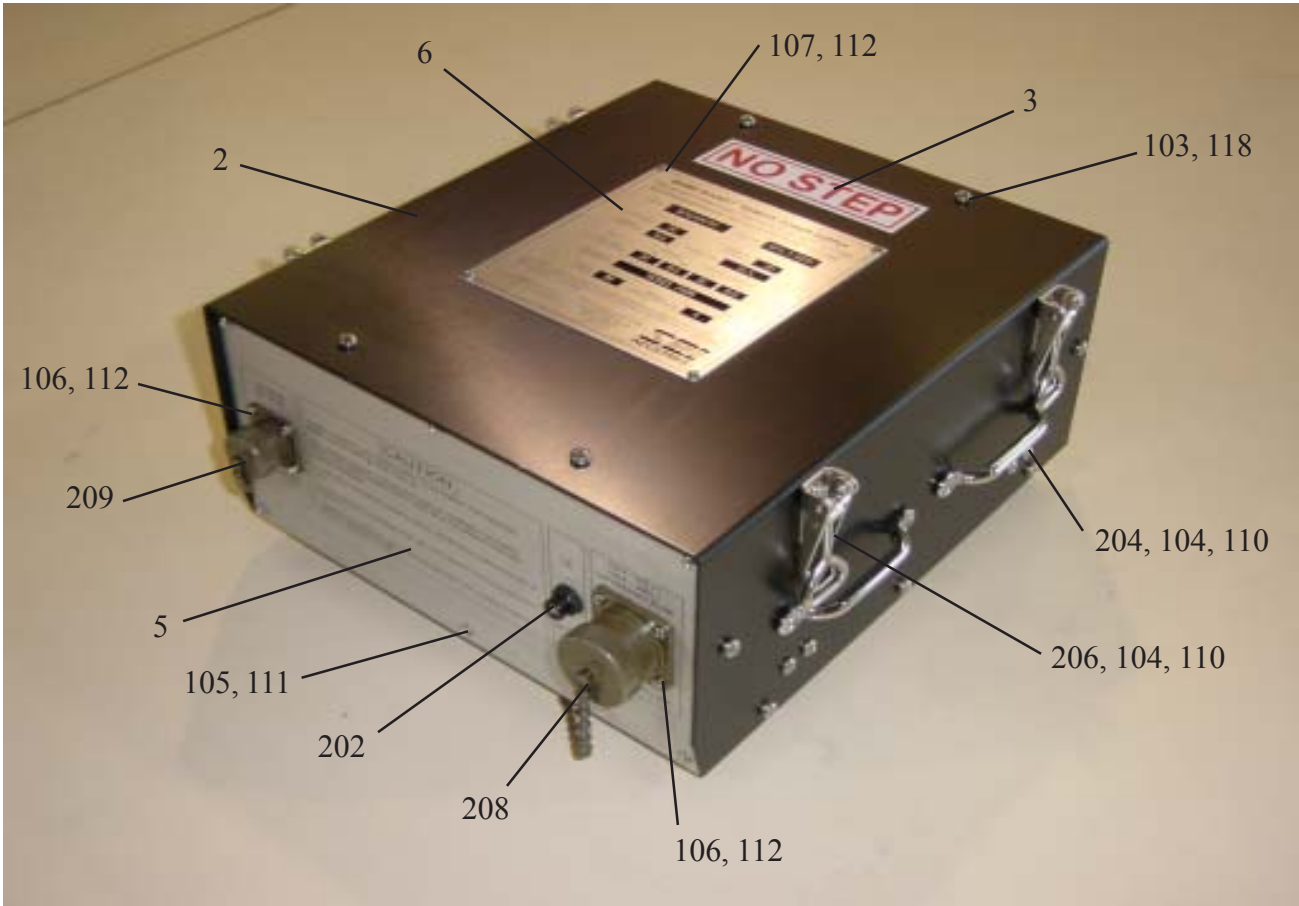
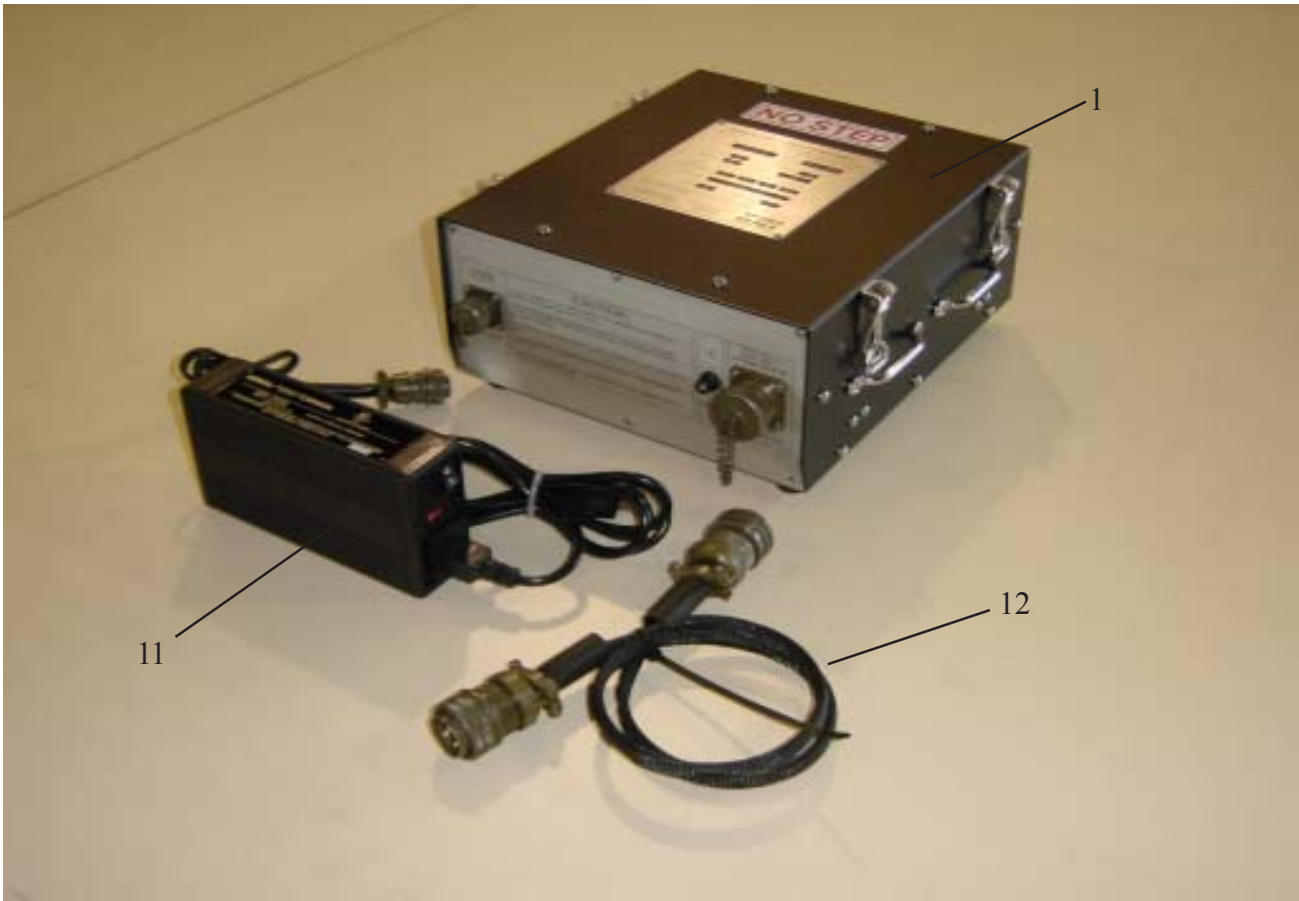

3. Parts

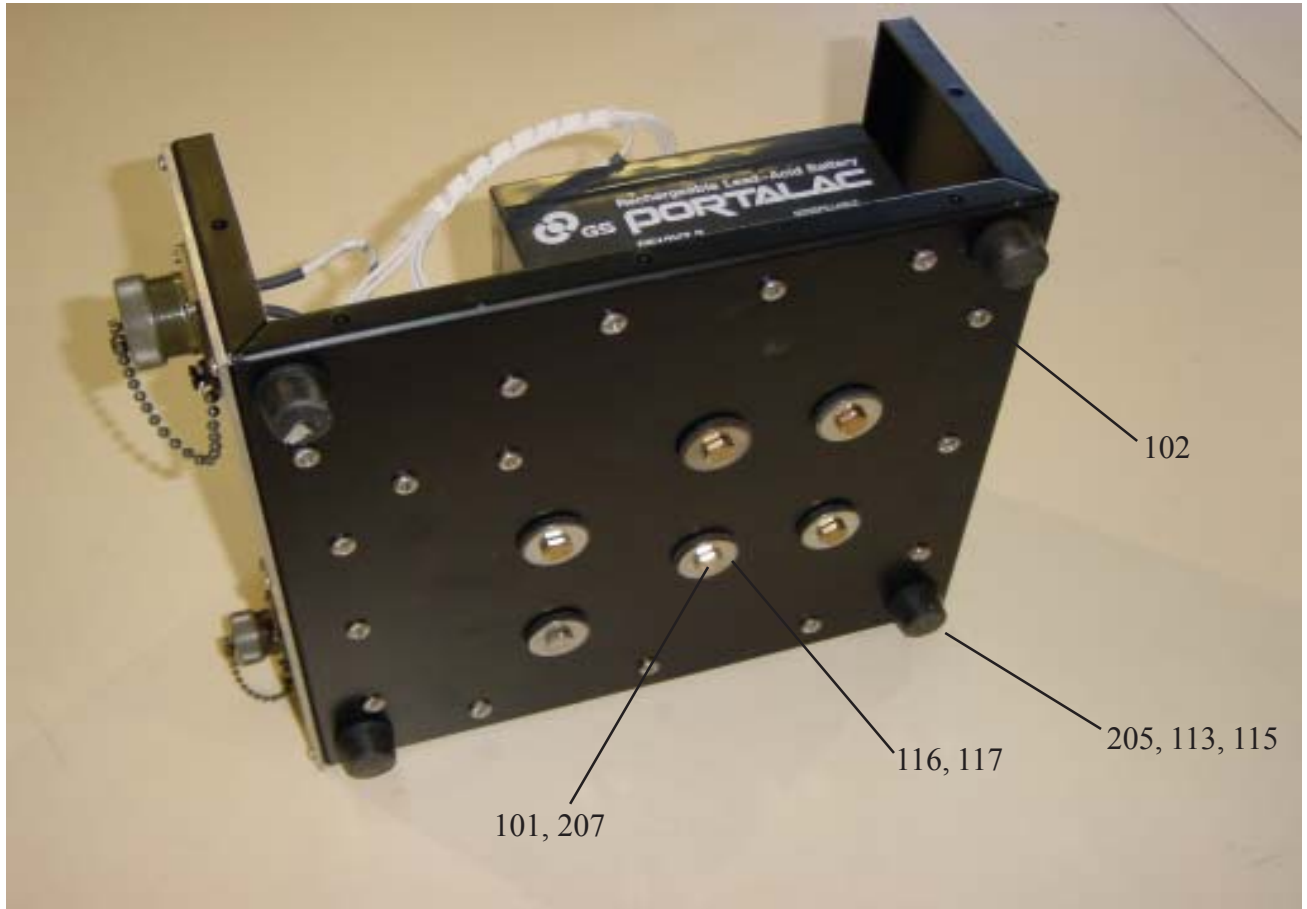
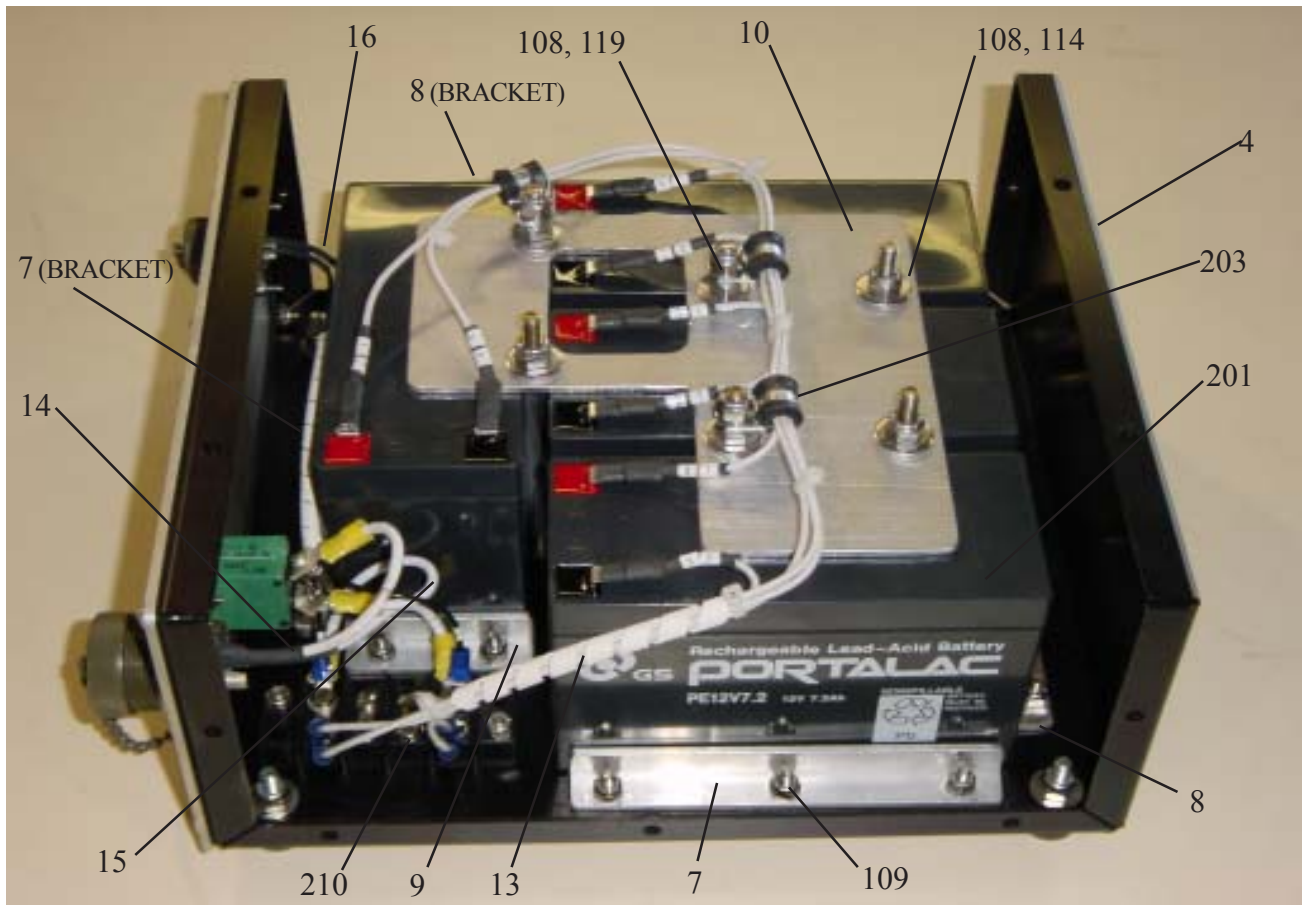

4. Wiring Diagram

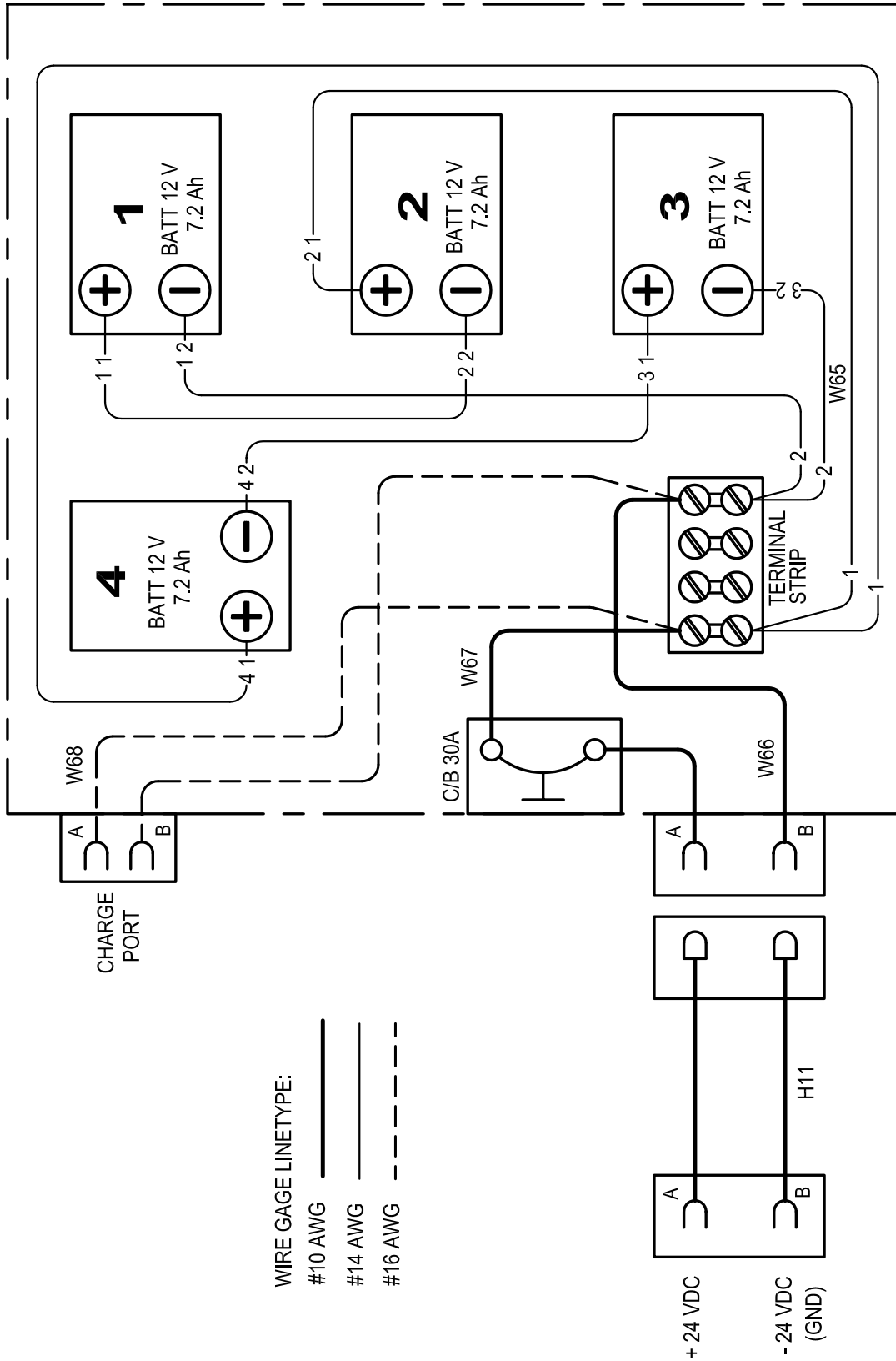

5. Specifications

TORRENTULA VALVE REMOTE POWER SUPPLY

Kit P/N: BTK00750

Recommended use

Independent rechargeable power supply for operation and maintenance of Torrentula Valve Bambi buckets

Battery pack specifications

Type: Sealed Lead-Acid (SLA)

Voltage: 24V DC

Capacity: 14.4 Ah

Configuration: 2S-2P, 4 x 12v 7.2 Ah batteries

Performance: 200 - 300 open and close cycles per charge

Recharge time: Maximum 4 hours w/supplied charger

Dimensions

RPS case: 13" L x 12-1/8" W x 5-1/2" H (33 x 31 x 14 cm)

Power lead length: 24" (0.61m)

Charger: 6.9" L x 3.7" W x 1.9" H (18 x 9.4 x 4.8 cm)

Weights

RPS, with power lead: 35 lb (15.9 kg)

RPS only: 34 lb (15.4 kg)

Charger: 1.5 lbs (0.68 kg)

Construction

Enclosure: 0.80" (2mm) 5052-T3 aluminum, black anodized finish

Wiring: MIL-W-22759/16

Circuit breaker: MIL-C-5809

Connectors: Mil-C-5105

Cargo tie-down: 4 x 200lb (91 kg) eye straps

Charger power requirements

110 / 60Hz AC or 220 / 50Hz AC, single phase

Standard equipment included with RPS

- 24 volt battery charger
- Power output lead

Optional equipment

- RPS case with batteries only, PN BTSA00751
- Charger only, PN BTSA00761

6. Warranty

SEI Industries Ltd. (The Company) agrees to grant a Warranty for a period of one year from the date of purchase of Bambi Bucket systems on the following conditions:

- a) The Company's sole obligation under this Warranty is limited to repairing or replacing, at the company's sole discretion, any product proved to be defective.
- b) The Company's products are not guaranteed for any specific length of time or measure of service, but are warranted only to be free from defects in workmanship and material for a period of one year to the original purchaser.
- c) To the extent allowable under applicable law, the Company's liability for consequential and incidental damages is expressly disclaimed. **The Company's liability in all events is limited to, and shall not exceed, the purchase price paid.**
- d) This Warranty is granted to the original purchaser of Bambi Bucket systems and does not extend to a subsequent purchaser or assignee.
- e) The Company must receive notification in writing of any claims of Warranty from the original purchaser which must give details of the claimed defect in the product.
- f) Where the original purchaser is claiming under Warranty, the product must be returned to the Company for inspection with all transportation and duty charges prepaid.
- g) The Warranty does not extend to any product that has been accidentally damaged, abraded, altered, punctured, abused, misused or used for a purpose which has not been approved by the Company.
- h) This Warranty does not apply to any accessories used with the product that are not supplied by the Company, and any Warranty on such accessories must be requested from the manufacturer or dealer of the accessories.
- i) In the event the original purchaser does not give notice of a Warranty claim within one year of the original purchase of the product, it is understood that the purchaser has waived the claim for Warranty and the purchaser and/or any subsequent purchaser must accept the condition of the product as it may be, without Warranty.
- j) Any technical information supplied by the Company regarding the product is not a condition of Warranty but rather is information provided by the Company to the best of its knowledge.
- k) There are no implied warranties nor is there any Warranty that can be assumed from any representation of any person, except the Company itself.

Exclusions

- l) This Warranty is void if the product is not installed, used and/or maintained in accordance with the Field Manual supplied by SEI.
- m) All Bambi Buckets are designed and manufactured with substantial safety margins. It is the responsibility of the user to ensure that the bucket is maintained to a safe standard.

Appendix A
Battery specifications

GS Portalac PE12V7.2

General Specifications
7/17/2000

- 1** Nominal Voltage
- 2** Nominal Capacity
- | | | | |
|--------|-----------|---------|---------|
| 0.05 C | 0.36 A to | 10.50 V | 7.20 Ah |
| 0.10 C | 0.72 A to | 10.50 V | 6.60 Ah |
| 0.20 C | 1.44 A to | 10.20 V | 5.76 Ah |
| 1.00 C | 7.20 A to | 9.00 V | 3.74 Ah |
- 3** Dimensions
- | | Length | Width | Height | Terminal Height |
|--------|--------|-------|--------|-----------------|
| Inches | 5.94 | 2.56 | 3.70 | 3.86 |
| mm | 151.0 | 65.0 | 94.0 | 98.0 |
- 4** Weight (Approx.)
- 5** Internal Resistance (approximatley) mOhm
- 6** Energy Density @ 0.05C
- | | |
|---------------------------|-------|
| Watt-Hours Per Cubic Inch | 1.53 |
| Watt-Hours Per Litre | 93.65 |
- 7** Specific Energy @ 0.05C
- | | |
|----------------------|-------|
| Watt-Hours Per Pound | 14.25 |
| Watt-Hours Per Kg | 31.42 |
- 8** Maximum Discharge Current with standard terminals Amperes
- 9** Maximum Short Duration Discharge Current (less than 5 sec.) Amperes
- 10** Vibration Test (2000 cycles/minute, 0.10 inch excursion, 2 hours)
No loss in capacity or performance
- 11** Charge Retention (shelf life)
- | % of nominal capacity at 77°F (25°C) | |
|--------------------------------------|-----|
| 1 month | 97% |
| 3 months | 91% |
| 6 months | 85% |
- 12** Operating Temperature Range
- | | | | |
|-----------|--------------|----|--------------|
| Charge | 32°F (0°C) | to | 104°F (40°C) |
| Discharge | -4°F (-20°C) | to | 122°F (50°C) |
| Storage | -4°F (-20°C) | to | 104°F (40°C) |
- 13** Case Material
Synthetic resin (ABS)
- 14** Standard Terminal
F1: Amp Faston Type 187

Constant Voltage Recharge Methods

Cyclic Use:	Charging Voltage	<input type="text" value="14.40"/>	~	<input type="text" value="14.70"/>	Volts DC
	Maximum Initial Charging Current	<input type="text" value="1.80"/>	Amperes		
	*Recommended Minimum Initial Charging Current	<input type="text" value="0.72"/>	Amperes		
	Remove from Charge or Switch to Standby Charge when Current Draw Falls to	<input type="text" value="72"/>	mA		

Standby Use:	Charging Voltage	<input type="text" value="13.50"/>	~	<input type="text" value="13.80"/>	Volts DC
	*Recommended Standby Charging Voltage	<input type="text" value="13.65"/>	Volts DC		
	Maximum Initial Charging Current	<input type="text" value="No Limit"/>			

Appendix B
Battery MSDS



**GS Battery USA Inc., a subsidiary of
JAPAN STORAGE BATTERY CO. LTD.**

Material Safety Data Sheet

GS PORTALAC, PE, PX, PXL, and PWL Series VALVE
REGULATED LEAD ACID (VRLA) BATTERY, ABSORBED
ELECTROLYGE (AGM)

Section I – Product Identification

Manufacturer's name GS Battery USA Inc. 1000 Mansell Exchange West Suite 350 Alpharetta GA 30022	Emergency Telephone Number
	CHEMTREC: (800) 424-9300
	Telephone Number for Information
	GS Battery USA Inc.: (678) 762-4818
Date Issued:	April 1 2002.
Date Updated:	May 26. 2004.

Section II—Hazardous Ingredients/Identity Information

Components)	CAS Number	Approx wt%	OSHA PEL ($\mu\text{g}/\text{m}^3$)	ACGIH TLV ($\mu\text{g}/\text{m}^3$)	NIOSH ($\mu\text{g}/\text{m}^3$)
Inorganic Lead/Lead Compounds	7439-92-1	65%-75%	50	150	10
Tin	7440-31-5	<.5%	2000	2000	N/A
Calcium	7440-70-2	<0.1%	N/A	N/A	N/A
Electrolyte: Dilute Sulfuric Acid	7664-93-9	14-20%	1000	1000	1000
Case Material: Acrylonitrile Butadiene Styrene	9003-56-9	5-10%	N/A	N/A	N/A

Inorganic lead and electrolyte (sulfuric acid) are the main components of every VALVE REGULATED LEAD ACID battery manufactured by Japan Storage Battery Co. LTD. Other ingredients may be present dependent upon the specific battery type. Contact Japan Storage Battery Co. LTD (JAPAN) or GS Battery USA Inc.(North America) for additional information.

Section III—Physical/Chemical Characteristics

ELECTROLYTE (Sulfuric Acid, dilute)

Boiling Point	203°F-240°F	Specific Gravity (H ₂ O = 1)	1.230 to 1.350
Vapor Pressure (mm Hg)	10-17	Melting Point	N/A
Vapor Density (AIR = 1)	Greater than 1	Evaporation Rate (Butyl Acetate = 1)	Less than 1
Solubility in Water	100%	Appearance and Odor	Electrolyte: Clear liquid with sharp, penetrating, pungent odor.

Section IV—Fire and Explosion Hazard Data

Flash Point (Method Used) N/A		LEL 4.1% (H ₂ Gas_)	UEL
Flammable Limits:	LEL = 4.1% (Hydrogen Gas), UEL = 74.2%		
Extinguishing Media:	CO ₂ , foam, dry chemical		
Special Fire Fighting Procedures	If batteries are on charge, shut of power. Use positive pressure, self-contained breathing apparatus. Beware of acid splatter during water application and wear acid resistant clothing, gloves, face and eye protection.		
Unusual Fire and Explosion Hazards	VRLA batteries generate highly flammable hydrogen gas during operation. To avoid risk of fire or explosion, keep sparks and other sources of ignition away from batteries. Do not allow metallic articles to simultaneously contact the negative and positive terminal of the battery.		

Section V—Reactivity Data

Stability	Unstable		Conditions to Avoid
	Stable	X	Prolonged overcharge on high current, ignition sources

Incompatibility (Materials to Avoid)

Sulfuric acid: Contact with combustibles and organic materials may cause fire and explosion. Also reacts violently with strong reducing agents, metals, sulfur trioxide gas, strong oxidizers, and water. Contact with metals may product toxic sulfur dioxide fumes and may release flammable hydrogen gas

Lead Compounds: Avoid contact with strong acids, bases, halides, halogenates, potassium nitrate, permanganate, peroxides, nascent hydrogen, and reducing agents.

Hazardous Decomposition or Byproducts

Sulfuric acid: Sulfur trioxide, carbon monoxide, sulfuric acid mist, sulfur dioxide, and hydrogen sulfide.

Lead Compounds: High temperatures above the melting point are likely to produce toxic metal fume, vapor, or dust; contact with strong acid or base or presence of nascent hydrogen may generate highly toxic arsine gas..

Hazardous Polymerization

Section VI—Health Hazard Data

Route(s) of Entry

Sulfuric acid: Harmful by all routes of entry.

Lead Compounds: Hazardous exposure can occur only when product is heated, oxidized, or otherwise process or damaged to create dust, vapor or fume.

Inhalation?

Sulfuric acid: Breathing sulfuric acid vapors and mists may cause severe respiratory.

Lead Compounds: Dust or fumes may cause irritation of upper respiratory tract or lungs

Skin Contact

Sulfuric acid: Severe irritation, burns and ulceration.

Lead Compounds: Not absorbed through the skin.

Ingestion

Sulfuric acid: May cause severe irritation of the mouth, throat, esophagus, and stomach.

Lead Compounds: May cause abdominal pain, nausea, vomiting, diarrhea, and severe cramping. Acute ingestion should be treated by a physician.

Eye Contact

Sulfuric acid: Severe irritation, burns, cornea damage, and possible blindness.

Lead Compounds: May cause eye irritation.

Acute Health Hazards

Sulfuric acid: Severe skin irritation, burns, damage to cornea may cause blindness, upper respiratory irritation.

Lead Compounds: May cause abdominal pain, nausea, headaches, vomiting, loss of appetite, severe cramping, muscular aches and weakness, and difficulty sleeping.

Chronic Health Hazards

Sulfuric acid: Possible scarring of the cornea, inflammation of the nose, throat and bronchial tubes, possible erosion of tooth enamel.

Lead Compounds: May cause anemia, damage to kidneys and nervous system, and damage to reproductive system in both males and females.

Carcinogenicity

Sulfuric acid: The National Toxicological Program (NTP) and The International Agency for Research on Cancer (IARC) have classified .strong inorganic acid mist containing sulfuric acid. as a Category 1 carcinogen, a substance that is carcinogenic to humans. The ACGIH has classified .strong inorganic acid mist containing sulfuric acid. as an A2 carcinogen (suspected human carcinogen). These classifications do not apply to liquid forms of sulfuric acid or sulfuric acid solutions contained within a battery. Inorganic acid mist (sulfuric acid mist) is not generated under normal use of this product. Misuse of the product, such as overcharging, may result in the generation of sulfuric acid mist.

Lead Compounds: - Human studies are inconclusive regarding lead exposure and an increased cancer risk. The EPA and the International Agency for Research on Cancer (IARC) have categorized lead and inorganic lead compounds as a B2 classification (probable/possible human carcinogen) based on sufficient animal evidence and inadequate human evidence.

Medical Conditions Generally Aggravated by Exposure

Inorganic lead and its compounds can aggravate chronic forms of kidney, liver, and neurologic diseases. Contact of battery electrolyte (acid) with the skin may aggravate skin diseases such as eczema and contact dermatitis. Overexposure to sulfuric acid mist may cause lung damage and aggravate pulmonary conditions.

Emergency and First Aid Procedures

Inhalation:

Sulfuric acid: Remove to fresh air immediately. If breathing is difficult, give oxygen
Lead Compounds: Remove from exposure, gargle, wash nose and lips, consult physician

Ingestion:

Sulfuric acid: Do not induce vomiting, consult a physician immediately.
Lead Compounds: Consult a physician immediately

Eyes

Sulfuric acid: Flush immediately with water for 15 minutes, consult a physician.
Lead Compounds: Flush immediately with water for 15 minutes, consult a physician

Skin:

Sulfuric acid: Flush with large amounts of water for at least 15 minutes, remove any contaminated clothing. If irritation develops seek medical attention.
Lead Compounds: Wash with soap and water.

Section VII—Precautions for Safe Handling and Use

Steps to Be Taken in Case Material Is Released or Spilled

There is no release of material unless the case is damaged or battery is misused/overcharged. If release occurs stop flow of material, contain/absorb all spills with dry sand, earth, or vermiculite. Do not use combustible materials. Neutralize spilled material with soda ash, sodium bicarbonate, lime, etc. Wear acid-resistant clothing, boots, gloves, and face shield. Dispose of as hazardous waste. Do not discharge un-neutralized acid to sewer

Waste Disposal Method

Spent Batteries – send to secondary lead smelter for recycling. Follow applicable federal, state and local regulations Neutralize as in preceding step. Collect neutralized material in sealed container and handle as hazardous waste as applicable.

Precautions to Be Taken in Handling and Storing

Store batteries in a cool, dry, well ventilated area that are separated from incompatible materials and any activities which may generate flames, sparks, or heat. Keep all metallic articles that could contact the negative and positive terminals on a battery and create a short circuit condition.

Section VIII—Control Measures

Respiratory Protection (Specify Type)

None required under normal conditions. If battery is overcharged and concentrations of sulfuric acid are known to exceed PEL use NIOSH or MSHA approved respiratory protection.

Engineering Controls:

Store and handle batteries in a well ventilated area. If mechanical ventilation is used, components must be acid resistant

Protective Gloves

None needed under normal conditions. If battery case is damaged use rubber or plastic gloves with elbow length gauntlet.

Eye Protection

None needed under normal conditions. IF handling damaged or broken batteries use chemical splash goggles or face shield.

Other Protective Clothing or Equipment

None needed under normal conditions. In case of damaged or broken battery use an acid resistant apron. Under severe exposure or emergency conditions wear acid resistant clothing.

Work/Hygienic Practices

Handle batteries carefully to avoid damaging the case. Do not allow metallic articles to contact the battery terminals during handling. Avoid contact with the internal components of the battery.

Section IX—Regulatory Information

NFPA Hazard Rating for sulfuric acid

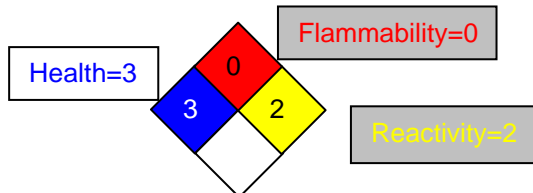

Transportation:

U.S. DOT/IMDG/IATA Shipping information

Proper Shipping Name: Batteries, wet, non-spillable
 Hazard Class: 8
 ID Number: UN2800
 Packing Group: 3
 Label/Placard: CORROSIVE

GS Battery USA Inc.'s Portalac series VRLA batteries have been tested and meet the "non-spillable electric storage batteries" criteria as required by DOT CFR 49, 173.159 (d), and IMO/IMDG, and ICAO/IATA packaging instructions 806 and A67, and therefore are non-regulated as long as the following criteria are met:

1. The batteries must be protected against short circuits and securely packaged.
2. The batteries and their outer packaging must be plainly and durably marked "NON-SPILLABLE" or "NONSPILLABLEBATTERY".

Contact your GS Battery USA Inc. representative for additional informational regarding the classification of batteries.

Regulatory Information

RCRA: Spent lead-acid batteries are not regulated as hazardous waste by the EPA when recycled, however state and International regulations may vary.

CERCLA (Superfund) and EPCRA:

- (a) Reportable Quantity (RQ) for spilled 100% sulfuric acid under CERCLA (Superfund) and EPCRA (Emergency Planning Community Right to Know Act) is 1,000 lbs. State and local reportable quantities for spilled sulfuric acid may vary.
- (b) Sulfuric acid is a listed "Extremely Hazardous Substance" under EPCRA, with a Threshold Planning Quantity (TPQ) of 1,000 lbs.
- (c) EPCRA Section 302 notification is required if 1,000 lbs. or more of sulfuric acid is present at one site. The quantity of sulfuric acid will vary by battery type. Contact GS Battery USA Inc. for additional information.
- (d) EPCRA Section 312 Tier 2 reporting is required for batteries if sulfuric acid is present in quantities of 500 lbs. or more and/or if lead is present in quantities of 10,000 lbs. or more.
- (e) Supplier Notification: This product contains toxic chemicals, which may be reportable under EPCRA Section 313 Toxic Chemical Release Inventory (Form R) requirements. If you are a manufacturing facility under SIC codes 20 through 39, the following information is provided to enable you to complete the required reports:

Toxic Chemical	CAS Number	Approximate % by Wt.
Lead	7439-92-1	60
Sulfuric Acid	7664-93-9	30
Arsenic	7440-38-2	0.2

If you distribute this product to other manufacturers in SIC Codes 20 through 39, this information must be provided with the first shipment of each calendar year. The Section 313 supplier notification requirement does not apply to batteries, which are "consumer products". Not present in all battery types. Contact GS Battery USA Inc. for additional information.

TSCA

Ingredients in GS Battery USA Inc.'s batteries are listed in the TSCA Registry as follows:

Components	CAS Number	TSCA Status
Electrolyte		
Sulfuric Acid (H ₂ SO ₄)	7664-93-9	Listed
Inorganic lead Compound:		
Lead (Pb)	7439-92-1	Listed
Lead Oxide (PbO)	1317-36-8	Listed
Lead Sulfate (PbSO ₄)	7446-14-2	Listed
Arsenic (As)	7440-38-2	Listed
Calcium (Ca)	7440-70-2	Listed
Tin (Sn)	7440-31-5	Listed

Appendix C
Charger specifications



SPECIFICATIONS - 2408CAA Supercharger

Totally Automatic Switch-Mode Battery Chargers

"Suitable for Gel, Sealed & Wet Lead Acid Batteries"

Summary: **24 V, 4A Constant Current**
(equivalent to 8A tapered charger in charging time)

- Automatic Cut-off and then true Float. Can be left connected indefinitely without harming the battery.
- **UL and cUL (Canada) Listed.**
- **Input 115/230 VAC** - Suitable for U.S., Canada, Japan, Europe.
- Suitable for Off-board (external) & On-board (internal) Applications
- Increases battery life by de-sulfating the battery.
- Many advance features described in this spec.
- **Very small size and very light weight**

Explanation of the Features:

The advance technology of the OEM Battery Chargers supplied by Soneil is fundamentally different from other battery chargers. The conventional linear battery charger is an electrical device whereas the 2408CAA is a light weight sophisticated electronic device.

1. Switch-Mode Technology:

Most of the battery chargers use linear technology which convert the 115/230 VAC to 24 VDC at 60/50 Hz. This requires a large transformer which has the disadvantage of lower efficiency resulting in higher heat generation, larger size and weight.

Soneil's Battery Charger transforms the 115/230 VAC into 24 VDC at 100,000 Hz (3333 times faster than conventional charger) which requires a much smaller transformer and this results in a unit of smaller size, low weight and improved efficiency.

The 2408CAA Supercharger uses sophisticated electronic circuitry with microchips. All present day computers use switch-mode technology.

2. **International Safety Approvals & Listings:**

Both UL and cUL (Canada) listings in a single charger.

3. **Input Requirements:** Dual Voltage - Switch selectable

a) 115 VAC (range 90 - 140 VAC) or
230 VAC (range 180 - 280 VAC)

b) 47 - 63 Hz

Input AC tolerance +/- 20%. This means 2408CAA Supercharger will operate satisfactorily in areas where the input voltage is low.

This charger is also **suitable for every part of the world** including **Japan** where input is 100 VAC.

4. **Output:**

4.0 Amps Constant Current @ 24 Volts DC
(Equivalent to 8 Amps tapered in charging time)

a) Line Regulation @ Full Load 2%

b) Load Regulation @ 115/230 VAC 3%

c) **Ripple Voltage:** Very low

The peak to peak ripple voltage into a resistive load is less than 200mV for the output voltage above 24 VDC.

5. **Charging Cycle:**

The charging curve is attached. The explanation of the charging cycle is as following.

a) **AC connected and battery not connected:**

When the charger is connected to the AC power, the red light will be ON, showing that AC power is connected. If the output is not connected to the battery, the green light will flash informing the user that battery side is not connected. Some of the scooter users may be old and if they forget to connect the battery side, the green flashing light reminds them.

b) **Charging:**

When the charger is connected to the battery and AC is plugged in, the red (power) and yellow (charging) light will be ON.

i) **Deep discharge battery:**

The charger can start charging at the battery voltage as low as 0.5 volts. Soneil charger can charge a very deeply discharged battery. Not many chargers can do this. When charging starts, up to 5 volts, the current is 1/3rd of full current. We want to protect a very deeply discharged battery and do not want to give full current. This charging from 0.5V to 5V only takes few seconds (sometime a fraction of a second) and sometimes it is difficult to measure without sensitive equipment. The red and yellow lights will be on.

Then charger will charge at about full constant current rate and the red & yellow light will be on. Due to the constant current, the charging time will be same as a tapered charger of twice the current rating (e.g. In charging time the Soneil 4A constant current charger is equivalent to 8A tapered charger).

ii) **Full Charge:**

When the battery voltage reaches about 28.8 volts (called upper cut-off voltage), the yellow light changes to green light.

iii) **Maintaining full charge:**

Soneil charger maintains the battery at full charge and does not overcharge. This is done by pulse charging. The light remains green.

At upper cut-off voltage, the charger shuts-off complete (zero current). When the battery voltage falls (due to internal losses) to 27.6 volts (lower cut-off which is standby voltage), the charger turns ON and gives a current until the voltage reaches upper cut-off of 28.8V (gives a pulse of current). Then the charger shuts-off again.

By using the pulse method for final charging, the Soneil charger maintains the battery at full charge at all time without overcharging. For a new battery with lower internal losses, the pulses are less often. With an older battery with higher internal losses, the pulses are more often. The charger adjusts itself to the requirement of the battery.

Soneil charger can charge gel or sealed lead acid batteries without use of any switch.

6. **Temperature compensation:**

This is an advanced feature normally not found in most chargers. This charger automatically adjusts its output at temperatures above 75°F when the batteries need less terminal voltage to fully charge.

The maximum output voltage and the float voltage will be reduced for ambient temperature above 75°F by $(.03 \pm 0.003)V/^{\circ}F$.

7. **Two colors in one LED:**

LEDs are used to show the charging status. The Red LED shows AC on. The second bicolour LED shows Yellow when charging and changes to Green when the battery is fully charged. The charger will continue to provide very small current to cover internal losses and will maintain the battery at full charge.

8. **Very low voltage start:** 0.5 Volts

Will charge very deeply discharged batteries. Many 24 volts chargers in the market will not charge batteries discharge below 18 volts.

9. **Protection:**

User accessible input (AC) and output fuses are provided.

- a) **Reverse polarity protection** - provided
- b) **Short circuit protection** - provided
- c) **Over-Voltage Protection** - provided
- d) **Over current protection** - provided
- e) **AC Surge Protection** - provided
- f) **Power on-off switch** - provided
- g) **Soft start and stop:** Starts and stops gradually.

No sudden in-rush of current. This protects both the batteries and any other circuits connected to the charger.

10. **De-sulfation of battery:** The charger will remove loose sulfation and increase the battery life. (Hard sulfation cannot be reversed).

11. **No current drain:**

No (zero) current is taken from the battery when connected to battery but AC not plugged in. (Many other chargers in the market draw 30-40 mAmp which drains the battery.)

12. **Reliability:**

a) **Mean Time between failures (MTBF):**

30,000 power-on-hours (POH) or greater. This translates into 10 years of everyday operation of 8 hours.

b) **Burn-in**: All chargers are burned in at an average DC load of 4 Amps.

13. **Electromagnetic Interference (EMI)**:

The charger will not generate excessive radiated or conducted emissions. No interference with TV, radio, computer or other equipment.

14. **Ground leakage current**:

The ground leakage current is 87 microAmp which complies with the requirements.

15. **Size**: **Very Small** Length - 6.9" (175 mm)
Width - 3.7" (94 mm)
Height - 1.9" (48 mm)

Very Light Weight 1.5 lbs (700 grams)

Very nice looking **metal case with black matte finish**.

Ref: Spec2408CAA.081500

CHARGING CURVE

MODEL 2408CAA
SONEIL 24V/4A CONSTANT CURRENT CHARGER

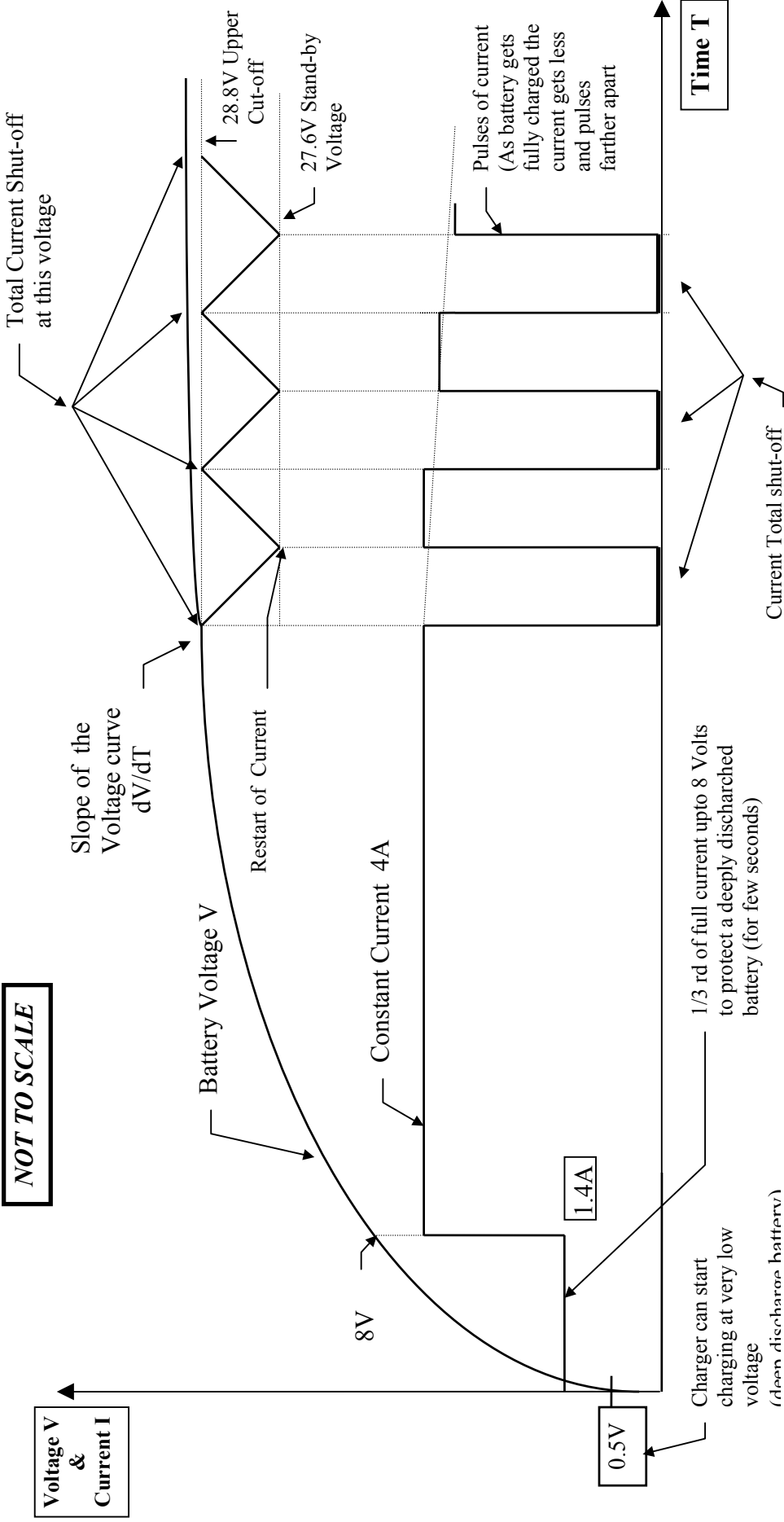

Ref.CurveCAA.020899

X00-8-905

OUTPUT CONNECTOR: (SEE REMARK A)



TYPE: A&C

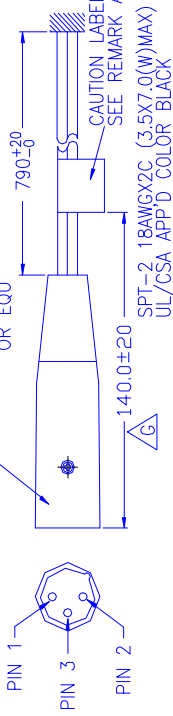

REMARK A:

P/N	TYPE	MODEL NAME	CONNECTOR & COLOR	WIRING	LABEL	POWER CORD	REMARK
506-2408-000	STD	STD_2408CAA	NONE	NONE	NONE	UL/CSA	
506-2408-00A	A	2408CBA	NEW TIDE 89M-101\3P COLOR BLACK	PIN 1=+VE PIN 2=-VE PIN 3=JUMPER FROM PIN 2	NONE	UL/CSA	
506-2408-00B	B	2408CBA	NEW TIDE 89M-101\3P COLOR SILVER	PIN 1=+VE PIN 2=-VE PIN 3=JUMPER FROM PIN 2	NONE	UK	CANCEL
506-2408-00C	C	2408CBA	NEW TIDE 89M-101\3P COLOR BLACK	PIN 1=-VE PIN 2=+VE PIN 3=JUMPER FROM PIN 1	YES	UL/CSA	

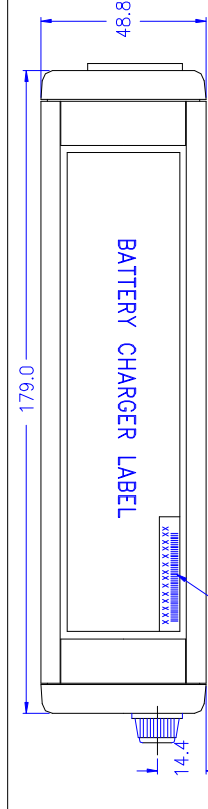

IN ALWAYS 0717-1(-S) OR EQU

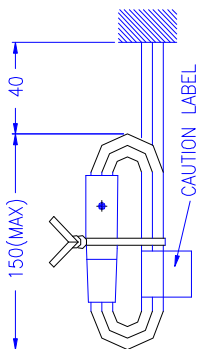
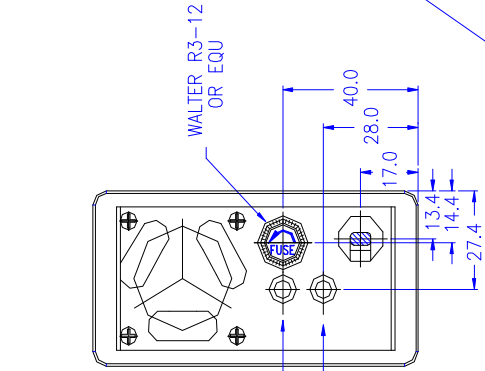
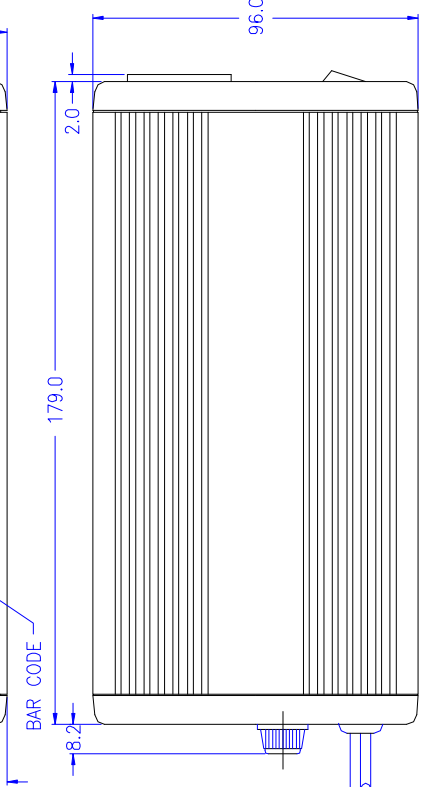
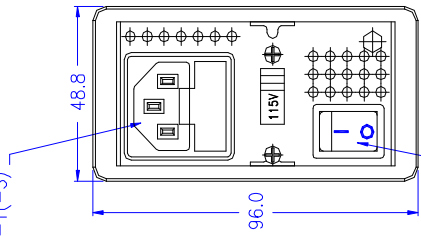

TYPE: A,B,C 綁線方式

CHARGE LED(GREEN+ORANGE)

POWER LED(RED)

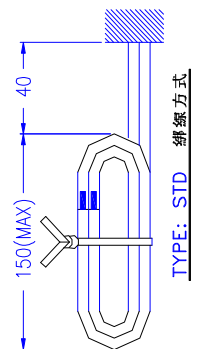

TYPE: STD 綁線方式

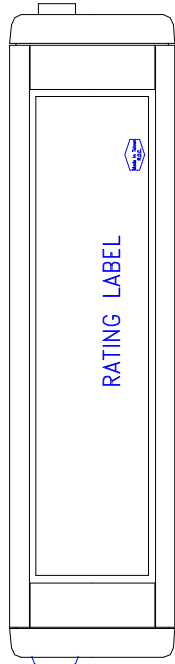

FILE: 2408CAA\CASE

SONEIL - MISSISSAUGA CANADA ONTARIO		SHEET 1	DF 1	R 0	G
UNIT	SCALE	TOLERANCE: UNLESS OTHERWISE SPECIFIED			
mm	1:1	±0.1	±0.2	±0.3	±0.5
DRAWN	DESIGNED	CHECKED	APP'VD	DATA	
				JUN.03.2002	

506-2408-00X
TITLE X=A OR C
2408CXA

ISSUE