

**POWERFILL SNORKEL**  
OPERATIONS MANUAL  
2024A



# POWERFILL SNORKEL MANUAL

Version 2024A

PLEASE READ BEFORE USING.

This manual is applicable to the following models:

# 012831	(BB1821 / BBX1821 / BB2024 / BBX2024 / BB2226 / BBX2226)
# 012832	(BB2732 / BBX2732)
# 012833	(BB3542 / BB420B / BBX3542)
# 012834	(BB4453)

Copies of this manual (#011947) are available from SEI.

The manual is available on the SEI website.

Register for manual update notifications at [bambiupdate@sei-ind.com](mailto:bambiupdate@sei-ind.com)

This manual is based on information that was available at the time it was printed and may not be applicable to products received before the issue date and customized items.

## SEI INDUSTRIES LTD.

7400 Wilson Avenue  
Delta, B.C. Canada  
V4G 1H3

Phone: (604) 946-3131

Fax: (604) 940-9566

E-Mail: [seisales@sei-ind.com](mailto:seisales@sei-ind.com)

Website: [www.bambibucket.com](http://www.bambibucket.com)

<b>Version</b>	<b>Release Date</b>	<b>Revision Summary</b>
2023A	17-Nov-2023	<ul style="list-style-type: none"><li>• General Revision</li></ul>
2024A	25-Mar-2024	<ul style="list-style-type: none"><li>• Changed recuperator to new connector design</li></ul>

# Table of Contents

<b>Section 1: Introduction</b> .....	<b>1</b>
Overview .....	1
<b>Section 2: Installation on Pre-Existing Buckets</b> .....	<b>3</b>
Snorkel Flange Kit Installation .....	3
<b>Section 3: Safety</b> .....	<b>13</b>
Pre-Flight Safety Check .....	13
<b>Section 4: Operations</b> .....	<b>15</b>
Operating the Powerfill Snorkel .....	15
<b>Section 5: Maintenance and Troubleshooting</b> .....	<b>17</b>
Maintenance Procedures .....	17
Troubleshooting Chart .....	18
Unscheduled Maintenance .....	19
<b>Section 6: Storage and Shipping</b> .....	<b>21</b>
Storage Procedures .....	21
Shipping Instructions .....	21
<b>Section 7: Specifications and Parts</b> .....	<b>23</b>
Capacity and Weight Specifications .....	23
Parts .....	24
<b>Section 8: Drawings</b> .....	<b>36</b>
<b>Section 9: Warranty</b> .....	<b>38</b>

# Section 1: Introduction

## Overview

This manual provides helicopter operators with information on the service and maintenance of the PowerFill Snorkel. This service manual also includes all parts lists and installation drawings.

For your own protection, and for longer bucket life, always read the instructions and warnings. Ignoring these warnings could result in personal injury, bucket damage, or aircraft damage.

SEI Industries Ltd. offers complete parts supply and repair services for the PowerFill Snorkel. For a repair facility in your area, please contact SEI. For maintenance and repair purposes, parts diagrams and descriptions are provided in this manual. When ordering parts, please provide the model and serial number of your Bambi Bucket.

For more copies of this manual, please contact SEI or visit our website at [www.bambibucket.com](http://www.bambibucket.com) for more information on these products.

## System Description

PowerFill Snorkel is a system which allows partial or complete bucket fills from a range of previously inaccessible water sources as shallow as 18" (0.46m). This includes streams, ponds, and low profile dip tanks. It is available for standard Bambi Bucket models 1821 to 4553, and Bambi MAX models 1821 to 3542.

The snorkel consists of an externally mounted pump and a flange assembly. The flange assembly is permanently installed into the bucket and includes a flapper check valve to prevent water from flowing back through the pump when the pump is not running. Multiple flanges can be installed on several buckets to accept the same pump unit.

The pump assembly is connected to the valve assembly with a camlock fitting which allows the pump to be quickly removed for ease of transport.



The PowerFill snorkel has an electrically driven pump with an optimum output of 425 USG/min (27 L/s). The pump requires a 28VDC power source capable of supplying 45A. This supply must be from the aircraft non-essential bus. The installation shall be done in accordance with FAA Advisory Circulars AC43.13-1B and AC43.13-2A and any applicable aircraft manufacturer's instructions. Refer to the Appendix of this manual for a wiring diagram.

### WARNING

Do not connect the PowerFill Snorkel system to any aircraft bus bar that is used for emergency or essential loads. Before installation, do an electrical load analysis to ensure that the generator capacity is adequate to operate the system and amend the aircraft electrical load to the new requirements.

## Section 1: PowerFill Snorkel Overview

---

Power is transmitted through a waterproof cable to the pump motor. At the top end of the cable, a quick disconnect plug will separate with minimal force in the event of a load jettison.

The pump motor, impeller and housings are contained within a circular steel filter basket. The filter basket serves to protect the components from impact damage while also acting as a debris screen.

The pump is fully waterproof in operation to a depth of 10 ft. (3.0 m) and can run “dry” without damage. It has a standard hydraulic grease nipple provision to extend the life of the motor output shaft seal.

The mating flange consists of two plates that clamp together over the bucket shell to form a hard point for quick mounting of the pump unit. The flange can be installed on several buckets to accept the same pump unit. Mounted to the inside of the flange, a one-way flapper valve prevents water from flowing back through the pump when the pump is not running. If the pump is not in use for a period of time, a blanking plate should be installed to replace the pump.

The PowerFill Snorkel system comes complete with wiring harness. An optional control box can also be ordered.

### **System Requirements**

- 28 VDC power supply
- 45 A continuous output for at least one minute
- Recommended circuit protection is 50 amps

### **Longline Wire Gauge Requirements**

When using a longline, care must be taken in selecting the correct gauge of cables. See the following chart for recommended longline wire sizes for the PowerFill Snorkel.

Wire Length		Wire Type	Connectors	
Feet	Meters		Top	Bottom
0–100	0–30	2 x #6 TEW	APP 6326G6	APP 6326G6
101–200	30–61	2 x #4 WELDING	APP 6326G6	APP 6326G6

## Section 2: Installation on Pre-Existing Buckets

### Snorkel Flange Kit Installation

This section's instructions apply only to pre-existing Bambi Bucket models 1821 to 4453 and Bambi MAX Bucket models 1821 to 3542. For installation instructions for new buckets, please see section 2 of this manual.

#### ***Introduction***

For existing Bambi Buckets that don't have the PowerFill Snorkel flange mounted, a flange must be permanently attached to the shell of the bucket. Once the flange has been installed, the pump may be attached or removed in minutes, as required. A blank plate is included with the flange installation kit to cover the flange hole when the pump is not attached.

The pump mating flange is located approximately midway up the bucket on the center, or front most panel, below the ballast. By mounting the flange in the center of the panel, tensile forces from the load bearing webbing straps are transferred through the flange via anchor plates secured by the flange bolt. A pattern is supplied to make the locating of the flange assembly simple.

The following detailed instructions are supplied to guide the operator through all the steps required for the installation of the flange. Please read the instructions and study the corresponding pictures to determine what tools and consumables you require, from the list supplied, before commencing work.

#### **NOTICE**

Operators who choose to deviate from the instructions supplied, must do so only with the approval of SEI Industries or risk voiding any warranties extended by SEI Industries.

## Section 3: Safety

---

### *Tools Required*

- Small hammer
- Soldering gun (to seal the edges of the holes) or 3/8" (9.5mm) diameter fabric punch
- Drill motor
- 3/16" drill
- 3/8" combination wrench
- 7/16" combination wrench
- Philips screwdriver #2
- Adjustable blade utility knife
- 1/4" Allan key
- 5/16" Allan key
- Scissors (sharp)
- Awl

### *Stripping Down the Bucket*

1. Pull the IDS up into its deployed position.
2. Find the strip that has the snorkel template on it.





### Section 3: Safety

---

3. Remove the ballast pouch or bars.



4. Remove IDS spoke from the shell brackets on each side of ballast.



5. Remove the cinch strap bracket (only on standard Bambi Buckets) from the panel.



6. Remove the lower IDS restrainer bracket.



## Section 3: Safety

---

7. Remove the bolts holding the wear strip.



8. Remove the fiberglass batten from the panel.



### ***Preparing the Bucket***

Support the inside of the shell with a thick piece of wood about 6" (150 mm) wide and up to 3' (1 m) long. Use stands or boxes to support the wood. This will push the panel out and give you a supported surface to work on.

### ***Cutting the Bucket***

1. Using a utility knife, cut along the centre line.



### Section 3: Safety

2. Cut a section of fabric from centre line to upper hole.



3. Cut the webbing along the centre line.

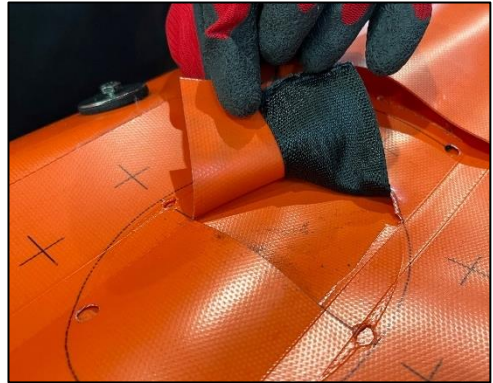

4. Cut fabric along the top line, be careful not to cut through the webbing. The use of a spacer between the fabric and webbing is recommended.



5. Using a screwdriver, pull the webbing through the cut.



### Section 3: Safety

6. Repeat for the bottom of the flange.



7. Cut out the snorkel hole along the marked line making sure to cut through both layers of fabric.



8. Place a block under the shell and use a fabric punch to punch the 8 holes in the shell (use a 3/8" drill if punch is not available).



9. Wrap webbing around anchor plate and position it over the hole in the shell. Use a soldering gun to burn a hole through webbing (use a 3/8" drill if soldering gun not available).

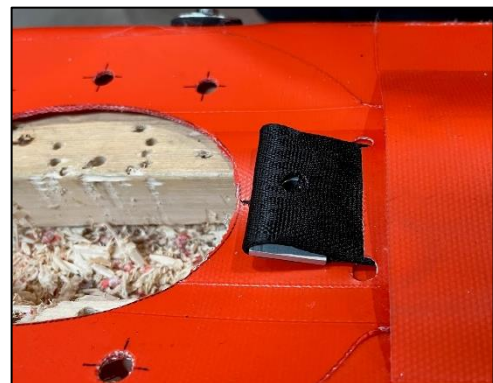

### Section 3: Safety

10. Use blowtorch or lighter to burn any frays on the ends of the webbing.



11. Repeat for both top and bottom webbing.



12. Install modified batten set into the shell underneath the webbing.

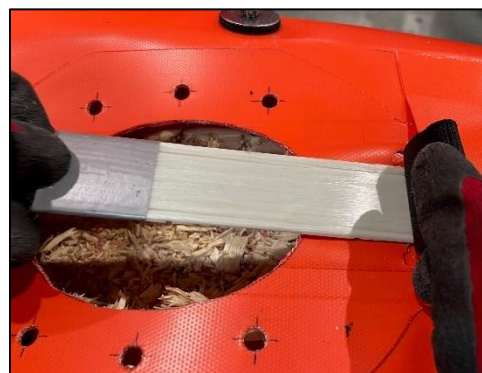

13. Drill 2 holes into battens through the holes in the shell for the wear strip and retainer bracket using a 3/16" drill.



### Section 3: Safety

14. Reinstall wear strip and restrainer bracket.



15. Reinstall bottom chain with lock wire.

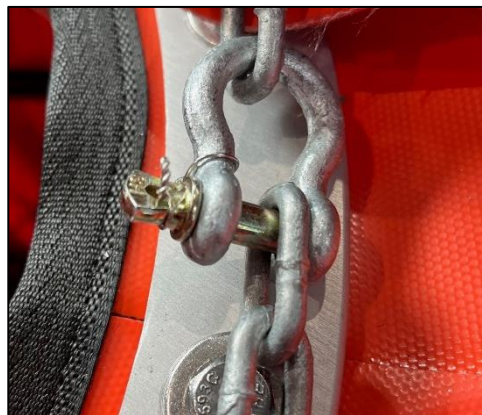

16. Cut a few inches of butyl tape and install along top and bottom groove of flange making sure to push tape in for a good seal.



17. Install flange with the backing plate and gasket using (4) 3/8-16 x 1 socket head screw and (4) 5/16-18 x 1 socket head screw.

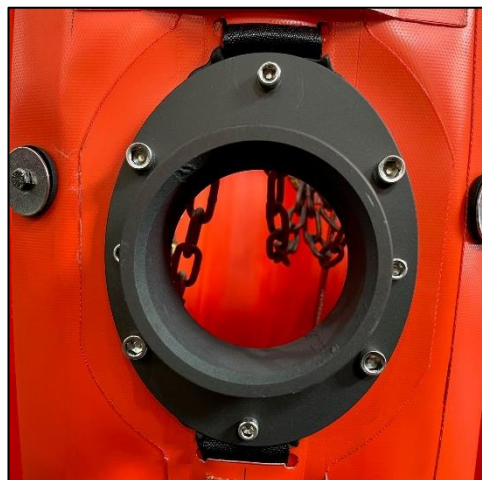

### Section 3: Safety

---

18. Install flapper valve assembly with 1/4-20 x 3/4 bolt, 1/4" lock washer, and 1/4 x 11/16 flat washer.

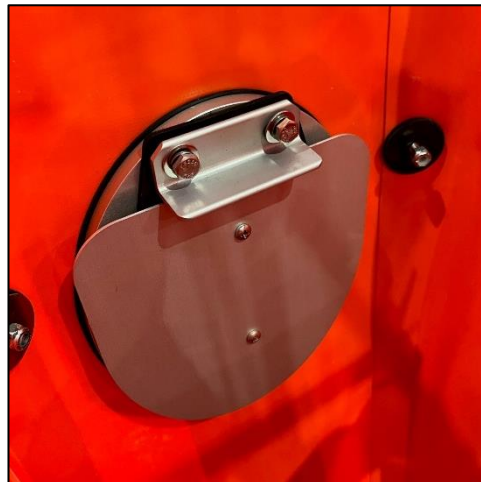

19. Reinstall ballast pouch and IDS spoke.

**THIS PAGE INTENTIONALLY LEFT BLANK**



## Section 3: Safety

---

# Section 3: Safety

## Pre-Flight Safety Check

In addition to performing the pre-flight check on the bucket, perform the following checks on the PowerFill Snorkel system:

1. Inspect the conductor wires for damage, chaffing, or wear. Confirm that the conductor cables are firmly secured.
  - The wires should be attached to the nearest suspension line.
  - If a long line is used, the wires should be attached to this line as well.

### CAUTION

Do not operate with damaged cables. Damage to an electrical cable, that leaves the conductor exposed, can result in a fire if it contacts another conductor or metal object.

2. Inspect the cable connectors for damage and ensure proper connections.
3. With power on, check the function of the pumps by pressing the pump's ON button for four or five seconds.
  - The pump should turn on and run for the period the button is held. The pump will be audible within a few feet of the bucket.
  - Listen for abnormal noises that are not consistent with smooth operation. If you are operating in a noisy environment, you can confirm that the pump is running by holding your hand on the top of the filter screen.
  - You may also see the shell move each time you activate the switch.

### CAUTION

Do not put your fingers or other objects into the pump impeller while the pump is running. Personal injury or damage to the pump can occur.

4. Check the filter screen for debris accumulation and clear as necessary.
5. Check the filter screen for signs of damage that may affect water flow.
6. Repair any damage to the components above before operating.

**THIS PAGE INTENTIONALLY LEFT BLANK**

## Section 4: Operations

### Operating the Powerfill Snorkel

Flying a Bambi Bucket with the PowerFill Snorkel will not adversely affect the flight characteristics of the bucket.

#### *Filling with the PowerFill Snorkel System*

To initiate a fill with PowerFill, the pump impeller must be immersed. It may not be possible to fill from water sources less than 18" (46cm) deep.

The further the bottom of the bucket can be lowered into the water source, the faster the bucket will fill. Where possible, employ a partial dip fill, augmented by the pump, to reduce the total fill time.

Operation is accomplished by pressing the fill button for as long as it takes to fill the bucket. Frothing of the water or slow fill rate indicates the pump is not submerged far enough to maintain prime.



#### **CAUTION**

Do not submerge the bucket to a depth of more than 20 feet (6 m) when performing conventional dip fills with PowerFill systems installed.

Do not operate PowerFill if the bucket is submerged to a depth of 10 feet (3 m) or more.

Once a fill has been started, the bucket will need to be supported by maintaining some tension on the suspension lines, particularly when the bucket is nearly full. If the bucket is not supported, the flexible nature of the bucket shell may allow it to collapse to one side as the water load increases.

Bucket Model	Optimal Fill Time
BB1821 / BBX1821	30s
BB2024 / BBX2024	34s
BB2226 / BBX2226	37s
BB2732 / BBX2732	45s
BB3542 / BBX3542	59s
BB4453	75s

If operating PowerFill in extremely dirty or swampy water sources, more frequent inspections of the pump impeller and screens may be required to maintain optimal function. The pump(s) can be run dry without damage.

THIS PAGE INTENTIONALLY LEFT BLANK

# Section 5: Maintenance and Troubleshooting

## Maintenance Procedures

In addition to the daily pre-flight inspections as outlined in *Section 4*, follow the weekly inspection procedure for times when the bucket is in continuous use.

### *Weekly Inspection*

1. Check all parts of the system for visible damage or defects.
2. Clean all debris from the pump motor impeller and debris screen.
3. Assess the function of the pump by running it.

### **CAUTION**

Disconnect power to the pump motor before performing visual inspection of pump impeller.

4. Inspect the pump impeller for signs of damage, particularly on the leading (lower) edge of the impeller blades.
5. Inspect the one-way flapper valve for cuts or tears.
6. Inspect the entire length of all electrical cables for damage. Immediately repair any damage to the conductor cable installation.
7. Ensure each cable connector is securely attached to its cable and free from cracks or damage.

### *Pump Output Shaft Lubrication*

The pump output shaft must be lubricated periodically to preserve the life of the seals. Good seal condition will prolong the life of the motor by preventing moisture and other contaminants from entering the motor case. Lubrication will require a hand pump grease gun with a standard hydraulic coupler.

### **CAUTION**

The lubrication of the pumps output shaft seals is critical to the longevity of the pump. Failure to follow the recommended lubrication intervals may result in premature pump failure.

After every 300 pump fill cycles:

1. Remove the three nuts securing the filter basket to the top mount ring and pull the filter basket free from the pump assembly.
2. Gently apply one to two pumps of grease to the grease nipple using enough to purge grease through the seal.
3. Check for dirt or gravel accumulation between the seal cup and the bottom shank of the impeller. Clean out any dirt and debris that may have accumulated inside the filter basket.
4. Re-install the filter basket.

## Section 5: Maintenance and Troubleshooting

### Troubleshooting Chart

Problem	Possible Cause	Check / Repair
Pump will not run when first connected.	Incorrect connection to power supply.	Re-check connections.
	Incompatible power supply.	Compare power supply output with requirements.
	Circuit breaker in the off position	Reset breaker to on position.
Pump fails to operate or suddenly stops in use.	Disconnected conductor cable.	Check all cable connections.
	Over-load current to motor.	Check motor.
	Debris jamming or clogging pump.	Remove debris.
Average bucket fill times increase over time.	Debris filter clogged.	Clean debris filter
	Pump impeller worn or damaged	Inspect and repair/replace pump impeller.
	Wear / damage to cable connections or cable.	Inspect, repair connectors, cable as required.
Pump noisy in operation.	Damaged pump assembly or impeller.	Inspect and repair / replace pump components as required.
	Debris in impeller housing.	Remove debris.
Excessive fill times when using longline.	Damaged cable.	Measure cable resistance to check for damage.
	Cables too small.	Compare cable sizes with recommended sizes

## Section 5: Maintenance and Troubleshooting

### Unscheduled Maintenance

#### Discharge Hose Replacement

1. Undo the upper hose clamp and work the hose from side to side while restraining the pump unit to remove the elbow from the discharge hose.
2. Remove the two bolts and nuts which secure the cone segments to the discharge hose. Remove the cone segments.
3. Undo the lower hose clamp and work the hose from side to side while restraining the pump unit to remove the discharge hose from the pump.
4. Apply soapy water or a small amount of petroleum jelly to the inside lip of the new hose to assist in getting the hose over the pump nipple. Use a round rod or screwdriver to help pry the hose onto the nipple.
5. Repeat the process for the elbow.
6. Check for proper alignment of the elbow and replace both hose clamps.
7. Replace the cone segments and hardware.

#### Carry on Tool Kit

It is always recommended that the following tools and supplies be kept with the PowerFill unit. This kit allows you to attach the PowerFill unit as needed.

*Plastic Tie Wraps  
(to secure power  
line to suspension  
lines).*

*1/4" Allan Key  
(to remove or  
attach PowerFill  
unit).*



*Four 3/8" x 1 1/2" NC  
head cap screw bolts  
(for attaching  
PowerFill unit).*

*7/32" Allan Key  
(to remove the  
blanking plate bolts).*

*Side Cutters  
(to trim tie wraps  
when installed).*

**THIS PAGE INTENTIONALLY LEFT BLANK**



# Section 6: Storage and Shipping

## Storage Procedures

No additional preparations for storage are required after performing the yearly maintenance procedures, as outline in *Section 6: Maintenance*. However, these points should be noted:

- If you are going to store the PowerFill unit for a period of time, it is recommended that the pump unit be cleaned, dried, and greased with one pump of the grease gun.
- It is recommended that the Bambi Bucket and PowerFill Snorkel system components are stored indoors when not in use. This will minimize deterioration due to temperature change, UV light, and atmospheric moisture.
- If the PowerFill Snorkel pump is to be put into storage for a long period of time, it is recommended to store it in a moderate temperature storage area and off the floor, on a shelf, to prevent moisture build up inside the motor from repeated changes in temperature.

## Shipping Instructions

If the Bambi Bucket is to be moved to a different site, the pump unit should be removed from the shell before shipping. Also, dry the pump and clean any debris from the filter screen before shipping.

**THIS PAGE INTENTIONALLY LEFT BLANK**

## Section 7: Specifications and Parts

### Capacity and Weight Specifications

Capacities and weights are accurate within 5%. Specifications are subject to change.

#### ***Bambi Bucket with PowerFill Snorkel***

Model	Capacity			Fill Time	Empty Weight		Gross Weight	
	Imp Gal	US Gal	Liters	Sec.	lb	kg	lb	kg
BB1821	180	216	820	30	138	63	1940	880
BB1821S	180	216	820	30	138	63	1940	880
BB2024	200	240	910	34	180	82	2180	990
BB2024S	200	240	910	34	177	80	2180	990
BB2226	220	260	1000	38	178	81	2380	1080
BB2732	270	320	1230	45	187	85	2890	1310
BB2732S	270	320	1230	45	183	83	2880	1310
BB3542	350	420	1590	59	195	89	3700	1680
BB420B	350	420	1590	59	193	87	3690	1670
BB4453	440	530	2000	75	226	102	4630	2100

#### ***Bambi MAX Bucket with PowerFill Snorkel***

Model	Capacity			Fill Time	Empty Weight		Gross Weight	
	Imp Gal	US Gal	Liters	Sec.	lb	kg	lb	kg
BBX2024	200	240	910	34	190	86	2190	990
BBX2226	220	260	1000	38	188	85	2390	1080
BBX2732	270	320	1230	45	198	90	2900	1310
BBX3542	350	420	1590	59	205	93	3710	1680

## Parts

### *Discharge Hose Assembly*

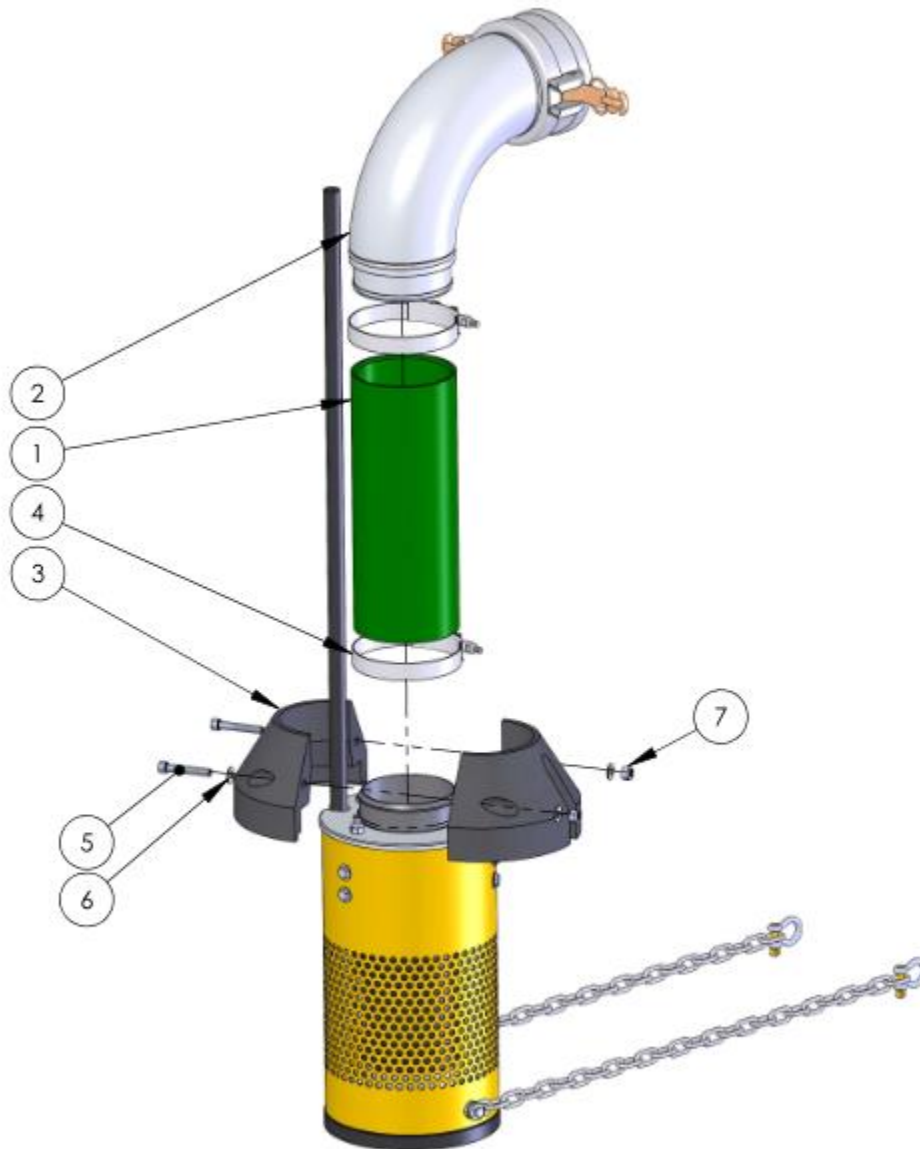

## Section 7: Specifications and Parts

### Discharge Hose Assembly (continued)

ITEM	MODEL	PART #	DESCRIPTION	QTY
1	BB1821	001079	HOSE, DISCHARGE, PF2	1
	BBX1821			
	BB2024			
	BBX2024			
	BB2226			
	BBX2226	001081		
	BB2732			
	BBX2732			
	BB3542	001082		
	BBX3542			
BB4453				
2	ALL	011196	ELBOW, 4", CAMLOCK, FABN	1
3		006413	CONE, SEGMENT	2
4		003060	CLAMP, T-BOLT, 4.5", SS	2
5		006516	SCREW, 5/16-18 x 2, SC, SS	2
6		006702	WASHER, FLAT, 0.34 x 0.69 x 0.08, SS	4
7		001664	NUT, HEX, NYLOCK, 5/16-18, SS	2

## Section 7: Specifications and Parts

### Recuperator

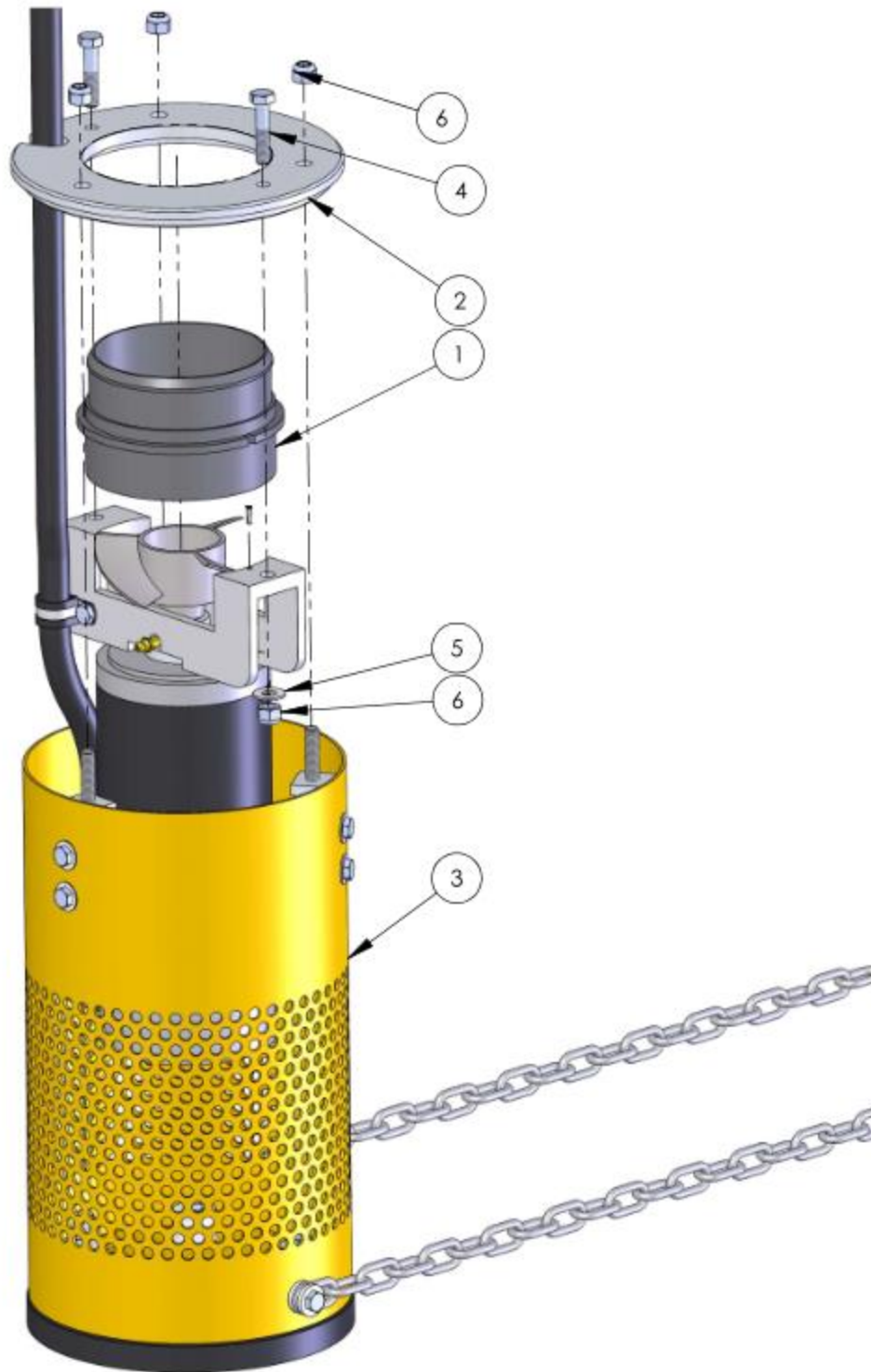

## Section 7: Specifications and Parts

---

### *Recuperator (continued)*

ITEM	MODEL	PART #	DESCRIPTION	QTY
1	ALL	018877	CONNECTOR, HOSE, PF2	1
2		001084	RING, MOUNT, FILTER, PF2	1
3	ALL	018640	BASKET, ASSY	1
4	ALL	000388	BOLT, HEX, 5/16-18 x 1-1/2, SS	2
5		000068	WASHER, FLAT, 0.34 x 0.75 x 0.047, SS	2
6		001664	NUT, HEX, 5/16-18, SS	5

## Section 7: Specifications and Parts

### Filter Basket Assembly

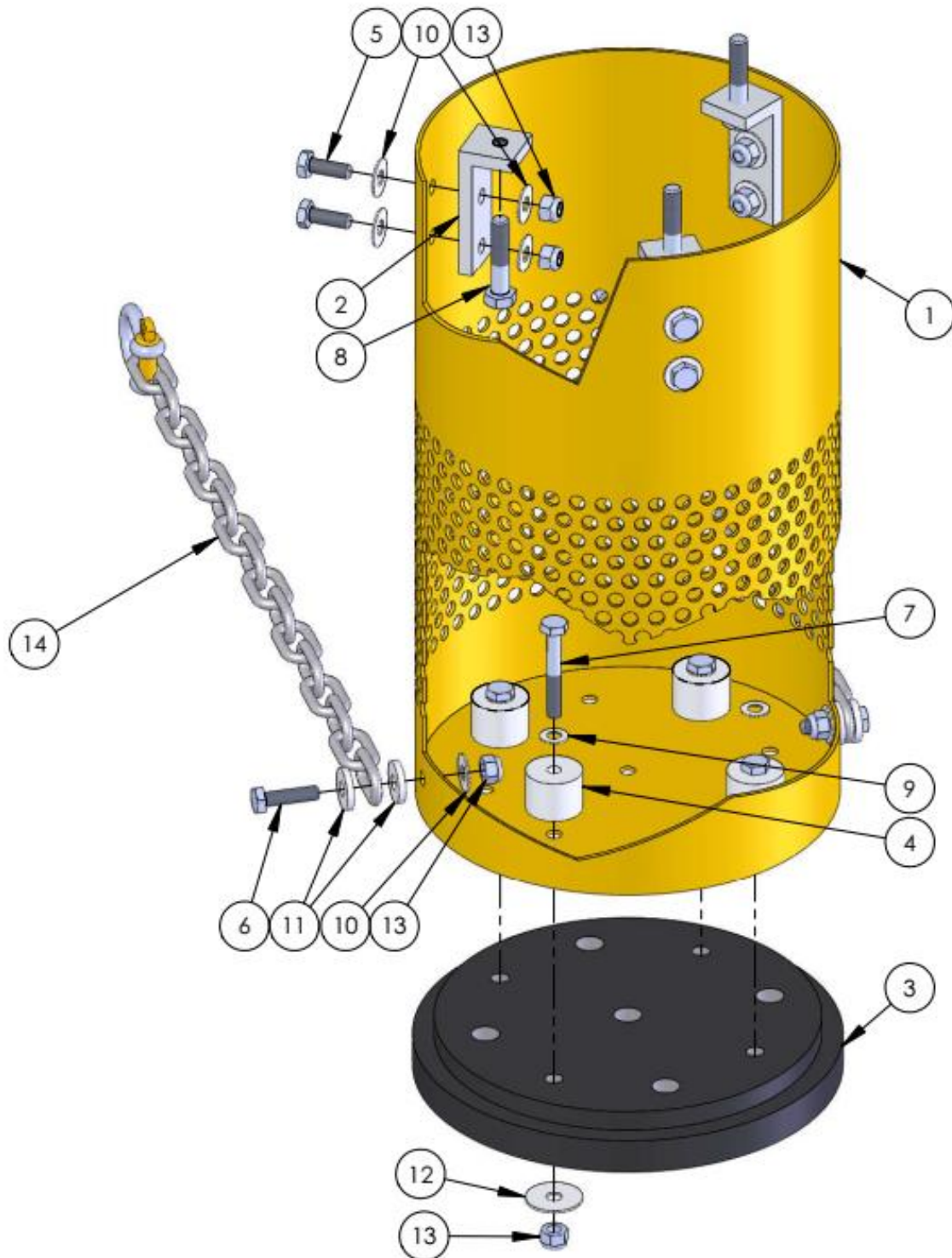



## Section 7: Specifications and Parts

### Filter Basket Assembly (continued)

ITEM	MODEL	PART #	DESCRIPTION	QTY
1	ALL	005208	BASKET, FILTER, PF2	1
2		001087	BRACKET, MOUNT, FILTERBASKET, PF2	3
3		001088	BLOCK, BUMPER, PUMP, PF2	1
4		001652	SPACER, 1/4" x 5/8" NYLON	4
5		000369	BOLT, HEX, 1/4-20 x 3/4, SS	6
6		000370	BOLT, HEX, 1/4-20 x 1, SS	2
7		000376	BOLT, HEX, 1/4-20 x 1-1/2, SS	4
8		000388	BOLT, HEX, 5/16-18 x 1-1/2, SS	3
9		001838	WASHER, FLAT, 0.27 x 0.50 x 0.032, SS	4
10		001833	WASHER, FLAT, 0.28 x 0.69 x 0.036, SS	14
11		001834	WASHER, FLAT, 0.28 x 0.75 x 0.125, SS	4
12		001858	WASHER, FLAT, 0.28 x 1.00 x 0.047, SS	4
13		001662	NUT, HEX, NYLOCK, 1/4-20, SS	12
14	BB1821	015924	CHAIN, STABILIZER	2
	BBX1821			
	BB2024			
	BBX2024			
	BB2226			
	BBX2226	015925		
	BB2732			
	BBX2732			
	BB3542	015926		
	BBX3542			
BB4453	015927			

## Section 7: Specifications and Parts

### Motor Assembly

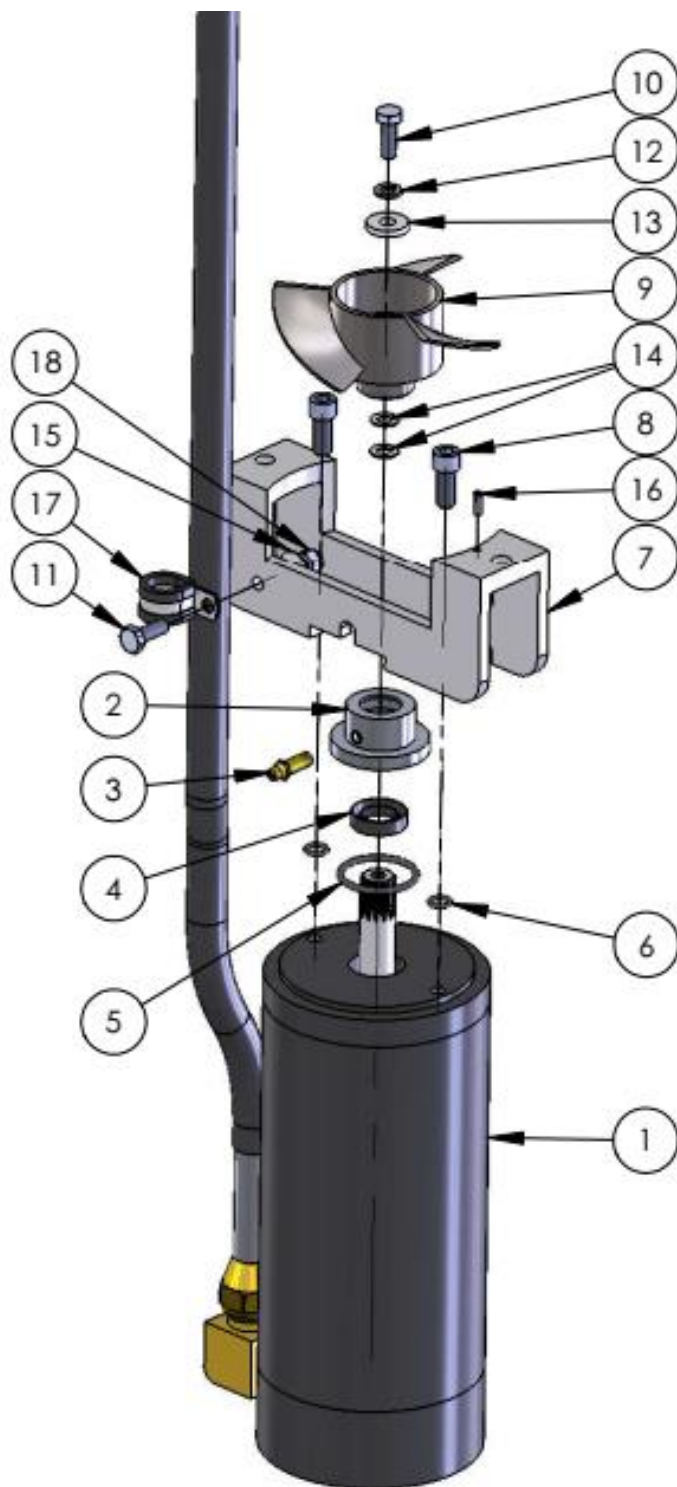

## Section 7: Specifications and Parts

---

### Motor Assembly (continued)

ITEM	MODEL	PART #	DESCRIPTION	QTY
1	ALL	006230	MOTOR, PF2, ASSEMBLY	1
2		001059	CUP, SEAL, MOTOR	1
3		005175	FITTING, GREASE, 1/4-28 x 15/16	1
4		006228	SEAL, LIP, 5/8 x 25 x 1/4	1
5		001890	O-RING, BUNA N, #124	1
6		007995	O-RING, BUNA N, #011, 50A	2
7		005207	ADAPTER, MOTOR, PF2	1
8		015794	SCREW, SC, 5/16-18 x 3/4, SS	2
9		005734	IMPELLER, CAST, SS, 4", #3	1
10		000533	BOLT, HEX, 1/4-28 x 3/4, SS	1
11		000369	BOLT, HEX, 1/4-20 x 3/4, SS	1
12		001852	WASHER, LOCK, SPLIT, 1/4, SS	1
13		001834	WASHER, FLAT, 0.28 x 0.75 x 1.125, SS	1
14		001838	WASHER, FLAT, 0.27 x 0.50 x 0.032, SS	2
15		001833	WASHER, FLAT, 0.28 x 0.69 x 0.036, SS	1
16		001734	PIN, SPLIT, 1/8 x 3/8, SS	1
17		002957	CLAMP, CABLE, 5/8"	1
18		001662	NUT, HEX, NYLOCK, 1/4-20, SS	1

## Section 7: Specifications and Parts

### Flange Installation Kit

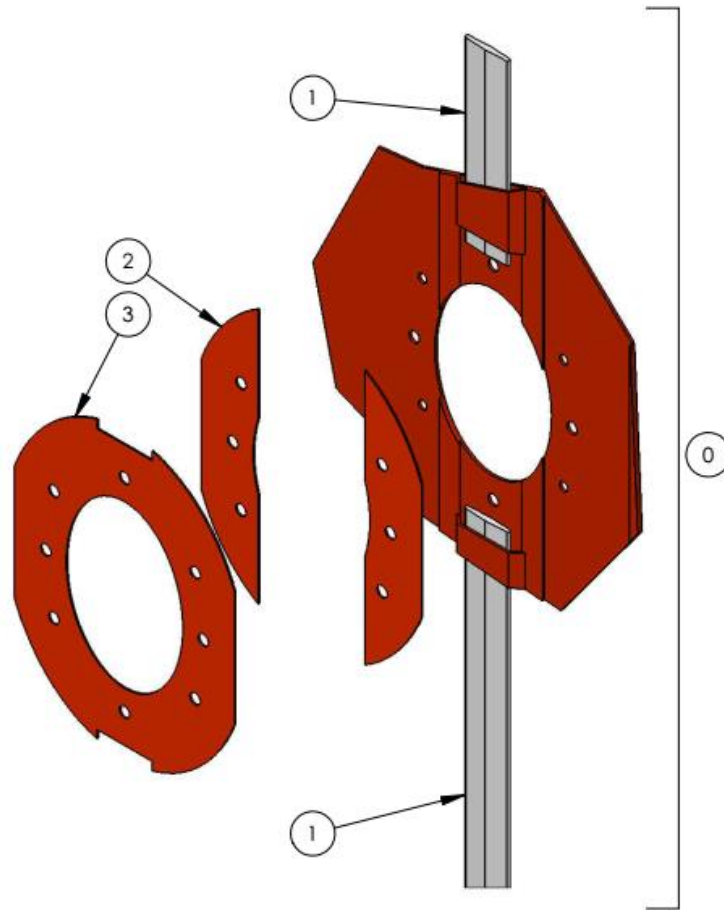

ITEM	MODEL	PART #	DESCRIPTION	QTY
0	BB1821	013642	INSTALL, POWERFILL, KIT	1
	BBX1821			
	BB2024	013019		
	BBX2024			
	BB2226			
	BBX2226	013020		
	BB2732			
	BBX2732	013023		
	BB3542			
	BBX3542	013024		
	BB4453			

## Section 7: Specifications and Parts

### Flange Installation Kit (continued)

ITEM	MODEL	PART #	DESCRIPTION	QTY
1	BB1821	016060	BATTEN, ASSY	1
	BBX1821			
	BB2024	006490		
	BBX2024			
	BB2226			
	BBX2226	006617		
	BB2732			
	BBX2732			
	BB3542	006621		
	BBX3542			
BB4453	007669			
2	BB1821	006622	SPACER, SHELL, PF2	2
	BBX1821			
	BB2024	006625		
	BBX2024			
	BB2226			
	BBX2226			
	BB2732			
	BBX2732			
	BB3542			
	BBX3542			
	BB4453			
3	BB1821		006325	DOUBLER, SHELL, PF2
	BBX1821			
	BB2024	006326		
	BBX2024			
	BB2226			
	BBX2226			
	BB2732			
	BBX2732			
	BB3542			
	BBX3542			
	BB4453			

## Section 7: Specifications and Parts

### Camlock Flange Assembly

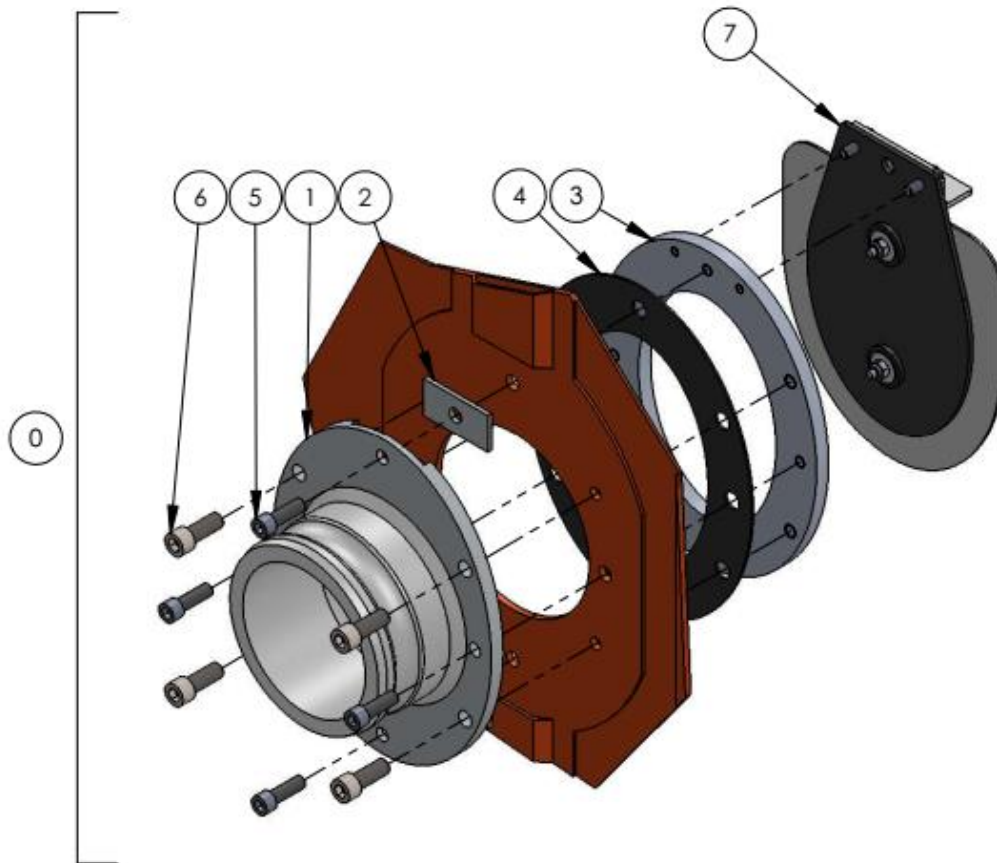

ITEM	MODEL	PART #	DESCRIPTION	QTY
0	ALL	012840	FLANGE, SNORKEL, CAMLOCK, ASSY	1
1	ALL	011197	FLANGE, 4", CAMLOCK, FABN	1
2		001074	PLATE, ANCHOR, PF2	2
3		001075	FLANGER, INNER, PF2	1
4		001078	GASKET, FLANGE, PF2	1
5		000432	SCREW, SC, 5/16-18 x 1, SS	4
6		009097	SCREW, SC, 5/16-18 x 1, SS	4
7		005737	VALVE, FLAPPER, ASSY	1

## Section 7: Specifications and Parts

### Flapper Valve Assembly

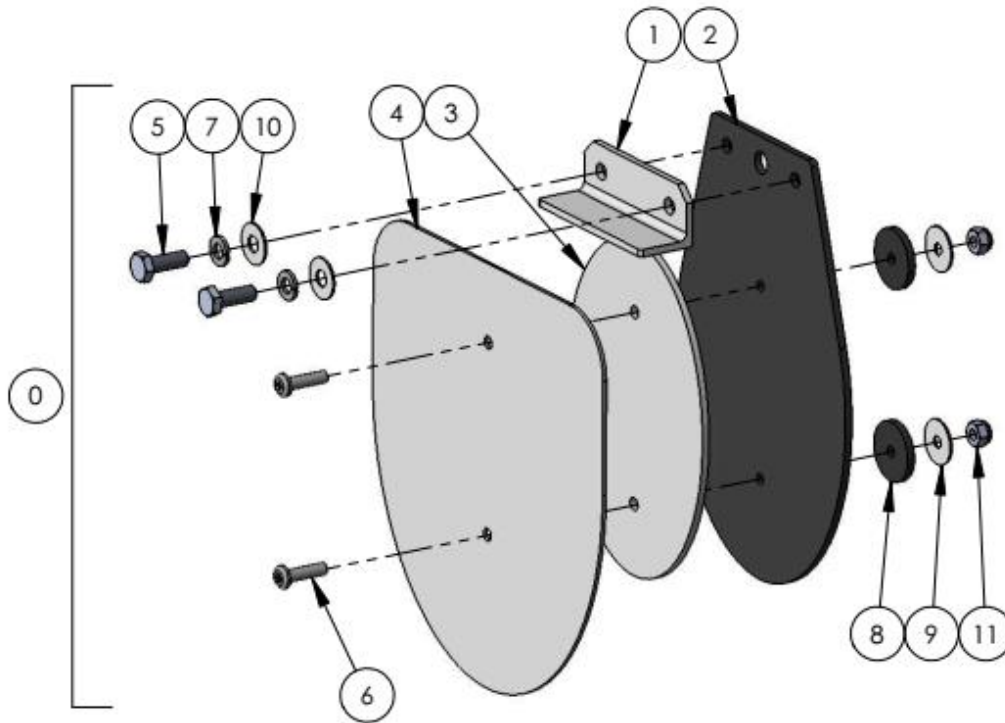

ITEM	MODEL	PART #	DESCRIPTION	QTY
0	ALL	005737	VALVE, FLAPPER, ASSY	1
1	ALL	001070	BRACKET, VALVE, FLAPPER, PF2	1
2		001071	VALVE, FLAPPER, PF2	1
3		001072	SPACER, VALVE, FLAPPER, PF2	1
4		001073	DEFLECTOR, VALVE, FLAPPER, PF2	1
5		000369	BOLT, HEX, 1/2-20 x 3/4, SS	2
6		000495	SCREW, PNP, 10-24 x 3/4, SS	2
7		001852	WASHER, LOCK, SPLIT, 1/4, SS	2
8		001824	WASHER, FLAT, 3/16 x 1 x 1/8, NEO	2
9		001855	WASHER, FLAT, 0.20 x 0.75 x 0.036, SS	2
10		001833	WASHER, FLAT, 0.28 x 0.69 x 0.036, SS	2
11		001660	NUT, HEX, NYLOCK, 10-24, SS	2

# Section 8: Drawings

## Wiring Diagram

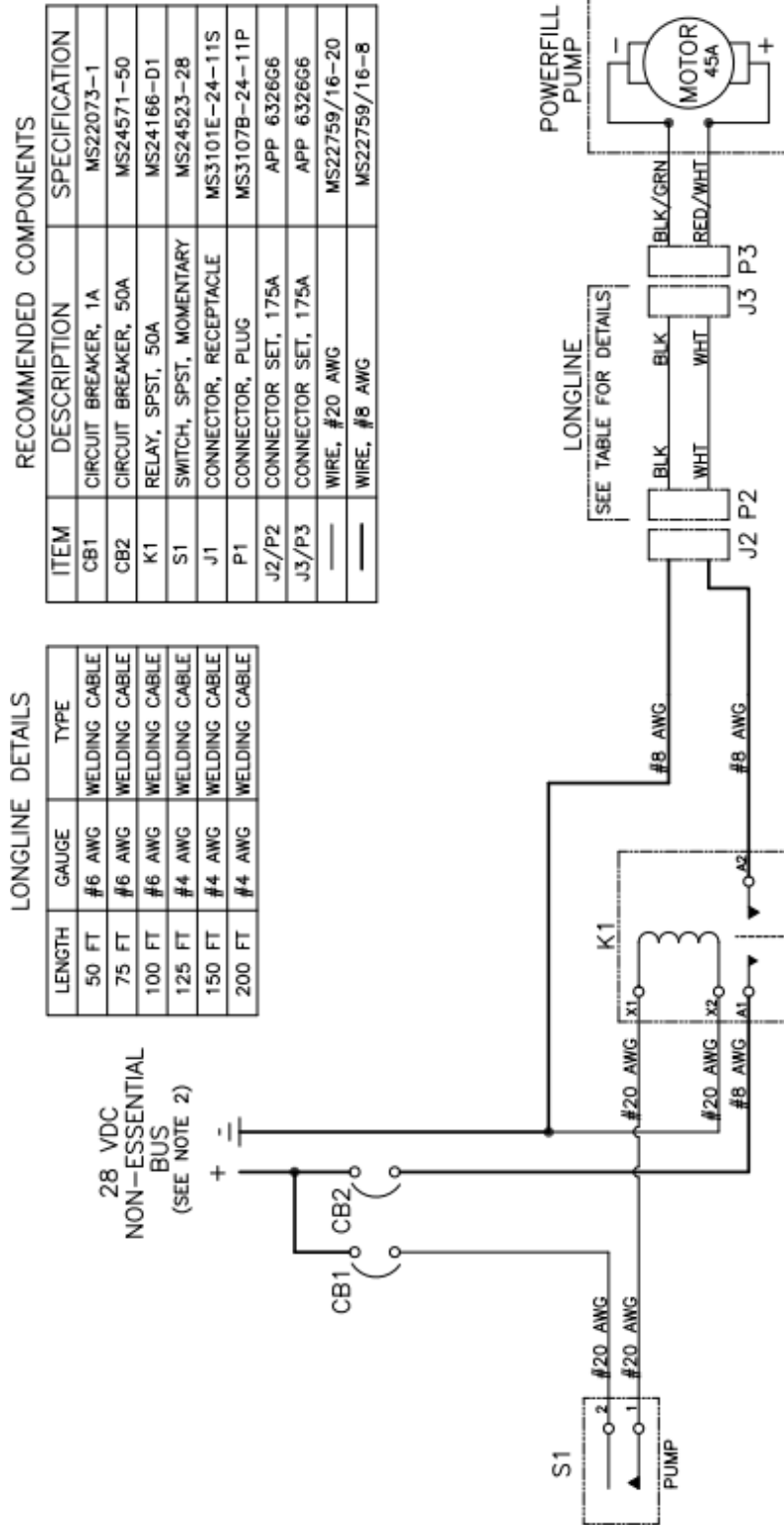

RECOMMENDED COMPONENTS

ITEM	DESCRIPTION	SPECIFICATION
CB1	CIRCUIT BREAKER, 1A	MS22073-1
CB2	CIRCUIT BREAKER, 50A	MS24571-50
K1	RELAY, SPST, 50A	MS24166-D1
S1	SWITCH, SPST, MOMENTARY	MS24523-28
J1	CONNECTOR, RECEPTACLE	MS3101E-24-11S
P1	CONNECTOR, PLUG	MS3107B-24-11P
J2/P2	CONNECTOR SET, 175A	APP 6326G6
J3/P3	CONNECTOR SET, 175A	APP 6326G6
---	WIRE, #20 AWG	MS22759/16-20
---	WIRE, #8 AWG	MS22759/16-8

LONGLINE DETAILS

LENGTH	GAUGE	TYPE
50 FT	#6 AWG	WELDING CABLE
75 FT	#6 AWG	WELDING CABLE
100 FT	#6 AWG	WELDING CABLE
125 FT	#4 AWG	WELDING CABLE
150 FT	#4 AWG	WELDING CABLE
200 FT	#4 AWG	WELDING CABLE

**NOTES:**

1. THESE ARE RECOMMENDED INSTALLATION INSTRUCTIONS ONLY. ALL INSTALLATIONS TO BE DONE BY QUALIFIED PERSONNEL IN ACCORDANCE WITH APPLICABLE LOCAL REGULATIONS.
2. CONNECTION TO AIRCRAFT POWER SUPPLY DONE IN ACCORDANCE WITH LOCAL REGULATIONS. DO NOT CONNECT THE POWERFILL SYSTEM TO ANY AIRCRAFT BUS BAR THAT IS USED FOR EMERGENCY OR ESSENTIAL LOADS. AMMEND THE AIRCRAFT ELECTRICAL LOAD ANALYSIS TO ENSURE THAT THE GENERATOR CAPACITY IS ADEQUATE TO OPERATE THE SYSTEM.
3. ALL GROUNDS, SOLDERED TERMINALS, AND CRIMPED TERMINALS DONE IN ACCORDANCE WITH AIRCRAFT MANUFACTURERS INSTRUCTIONS.



THIS PAGE INTENTIONALLY LEFT BLANK

## Section 9: Warranty

---

### Section 9: Warranty

SEI Industries Ltd. (the company) agrees to grant a warranty for a period of one year from the date of purchase of Bambi Bucket systems on the following conditions:

- a) The company's sole obligation under this warranty is limited to repairing or replacing, at the company's sole discretion, any product shown to be defective.
- b) The company's products are not guaranteed for any specific length of time or measure of service, but are warranted only to be free from defects in workmanship and material for a period of one year to the original purchaser.
- c) To the extent allowable under applicable law, the company's liability for consequential and incidental damages is expressly disclaimed. **The company's liability in all events is limited to and shall not exceed, the purchase price paid.**
- d) This warranty is granted to the original purchaser of Bambi Bucket systems and does not extend to a subsequent purchaser or assignee.
- e) The company must receive notification in writing of any claims of warranty from the original purchaser which must give details of the claimed defect in the product.
- f) Where the original purchaser is claiming under warranty, the product must be returned to the company for inspection with all transportation and duty charges prepaid.
- g) The warranty does not extend to any product that has been accidentally damaged, abraded, altered, punctured, abused, misused or used for a purpose which has not been approved by the company.
- h) This warranty does not apply to any accessories used with the product that are not supplied by the company and any warranty on such accessories must be requested from the manufacturer or dealer of the accessories.
- i) In the event the original purchaser does not give notice of a warranty claim, within one year of the original purchase of the product, it is understood that the purchaser has waived the claim for warranty and the purchaser and/or any subsequent purchaser must accept the condition of the product, without warranty.
- j) Any technical information supplied by the company regarding the product is not a condition of warranty but rather is information provided by the company to the best of its knowledge.
- k) There are no implied warranties nor is there any warranty that can be assumed from any representation of any person, except the company itself.

#### **Exclusions**

- l) This warranty is void if the product is not installed, used and/or maintained in accordance with the operations manual supplied by SEI.
- m) All Bambi Buckets are designed and manufactured with substantial safety margins. It is the responsibility of the user to ensure that the bucket is maintained to a safe standard.