

SEI
INDUSTRIES



Bambi
BUCKET®
Driven by Innovation



Bambi

MAX

BAMBI MAX
(1518-3542 MODELS)
SERVICE
MANUAL

2016 VERSION E

**BAMBI MAX SERVICE MANUAL - Models 1518-3542
Version E**

Issue Date: January 2017

PLEASE READ BEFORE USING.

SEI INDUSTRIES LTD.

7400 Wilson Avenue
Delta, B.C. Canada
V4G 1H3

Phone: (604) 946-3131

Fax: (604) 940-9566

E-Mail: seisales@sei-ind.com

Website: www.sei-ind.com

USA Patent # 9,265,977
Australia Patent AU2012201273
Canada Patent Pending

COPYRIGHT © 2016 SEI INDUSTRIES LTD. ALL RIGHTS RESERVED



We Engineer Solutions

2016 Bambi MAX Service Manual – Models 1518-3542 (Version E)

Table of Contents

Section 1: Introduction	1
Bambi MAX (Models 1518–3542)	1
Valve System	2
System Overview	2
System Description	2
Section 2: Deploying the Bambi MAX	6
Deployment Instructions	6
Attaching to the Cargo Hook	6
Connecting Power	8
Using Longlines	9
Instant Deployment System (IDS)	12
Section 3: Using Accessories	13
Using the PowerFill System	13
System Overview	13
System Description	13
Flying with the PowerFill Snorkel System	14
Filling the Bambi Bucket with the PowerFill Snorkel System	14
Using Foam	16
Sacksafoam Foam Injection System	16
Compatible Bambi MAX/Sacksafoam Models	17
Section 4: Making Adjustments	18
Adjusting Components	18
Valve Adjustment	18
Section 5: Packing and Storage	20
Packing and Storing	20
Packing the Bucket	20
Storing the Bambi MAX	24
Section 6: Troubleshooting and Maintenance	25
Troubleshooting	25
Valve Troubleshooting	25
Checking Aircraft / Longline Wiring	26
PowerFill Snorkel Troubleshooting	27
Maintenance Procedures	28
Bambi Bucket Weekly Inspection Checklist	28
PowerFill Weekly Inspection Checklist	28
Pump Output Shaft Lubrication	29
Grease Procedure	29
Unscheduled Maintenance	30
Unscheduled PowerFill Maintenance Procedures	30

Section 7: Valve Maintenance	31
Bambi MAX Valve Repair and Replacement	31
<i>Linkage Adjustment</i>	31
<i>Valve Removal</i>	31
<i>Installing the Valve</i>	33
<i>Bambi MAX Seal Replacement</i>	34
<i>Drive Cable Replacement</i>	40
<i>Changing the Guide Bushings</i>	45
Section 8: Repair Quick Guide	46
Overview of Repair Categories	46
<i>Category 1: Safety</i>	46
<i>Category 2: Operational</i>	46
<i>Category 3: Monitor</i>	46
<i>Category 4: OKAY</i>	46
Bucket Shell Repair Criteria	47
Cables Repair Criteria	48
IDS Hub Repair Criteria	49
M-Straps and Top Chains Repair Criteria	50
Control Head Repair Criteria	51
Section 9: General Repairs	52
Repair Instructions	52
<i>Suspension Line Replacement</i>	52
<i>M-Strap Replacement</i>	53
<i>Removing Old M-Straps</i>	54
<i>Installing New M-Straps (Short)</i>	55
<i>Installing New M-Straps (Long)</i>	57
<i>Bottom Loop Repairs</i>	59
<i>Bucket Patching</i>	59
<i>IDS Hub/Spokes Replacement</i>	60
Bambi MAX Shell Repairs	62
<i>Repair Failures</i>	62
<i>Repairing in High Humidity</i>	63
<i>Making Temporary Repairs with Sealing Clamps</i>	64
Temporary Repairs Using Glue	66
<i>Applying the Glue</i>	66
<i>Gluing with Patches</i>	67
<i>Cutting the Patch</i>	68
<i>Applying the Patch</i>	68
Hot Air Gun Patching	70
<i>Hot Air Gun Procedure</i>	71
Repair Kits	72
<i>Repair Kit Parts Table</i>	72
<i>Optional Supplies</i>	72

Section 10: Specifications and Parts **73**

Capacity and Weight Specifications	73
<i>Bambi MAX Capacity and Weight Chart</i>	73
<i>Bambi Max with PowerFill Snorkel Capacity and Weight Chart</i>	73
Parts Listings	74
<i>Bambi MAX Valve 16" Shell Assembly</i>	74
<i>Bambi MAX Valve 16" Valve Installation</i>	75
<i>Bambi MAX Valve 16" Seals</i>	76
<i>Bambi MAX Valve 16" Actuator and Controller</i>	77
<i>Bambi MAX Valve 16" Actuator</i>	78
<i>Bambi MAX Valve 16" Actuator 2</i>	79
<i>Bambi MAX Valve 16" Sheave Bar and Guide Rods</i>	80
<i>Bambi MAX Valve 16" Lift Bar and Linkage</i>	81
<i>Bambi MAX Valve 16" Lift Bar</i>	82
<i>Bambi MAX Head</i>	83
<i>Bambi MAX Shell, Models 1518-1821</i>	84
<i>Bambi MAX Shell, Models 2024-3542</i>	85
<i>Bambi MAX Shell, Models 2024-3542 (continued)</i>	86
<i>Rigging, Models 1518-1821</i>	87
<i>Rigging, Models 2024-3542</i>	88
<i>Rigging, Models 2024-3542 (continued)</i>	89
<i>IDS System, Model 1518-1821</i>	90
<i>IDS System, Model 1518-1821 (continued)</i>	91
<i>IDS System, Models 2024-3542</i>	92
<i>IDS System, Models 2024-3542 (continued)</i>	93
<i>Ballast Systems, Models 1518</i>	94
<i>Ballast Systems, Models 1821-3542</i>	95
<i>PowerFill Snorkel Drawing</i>	97
<i>Filter Basket Assembly</i>	98
<i>Motor Assembly</i>	100
<i>Recuperator</i>	102
<i>Discharge Hose Assembly</i>	104
<i>Flapper Valve Assembly</i>	106
<i>Flange Assembly for Shell</i>	107
<i>Bambi MAX Carrying Bags</i>	108
<i>Troubleshooter Kit</i>	108

Section 11: Warranty **109**

Appendix: Drawings **110**

<i>Pilot Controls</i>	110
<i>Pilot Controls, US Interagency</i>	111
<i>Crew Controls (using remote power supply)</i>	112
<i>PowerFill Pump</i>	113

Section 1: Introduction

Bambi MAX (Models 1518–3542)

This manual provides helicopter operators with information on the service and maintenance of the Bambi MAX. This service manual also includes all parts lists and installation drawings. For your own protection, and for longer bucket life, always read the instructions and warnings. Ignoring these warnings could result in personal injury, bucket damage or aircraft damage.

SEI Industries Ltd. offers complete parts supply and repair services for the Bambi MAX. For a repair facility in your area, please contact SEI. For maintenance and repair purposes, parts diagrams and descriptions are provided in this manual. When ordering parts, please provide the model and serial number of your Bambi MAX.

There are several models of Bambi MAX's available from SEI Industries. In addition, a number of accessories and enhancements are also available including the Bambi Power Pack with hand grip, Sacksafoam, Firesock and Marine Recovery Device. For more copies of this manual, please contact SEI or visit our website at www.bambibucket.com for more information on these products.



Bambi MAX inside bucket showing shell serial number plate.



Valve showing serial number location.

Valve System

System Overview

The Bambi MAX uses a tubular type valve with seals located on the top and bottom of the tube. When in the default closed position, the seals make contact with top plate and bottom ring of the valve assembly. When in the open position, the tube is raised allowing water to flow between the bottom of the tube and the base ring and then through the opening in the base ring.

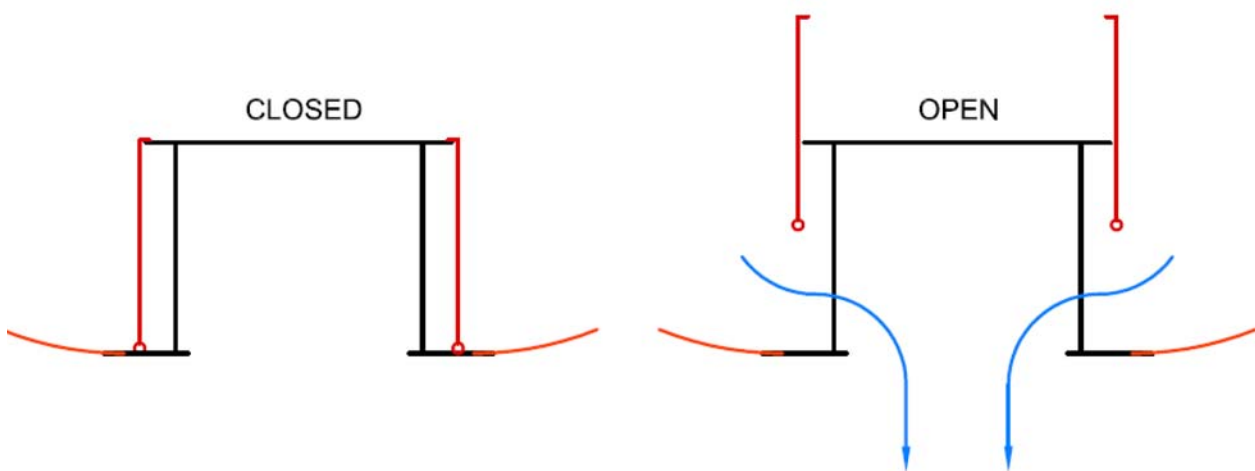

System Description

Movement of the valve tube is controlled by an actuator and drive cable system. The actuator is mounted on the top plate and consists of a drive motor, reduction gearing and a cable drum. The cable drum can be rotated clockwise or counter-clockwise depending on the direction of the motor.

One end of the drive cable is attached to the cable drum. The cable is routed down around the deflector sheaves at the base of the valve and back up to the cable drum where the other end is terminated forming a closed loop. The drive cable is also attached to a horizontal lift bar which itself is attached across the lower end of the tube.

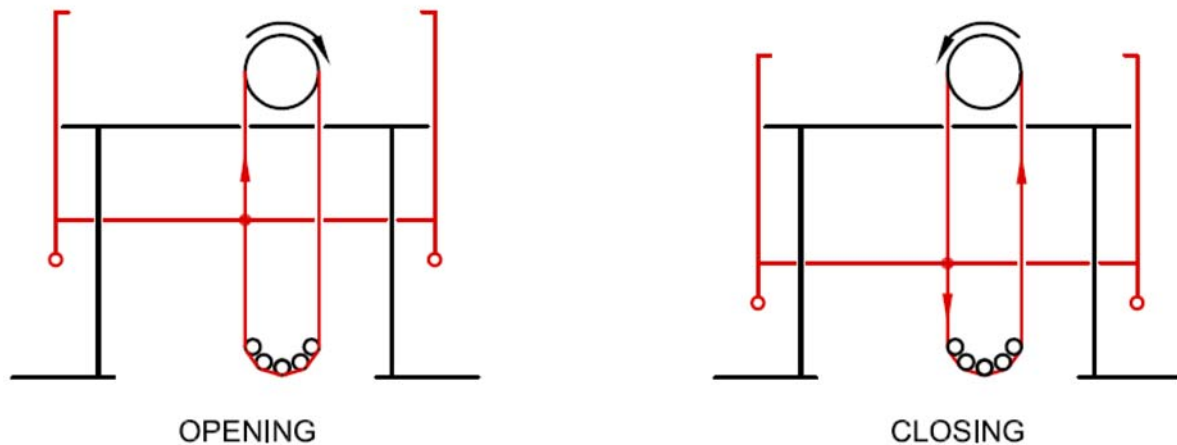

When the motor and cable drum is rotated clockwise, the drive cable pulls up on the lift bar, opening the valve. When the motor and cable drum is rotated counter-clockwise, the other end of the drive cable pulls down on the lift bar via the deflector sheaves, closing the valve. It is normal for there to be slackness on the non tension side of the cable.

Operation of the valve motor is regulated by a controller located in a waterproof enclosure on the top of the valve assembly. The controller receives power and a control signal from the aircraft via a three conductor cable. The control signal is provided in the aircraft via a momentary push button and relay.

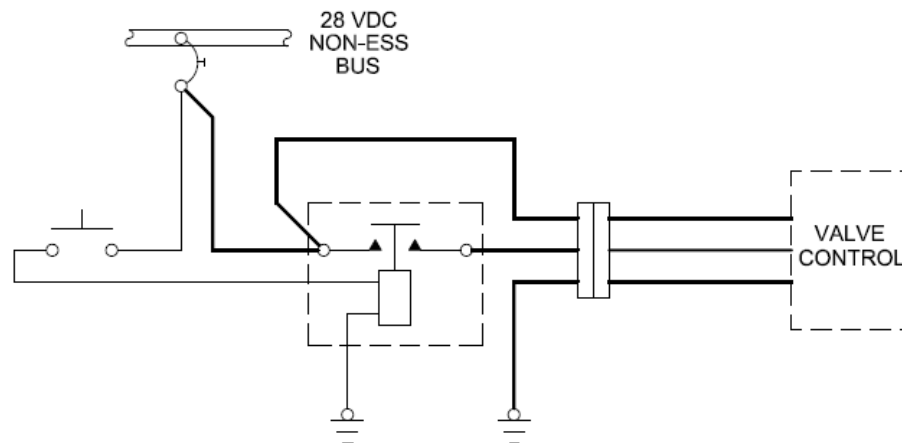

Caution

The control enclosure is hermetically sealed. Unauthorized opening will void the warranty.

Valve position feedback to the controller is provided by a sensor cam and two sensors. The sensor cam is located on the front of the cable drum and rotates with the motor and cable drum. The sensors are located in the controller enclosure. As the sensor cam rotates, a cut-out in its face actuates the sensors, signalling to the valve controller if the valve is closed, open, or somewhere in between. The sensors are a proximity type and are not affected by any non-metallic contamination of the water.

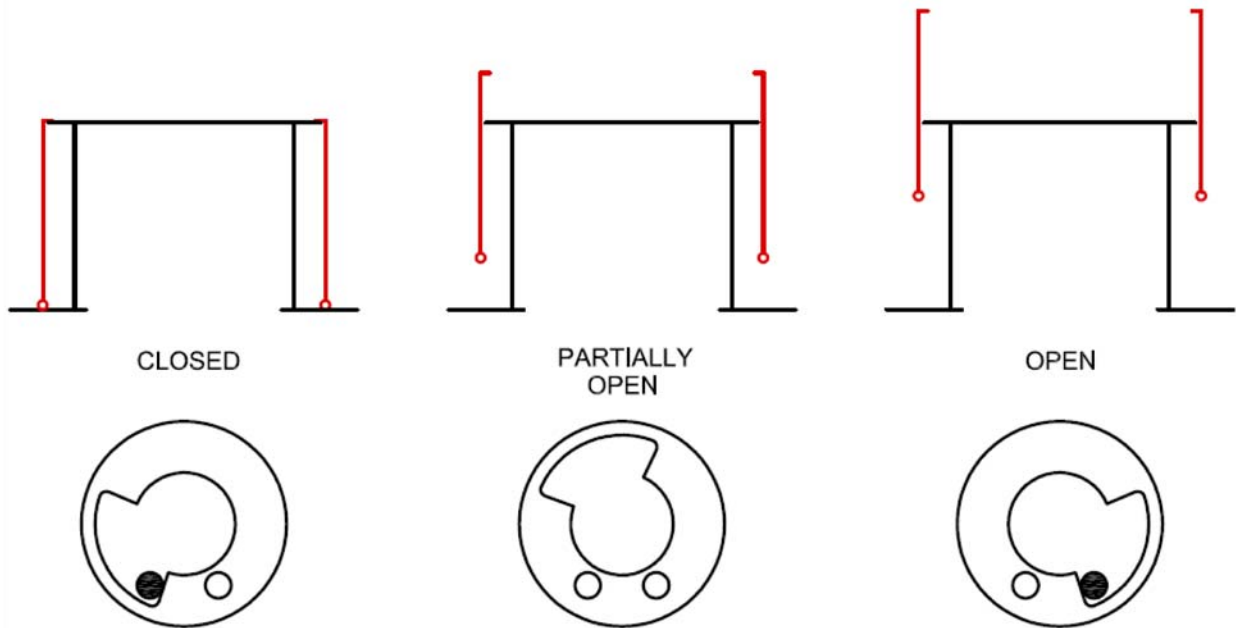

When the controller receives the open signal from the aircraft, the valve motor rotates clockwise and opens the valve. When the open sensor is triggered by the cam, the motor turns off and the valve remains in the open position as long as the open signal is present.

When the operator releases the push button, the open signal is removed. The motor rotates clockwise and closes the valve. When the closed sensor is triggered by the cam, the motor turns off and the tube remains in the closed position.

The sensor cam can rotated on the drum to adjust the valve position. Rotating the cam clockwise will lower the valve; counter-clockwise will raise the valve. See *Section 4: Making Adjustments*.

There is a status indicator lamp on the side of the control enclosure which indicates where the controller thinks the valve is.

Indicator	Status
White (Off)	No Power
Yellow	Valve Closed
Flashing Green	Valve Partially Open
Green	Valve Open
Red	Sensor Fault

The controller has an internal motor protection system to prevent the motor from being overloaded. When excessive current flows to the motor due to a stalled condition, the motor protection device activates.

When activated, the device isolates the motor from the power source, but does not remove power from the rest of the controller. The controller and valve will remain locked in whatever state they were at the time the motor protection device was activated.

To reset the motor protection, turn off power to the circuit using the aircraft's circuit breaker. Wait for approximately 10 seconds and turn the power back on again. The valve should return to its normally closed state.

Section 2: Deploying the Bambi MAX

Deployment Instructions

Attaching to the Cargo Hook

Caution

The Bambi MAX may not be suitable for a direct hook-up to the cargo hook. The actual hook-up will be different for various aircraft and operators must comply with all instructions and bulletins supplied by the aircraft manufacturer. It is the operator's responsibility to ensure that the Bambi MAX is correctly fitted to the helicopter.

The Bambi MAX is rigged for a longitudinal cargo hook. Correct attachment is indicated when the ballast on the Bambi faces forward in flight.

Caution

It is important that the ballast faces forward in flight. This will avoid twisting of the suspension lines.

Head and suspension lines.



For this style of head, if using a swivel hook, we recommend that you always operate in the locked position to assure that the ballast is always facing forward in flight.

Important Note

If you are using a swivel with an electrical connection, then it is acceptable for the Bambi MAX to be flown without the ballast facing forward. The Bambi MAX has been tested with some aerospace swivel arms and performs very well despite rotating in flight. The swivel also prevents the suspension lines from twisting up after dipping the Bambi MAX.

In some cases, where the cargo hook is too large for the standard shackle, a ring larger than the shackle can be used.

Warning

When a ring is used to turn the bucket 90 degrees, choose a ring that is the same size as the shackle on the head.



Ring not supplied. Please use a load rated link.

Connecting Power

The power requirement to control the Bambi MAX valve is 5 amps, 24/28 VDC. The Bambi MAX comes with a three-conductor, 16-gauge control cable that comes from the valve to 3' above the head. Attached to the end of the cable is a male waterproof Nema 5-15 electrical plug (the female receptacle for the helicopter is attached). If an additional new plug is required, an IP67 or better must be used.

The purpose of this type of plug is to offer a clean breakaway if the Bambi MAX has to be jettisoned from the aircraft in an emergency. It is suggested that the plug be lightly taped together with vinyl tape, while in use, to ensure that wind action does not separate the plug during flight.

There are three types of suggested wiring installations (see *Appendix* for diagrams).

1. **Pilot control:** In this configuration, the control is wired into the pilot's control column through a relay.
2. **Pilot control (US interagency):** In this configuration, the control is wired into the pilot's control column through a 50 amp relay as per US interagency regulations. This system can also be used to control a heli-torch, etc.
3. **Crew control (remote power supply):** This configuration allows a crew member or a pilot to control the dumping of the bucket using a battery pack to supply the power to the remote switch. This also eliminates the high cost of pre-wiring the aircraft.

Bambi Max Model	Valve	PowerFill
	Current Draw Amps at 24.5 Volts	Current Draw Amps at 24.5 Volts
BBX1518	5	N/A
BBX1821	5	N/A
BBX2024	5	45
BBX2024S	5	45
BBX2226	5	45
BBX2732	5	45
BBX2732S	5	45
BBX3542	5	45

Using Longlines**Important Note**

It is recommended that operators, who choose to use the Bambi MAX with a longline, ensure that the longline is at least 50' long.

Longlines should be at least 50 ft. long to keep the Bambi MAX well clear of the helicopter's tail rotor. When using a longline, care must be taken in selecting the correct gauge of control cable. See the chart below for recommendations.

When purchasing a synthetic rope longline, we recommend that the customer also purchase a protective cover and have the conduit inserted at the time of manufacture. However, if this is not feasible due to different conduits for different applications, we recommend taping the conduit using duct tape (grey) at 3-4 ft. intervals along the longline and cover.

We do not recommend using zip ties to attach wiring/conduit as this tends to damage the cover and longline. When attaching conduit, allowances must be made for any stretch in the load bearing line and this must be taken into account when attaching to ensure that the terminations are not released from the belly, bucket or hook, etc.

It is also imperative to take extreme care when removing the conduit from the longline, especially if a knife is used to remove the tape as one could inadvertently cut through the cover and the damage the synthetic rope. It is important to remember that when conduit is duct taped to the outside of a longline, the flight characteristics can change. In our experience, it may take some time and a few trial flights to determine the length between attachment points of the conduit to the longline.

Longline Wire Details

Length		Valve		PowerFill	
Feet	Meters	Wire	Recommended Plugs	Wire	Recommended Plugs
0 – 75	0 – 23	16/3 SOW	NEMA 5-15P/NEMA 5-15R	#6 TEW	APP 6326G6
76 – 100	23 – 30	16/3 SOW	NEMA 5-15P/NEMA 5-15R	#6 TEW	APP 6326G6
101 – 150	30 – 45	14/3 SOW	NEMA 5-15P/NEMA 5-15R	#4 WELDING	APP 6326G6
151 - 200	46 - 61	12/3 SOW	NEMA 5-15P/NEMA 5-15R	#4 WELDING	APP 6326G6

Checking Suspension Cable Length**Warning**

Using a Bambi MAX with a greater overall length than the distance from the cargo hook to the front tip of the tail rotor on your helicopter could result in a tail rotor strike and possible loss of control of the helicopter which could result in injury or death.

Overall lengths of the Bambi MAX with standard rigging are provided in this manual. Before using the Bambi MAX, check for the maximum total length. To determine this length, measure the distance from the cargo hook to the front tip of the tail rotor on the helicopter you will be using and subtract 6” (152 mm).

Bambi MAX Length Chart

Bambi Max Model	Overall Length	
	Feet	Meters
BBX1518	13' 3"	4.04
BBX1518S	11' 9"	3.58
BBX1821	13' 6"	4.11
BBX1821S	11' 11"	3.63
BBX2024	17' 8"	5.38
BBX2024S	13' 5"	4.09
BBX2226	13' 6"	4.11
BBX2732	20' 7"	6.27
BBX2732S	12' 9"	3.89
BBX3542	21' 3"	6.48

Lengths are accurate to within 1%. Specifications subject to change.

To determine overall bucket length:

1. Stretch out the bucket on the ground, keeping the suspension lines taut.

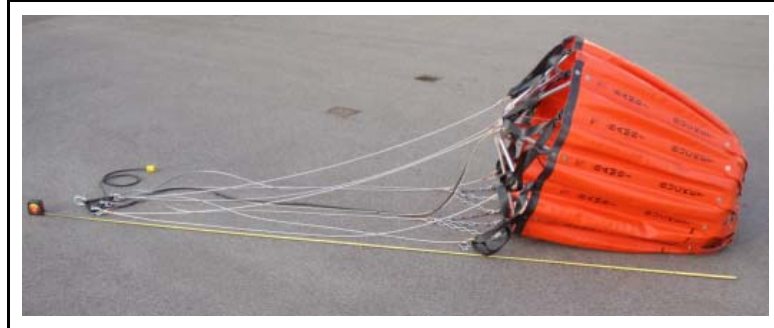

2. Measure the distance from the shackle on the head to the bottom of the shell. This measurement should be less than the maximum total length of the dimension taken from the helicopter.

Important Note

To avoid potential rotor strikes when using the Bambi MAX, the operator must measure the extended length of the Bambi MAX and the distance from the belly hook to the closest possible point of the tail rotor.

- A) Always measure the overall extended length of your Bambi MAX *and*
- B) Measure the distance from the belly hook to the closest possible point on the tail rotor.

"B" must always exceed "A" by at least six (6) inches.

Instant Deployment System (IDS)

The instant deployment system uses a hub and spoke mechanism to automatically expand the mouth of the bucket as soon as the weight of the Bambi MAX is taken up by the suspension cables. When the bucket is full, the IDS deployment cable and hub restrainer cables should be slack as they should not bear any load. Their function is to position the hub and spoke mechanism to hold the bucket open.

The main parts of the IDS are illustrated in this manual for maintenance purposes. To deploy the IDS on the ground, reach into the bucket, grasp the hub of the IDS and pull outward fully until the two restraining cables from the hub to the lower bucket shell are tight.

The IDS restraining cables are set at the factory and normally should not require any adjustment.

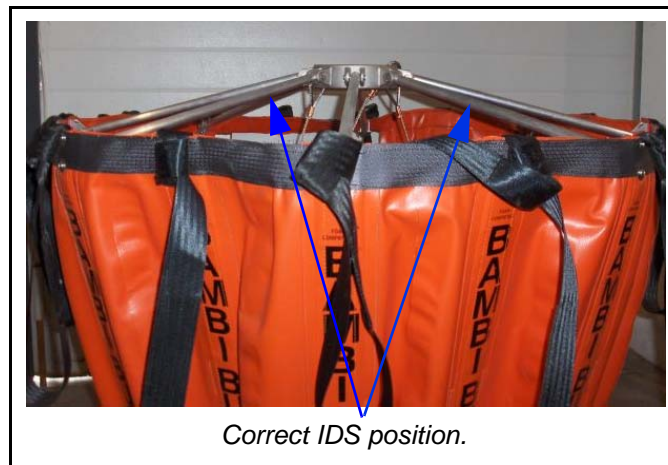

Section 3: Using Accessories

Using the PowerFill System

Important Note

PowerFill Snorkel is only available on 2024-3542 models.

System Overview

The PowerFill Snorkel system is comprised of one electrically-driven high-efficiency pump mounted onto a flange that is installed into the side of the bucket. The pump can fill the bucket rapidly and completely in water sources as shallow as 15” deep.

The PowerFill Snorkel pump system allows operators to get quick, partial or complete fills from a range of previously inaccessible shallow water sources including streams, canals, ponds and low profile dip tanks. Once the flange has been installed, the pump unit can be quickly attached and removed, as the situation requires.

The system can also be transported separately from the bucket, if required. The Bambi MAX, equipped with the PowerFill Snorkel, has the same handling, ease of transport and collapsibility as other Bambi MAX buckets in this size range.



Bambi bucket with PowerFill installed.

System Description

The pump is 28 volt DC powered, compact, light weight and efficient. The pump requires up to 45 amps of current and can pump 425 US gallons of debris-free water per minute (26 litres per second). Power is supplied by 28 volt DC power from the aircraft non-essential or utility bus.

Power is transmitted through a waterproof and oil-resistant cable to the pump motor. At the top end of the cable, a quick disconnect plug will separate with minimal force in the event of a load jettison. See the specifications section of this manual for wire sizes, etc.

The pump motor, impeller and housings are contained within a circular steel filter basket. The filter basket serves to protect the components from impact damage while also acting as a debris screen. The pump can run “dry” without damage.

The pump is fully waterproof in operation to a depth of 10 ft. (3.0 m) and has a standard hydraulic grease nipple provision to extend the life of the motor output shaft seal.

The mating flange consists of two plates that clamp together over the bucket shell to form a hard point for quick mounting of the pump unit. The flange can be installed on a number of buckets to accept the same pump unit. Mounted to the inside of the flange, a one-way flapper valve prevents water from flowing back through the pump when the pump is not running. If the pump is not in use for a period of time, a blanking plate should be installed to replace the pump.

The PowerFill Snorkel system comes complete with wiring harness. An optional control box can also be ordered.

Important Note

If you are switching pumps from one size of bucket to another, it is recommended that the discharge hose and restrainer chain also be changed to the lengths required for that bucket size.

Flying with the PowerFill Snorkel System

No prior experience is required to quickly master using the PowerFill Snorkel since flying a Bambi MAX with the PowerFill Snorkel will not adversely affect the flight characteristics of the bucket. To assist operators with installation of the PowerFill Snorkel in an aircraft, this manual contains a suggested wiring diagram.

Filling the Bambi Bucket with the PowerFill Snorkel System

Initiating a fill with the PowerFill Snorkel is simple and can be quickly mastered. Operation of the pump is accomplished by simply pressing the fill button for as long as it takes to fill the bucket.

MODEL	Optimal Fill Time (Sec.)
BBX2024	30
BBX2226	33
BBX2732	41
BBX3542	53

There are a few key points to keep in mind:

- To initiate a fill, the pump impeller must be immersed. It may not be possible to fill from water sources less than 15" (40cm) deep
- Opening the valve while immersing the bucket allows the water to enter the bucket, keeping the bucket more stable and decreasing the filling time.
- Once a fill has been started, the bucket will need to be supported by maintaining some tension on the suspension lines, particularly when the bucket is nearly full. If the bucket is not supported, the flexible nature of the bucket shell may allow it to collapse to one side as the water load increases.
- Frothing of the water or slow fill rate indicates the pump is not submerged for enough to maintain prime.
- The further the bottom of the bucket can be lowered into the water source, the faster the bucket will fill.
- It is recommended that the pump not be run when a conventional dip fill is possible.
- Do not run the pump if it is submerged to a depth of 10 feet (3 m) or more.
- Do not submerge the bucket to a depth of more than 20 feet (6.1 m) when performing conventional dip fills (pump off) in deep water sources.
- The filter screen is designed to filter out objects large enough to damage the pump impeller and to prevent weeds and debris from clogging the pump intake. If operating the pump in extremely dirty or swampy water sources, more frequent inspections of the pump impeller and filter screen may be required to maintain optimal function.
- The pump can be run dry without damage. However, maximum life can be obtained from the pump motor if the run time is limited only to filling the bucket. Excessive run time will require more frequent lubrication of the pump output shaft. See this manual's section 6 on *Maintenance and Troubleshooting* for the shaft seal lubrication procedure.



Using Foam

The Bambi MAX is designed to be effective with foam. All materials used in the manufacture of the Bambi MAX are resistant to the chemical action of foam.

Caution

After using foam or retardants, cycle through several dumps with water only or hose down with fresh water. This will prolong the bucket life.

Sacksafoam Foam Injection System

The Sacksafoam is SEI Industries' advanced foam dispensing system for use with the Bambi MAX. This system, exclusive to the Bambi, allows foam to be dispensed into the bucket in route from the filling source to the fire site.

There are three models of Sacksafoam to fit this range of Bambi MAX's. The operation of the Sacksafoam is controlled by the pilot through a control unit, which is mounted in the cockpit. Sacksafoam I contains the foam reservoir directly installed inside the bucket.



Sacksafoam I



*Sacksafoam II
Model 8044*



*Sacksafoam II
Model 5598*

The Sacksafoam II is a self-contained unit that can be stowed onboard the helicopter. This system is completely housed in a foam-resistant case. With the Sacksafoam II, the pilot still controls the foam dispensing through the control unit.



Sacksafoam Plus

If additional foam storage is required, the Sacksafoam Plus can be purchased to add an additional 40 gallons of foam on board.

Compatible Bambi MAX/Sacksafoam Models

Model	For Bambi Bucket	Reservoir USG	Capacity Liters
Sacksafoam I			
004338	BBX1518-BBX1821	12	45
004339	BBX2024-BBX4453	30	114
Sacksafoam II			
004344	BBX1518-BBX4453	25	94
Sacksafoam Plus			
004350	Sacksafoam II & III	40	151

Section 4: Making Adjustments

Adjusting Components

Valve Adjustment

The valve tube has seals located on the top and bottom of the tube. The vertical position of the tube when in the closed position determines the amount of valve sealing. The valve is adjusted at the factory to its correct position and should not require field adjustment under normal conditions.

Following major valve maintenance such as seal replacement or drive cable replacement, the valve adjustment should be checked. If the valve is adjusted too high, it will leak. If the valve is adjusted too low, the motor protection circuit may be activated.

Determine the current state of valve adjustment as follows:

- Power up the bucket circuit to allow the valve to move to the closed position.
 - If the indicator lamp flashes green or the cable drum / sensor cam oscillates when the valve is closed, then the valve is adjusted too low.
- Actuate the bucket dump switch and hold to keep the valve in the open position.
 - If the indicator lamp flashes green or the cable drum / sensor cam oscillates when the valve is open, then the valve is adjusted too high.

The adjustment procedure is as follows:

- Power up the bucket circuit to allow the valve to close.
- Remove power from the bucket circuit.
- With the valve in the closed position, locate the set screw on the top of the sensor cam which locks the cam to the cable drum. It should be at approximately the 12 o'clock position.



- Notice particularly the location of the 9 o'clock hole with respect to the cable anchor block. It is helpful to draw a reference line on the sensor cam to a reference point on the anchor block.
- Loosen the set screw on the sensor cam using a 3/32 hex key.
- If the valve is too low, adjust the valve upwards by rotating the sensor cam counter-clockwise so that your reference line moves approximately 1/16." Tighten the set screw.
- If the valve is too high, adjust the valve downwards by rotating the sensor cam clockwise so that your reference line moves approximately 1/16" (1 mm). Tighten one set screw.
- After adjustment, power up the bucket circuit.
 - The valve should move to the closed position.
 - The indicator light should have a steady yellow color.
 - The cable drum / sensor cam should not oscillate.
- Actuate the bucket dump switch and hold
 - The valve should move to the open position.
 - The indicator light should have a steady green colour.
 - The cable drum / sensor cam should not oscillate.
- Release the dump switch to allow the valve to close.
- Re-adjust the valve as necessary until the correct open and close conditions are met.
- Check to see if set screw is tight.
- Note the position of the reference line or draw a new line at the correctly adjusted position.

Section 5: Packing and Storage

Packing and Storing

Packing the Bucket

1. Open the valve 1-2 inches.



Important Note

Always leave the valve open 1 to 2 inches as this prevents the bottom seal from collapsing during long periods of storage, leading to longer seal life.

2. Collapse the IDS by pushing the hub into the bucket.



3. Grab the control head and pull the suspension lines taut. Tape the lines together in two bunches.



4. Insert the operations manual into the storage bag.



5. Gather the suspension lines into a coil and stow inside the bucket.



6. Place the head on top of the collapsed bucket.

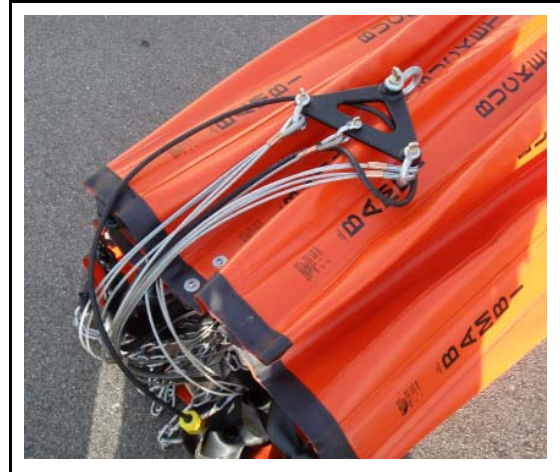

7. Roll the bucket into a bundle and wrap with straps supplied.



8. Rotate shell until head is under the shell.



9. Take the carrying bag and drape it over the bucket.



10. Roll the bucket over and insert the manual.



11. Close with zipper and store with label showing.



Storing the Bambi MAX

The Bambi MAX carrying bag makes a suitable shipping container when shipping via airfreight. Because of the compactness of the Bambi, many operators carry it aboard the helicopter, at all times, during the fire season. This allows for rapid deployment when required.

The following guidelines will help to ensure the longevity of your Bambi MAX:

1. Do not pile heavy objects on the Bambi MAX in storage. This may result in creases in the neoprene seal in the dump valve, which may cause leakage.
2. Wash the bucket and allow it to dry prior to storing it.
3. Do not store a wet bucket. This will result in the growth of mildew and the corrosion of aluminium and steel parts.
4. Store the bucket indoors in an unfolded position, preferably by suspending the main shackle from an overhead hook. An alternative is to suspend the bucket upside down from its bottom chain.
5. Before storing the bucket for an extended period, perform the seasonal maintenance procedures as outlined in *Section 6: Maintenance*.

Section 6: Troubleshooting and Maintenance

Troubleshooting

Valve Troubleshooting

Problem	Status Lamp	Possible Cause	Solution
No Power	Off (White)	Circuit breaker tripped	Reset circuit breaker.
		Aircraft / longline wiring	Check aircraft / longline wiring.
Circuit Breaker Trips	Off (White)	Aircraft / longline wiring	Check aircraft / longline wiring.
		Mechanical jamb	Clear jamb / check linkage
		Valve adjusted too high	Adjust valve down.
		Valve adjusted too low	Adjust valve up.
Valve Closed Won't Open	Flashing Green	Motor protector activated	Power cycle to reset. Adjust valve up.
	Yellow	No open signal	Check aircraft / longline wiring.
		Controller failure	Contact service center.
	Green	Damaged drive cable	Replace drive cable.
	Red	Controller / sensor failure	Contact service center.
Valve Open Won't Close	Flashing Green	Motor protector activated	Power cycle to reset. Adjust valve down.
	Green	Controller failure	Contact service center.
	Yellow	Damaged drive cable	Replace drive cable.
	Red	Controller / sensor failure	Contact service center.
Valve Leaks	Yellow	Damaged seals	Replace seals.
		Valve adjusted too high	Adjust valve down.

Checking Aircraft / Longline Wiring

- Set the multimeter to measure DC voltage.
- Install the black lead into the narrow socket of the helicopter wiring harness.
- Install the red lead into the round socket of the helicopter wiring harness.
 - The multimeter should read approx. +28V.
- Actuate the bucket dump switch.
 - The multimeter should still read +28V.



- Move the red lead to the wide socket of the helicopter wiring harness.
 - The multimeter should read 0V.
- Actuate the bucket dump switch.
 - The multimeter should now read +28V.

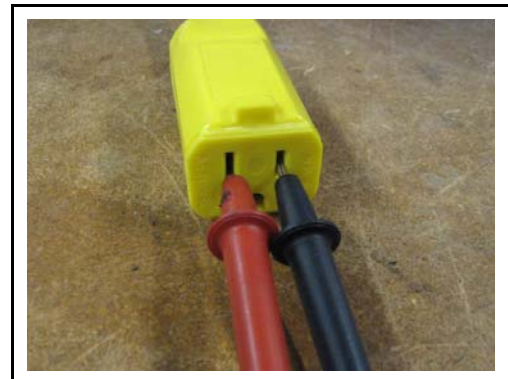

If a longline is being used, re-connect the longline into the aircraft wiring harness and repeat the above procedure for the receptacle on the bottom of the longline.

PowerFill Snorkel Troubleshooting

Problem	Possible Cause	Solution
Pump Won't Run	Circuit breaker tripped.	Reset circuit breaker.
	Disconnected cable.	Check cable connections.
	Incompatible power supply.	Compare power supply output with pump requirements.
Circuit Breaker Trips	Debris jamming pump.	Remove debris.
	Damaged motor.	Replace motor.
No Water Flow	Motor running backwards.	Check cable connections.
Pump Noisy	Pump impeller worn or damaged.	Repair / replace pump impeller.
	Debris in impeller housing.	Remove debris.
Fill Times Excessive	Debris filter clogged.	Clean debris filter.
	Pump impeller worn or damaged.	Repair / replace pump impeller.
	Excessive voltage drop in longline.	Use larger gauge cables.
	Damage to cables.	Repair / replace cables.

Maintenance Procedures

In addition to the daily pre-flight inspections as outlined in the operations manual, follow the weekly inspection procedure for times when the bucket is in continuous use.

Bambi Bucket Weekly Inspection Checklist

1. Check all parts of the system for visible damage or defects.
2. Check for excessive movement in linkage.
3. Check top and bottom valve seals.

Warning

Disconnect power to the pump motor before performing visual inspection of pump impeller.

PowerFill Weekly Inspection Checklist

1. Clean all debris from the pump motor impellers and debris screen.
2. Assess the function of the pump by running it.
3. Inspect pump impeller for signs of damage, particularly on the leading (lower) edge of the impeller blades.
4. Inspect the one-way flapper valves on the pump exit duct (inside the bucket) for cuts or tears.
5. Inspect the motor conductors for cuts or signs of chafing or wear. Immediately repair any damage to the conductor cable installation.
6. Ensure each cable connector is securely attached to its cable and free from cracks or damage.

Pump Output Shaft Lubrication

The pump output shaft must be lubricated periodically to preserve the life of the seals. Good seal condition will prolong the life of the motor by preventing moisture and other contaminants from entering the motor case. Lubrication will require a hand pump grease gun with a standard hydraulic coupler.

Caution

The lubrication of the pumps output shaft seals is critical to the longevity of the pump. Failure to follow the recommended lubrication intervals may result in premature pump failure. See this section's instructions on pump output shaft lubrication intervals.

Grease Procedure

Interval: All models, every 300 fill cycles.

Important Note

Regular air fills do not count as fill cycles if pumps are not operated.

1. Remove the three nuts securing the filter basket to the top mount ring and pull the filter basket free from the pump assembly.
2. Gently apply one to two pumps of grease to the grease nipple using enough to purge grease through the seal.
3. Check for dirt or gravel accumulation between the seal cup and the bottom shank of the impeller. Also, clean out any dirt and debris that may have accumulated inside the filter basket.
4. Re-install the filter basket.

Unscheduled Maintenance

Unscheduled PowerFill Maintenance Procedures

Please follow the procedures described in this section for maintenance on the PowerFill Snorkel pump unit.

1. **Removal and installation of the discharge hose:** The discharge hose has to be stretched slightly to fit over the discharge elbow and the pump housing. When removing or replacing the hose, undo the hose clamps completely and work the hose from side to side while restraining the pump unit and/or discharge elbow. When installing the hose, apply soapy water or a small amount of petroleum jelly to the inside lip of the hose to assist in getting the hose over the nipple. Use a round rod or screwdriver to help pry the hose onto the nipple – in a manner similar to changing a bicycle tire. If you have a new piece of hose, cut a 1/8" (3 mm) chamfer on the inside edge of the hose before installation.
2. **Two O-ring seals reside in the filter mount ring:** One seals the pump housing and one seals the interface between the filter basket. Whenever the filter basket is removed, always check the condition of the mating seal. If cut or broken, it should be replaced with a new seal. If disassembly of the pump proceeds to the point where the pump housing is separated from the filter mount ring, replace the mating seal.
3. **Conductor cable seal:** If removing the pump motor, impeller or impeller housing, you will need to break the silicone RTV seal at the conductor cable through the point on the filter mount ring. Upon reassembly, apply a small amount of silicone RTV sealant to re-seal the cable.

Important Note

A good seal at the filter mount ring will prevent pump cavitation in water less than 16" deep.

Section 7: Valve Maintenance

MAX Valve Repair and Replacement

Linkage Adjustment

If excessive side movement develops in the linkage, the bolts (with arrows) must be tightened. Do not overtighten these bolts as they must be turned with only a small amount of force. Once tightened, try to move the linkage from side to side. There should be no movement.

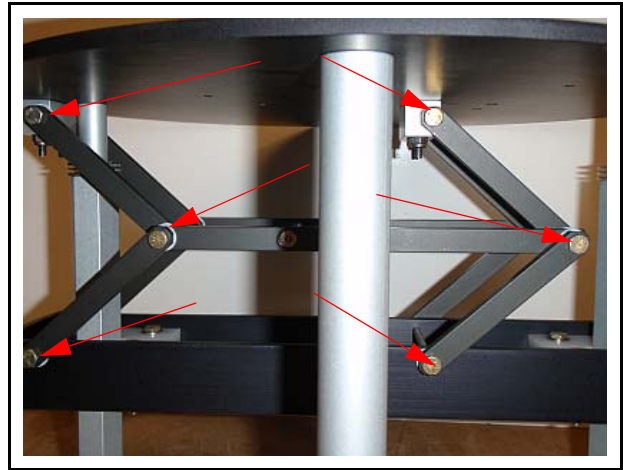

Valve Removal

Whenever any valve maintenance, such as seal changes or maintenance on the valve cycling, has to be done, we recommend that you remove the valve from the Bambi Max shell. To remove the valve, follow the steps listed below. Tools required: ratchet and 9/16" socket, side cutter.

1. Make sure that the ballast is on the bottom of the shell before removing the valve. Detach the power cable from the head and IDS deployment cable, coil the cable into an 18" coil and place it inside the top of the shell.



2. Next, detach one or two spokes from the shell; these spokes should be in the 3 to 5 o'clock location.



3. Now, remove the four bolts holding the valve to the bottom plate.

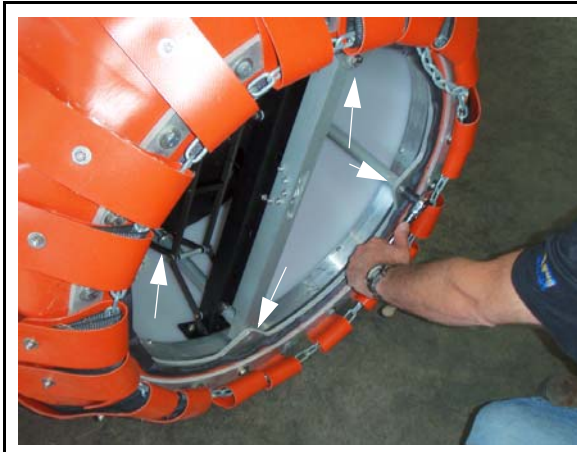

Note location of arrows for bolts.

4. Roll valve out of shell and move to repair area.



Installing the Valve

The following steps will allow one person to easily install the valve.

1. Making sure the ballast is still at the bottom, roll the valve through the opening. Leaving the control cable at the top of the shell, roll the valve to the base of the shell



2. Place the valve inside the valve-guard, then rotate the valve until the control box is in the position shown in the picture below.



3. Now, go around to the base of the bucket and insert the four 3/8" bolts. Some rotation may be necessary to line up the standoffs to the bottom plate holes. When lining up the holes, always move the standoff to the nearest bottom plate hole.

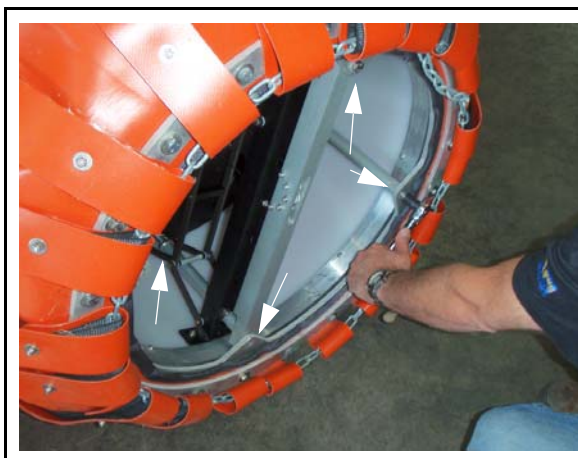

Note location of arrows for bolts.

- Next, string the control line. Before unrolling the coil of cable, pass it through the center of the IDS hub.



- Check to ensure that you have at least 6" of slack in the control cable before attaching the cable to the head with the four tie wraps.



Bambi MAX Seal Replacement

If either seal has to be changed, we recommend that the valve be pulled from the shell although it is not necessary to detach the control cable from the IDS deployment line when changing the bottom seal. Depending on circumstances, the valve seals can be replaced while the valve is next to the shell but the valve should be placed on a clean level surface such as a piece of cardboard or plywood.

To remove the valve, please refer to the valve removal section in the maintenance section of this manual. Once the valve has been removed, follow the directions below.

Bottom Seal Replacement

Tools required: Ratchet 1/4", drive extension short socket 5/16" or slot screwdriver.

1. To make the valve more stable, open the valve until the top of the tube is level with the top of the motor and cut the power to keep it in this location. If you have several Bambi MAX buckets, a Power Pack is available from SEI. This Power Pack can also be used as the main power source for operation of the bucket which eliminates wiring the helicopter for the Bambi MAX.



Valve in partially open position and shown with the Bambi Power Pack.

2. Turn valve over, as shown in this picture.



- Loosen the two hose tensioners and lower the clamp into the position shown in this picture.



- Remove the seal and clean any debris from the bottom of the tube and groove.

- Install the replacement seal and move the clamp into position. Make sure that two of the tensioner clamps are located between the lift bar bolts.

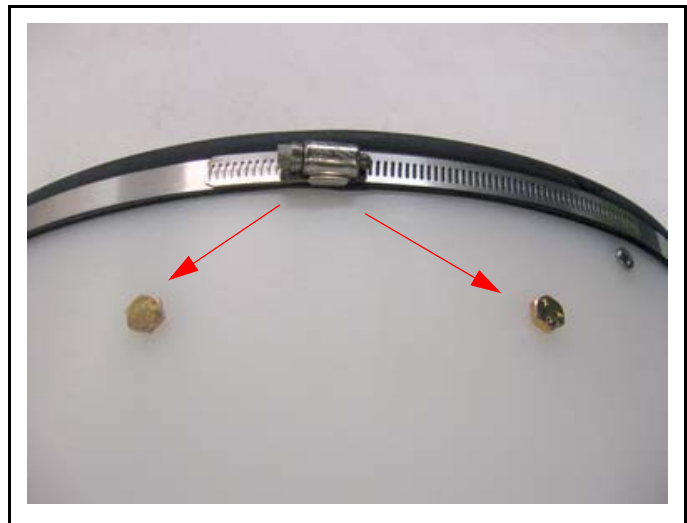

- Tighten the tensioner clamps. Make sure to tighten each clamp equally as this will eliminate a problem of the clamp releasing as one of the tensioners is not engaged enough to hold the clamp.

Top Seal Replacement

Replacement of the top seal doesn't necessarily require removal of the valve unless you are planning other maintenance functions at the same time. To remove the valve, please refer to the valve removal section in the maintenance section of this manual.

Tools required: Allen key 1/8"

1. To replace the top seal with the valve still in the bucket, first detach the control cable from the head and the IDS deployment cable and hub. Coil the cable up and place it inside the top of the shell.



2. Remove all the Allen head bolts from the top clamping ring. These bolts are extra long to give us maximum holding strength in plastic.



3. Remove the top ring and pass the coiled control cable through the middle of the ring.
4. Take the ring and old seal out of the shell. Place the ring on a level surface with all bolts inserted into the ring.



5. Slip the new seal over the bolts and return the ring with seal to the shell. Pass the control cable through the ring, making sure to pass the cable through from the seal side.



6. Now, start all bolts into the tube, turning them in about 1/8". This allows you to locate the holes in the tube easier by lifting the ring and seal to see the holes.



7. Tighten all bolts equally as they are going into plastic. Do not over tighten as you would in metal.

8. String the control line and, before unrolling the coil of cable, pass it through the center of the IDS hub. Once all the cable is outside the bucket with no slack, push it 6" back into the bucket.



9. Reattach the control cable to the head as shown in the picture using four tie wraps.



Drive Cable Replacement

Tools required: Cable cutter or sharp side cutter, Allen key 7/64", wrench 5/16", heat shrink tubing 1/8", heat gun.

If the helicopter is not available as a power and activator source, a 24-28 DC power source can be used. Connect the negative line to the narrow blade on the plug and the positive to the round pin. The valve will be in the closed position. To open the valve, jumper a wire from the round plug to the wide blade. If the valve doesn't operate, check that the wiring in the plug hasn't been changed. Open the plug and check the green wire which should go to the green screw, black wire to brass screw and white wire to silver screw.

Removing the Existing Cable

The drive cable can be replaced with the valve in the bucket but, if you are doing other maintenance work on the valve, it will be easier to change the cable outside the bucket.

1. Cut the cable below the lift bar.
2. Remove the cable retainer from the lift bar.
3. Remove the cable by pulling the unwaged end through the sheave and lift bar.
4. To remove the cable ends from the cable anchors, the motor will have to be started and stopped when a cable anchor is close to the top. Now, loosen the two cable anchor screws and pull the cable through. Then, activate the motor again to get the second cable anchor to the top, loosen the two cable anchor screws and pull the cable out.

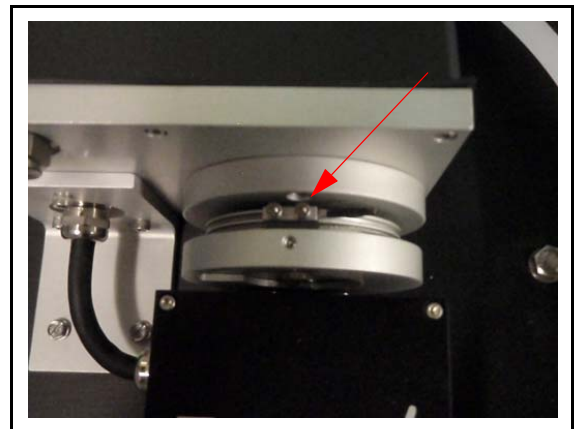
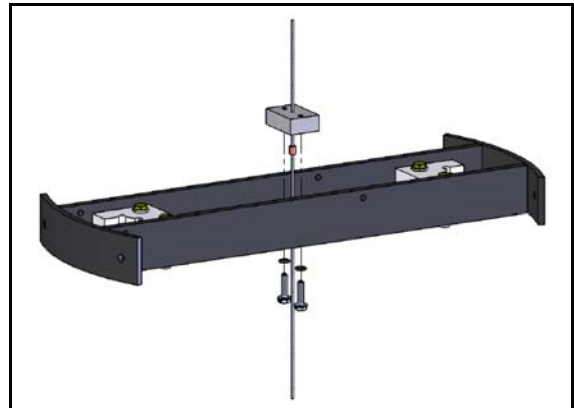

Important Note

Use cyanoacrylate glue (crazy glue) on the ends of the cable, if available, to prevent fraying.

Installing the New Cable

1. Examine the new drive cable to determine the shorter end.
2. Insert the short end of the drive cable into the cable retainer, then insert the long end of the cable through the hole in the lift bar.

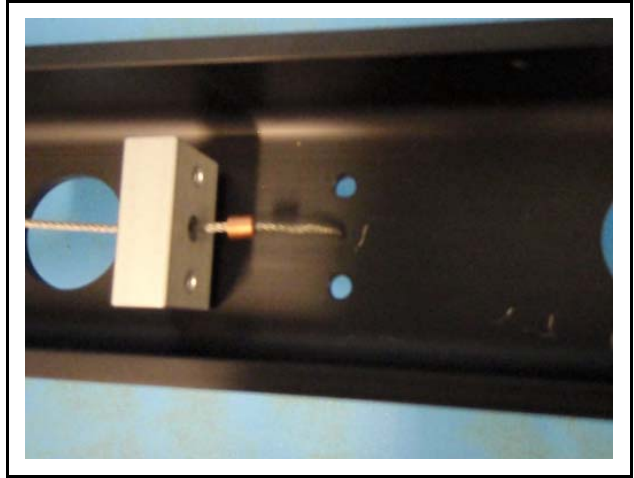

3. Secure the cable retainer to the lift bar.

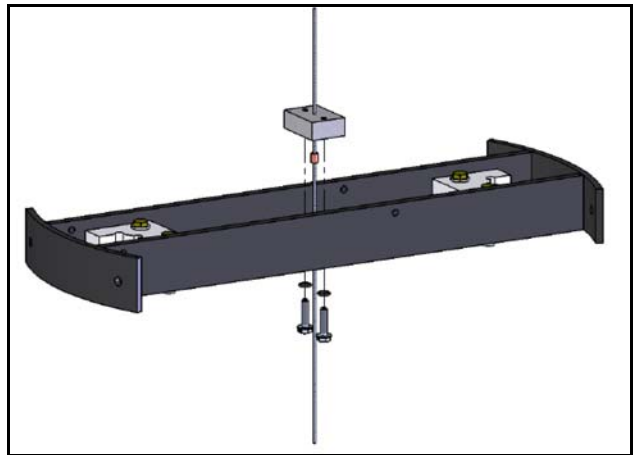

4. Trim the short end of the drive cable and insert the cable through the cable bushing.

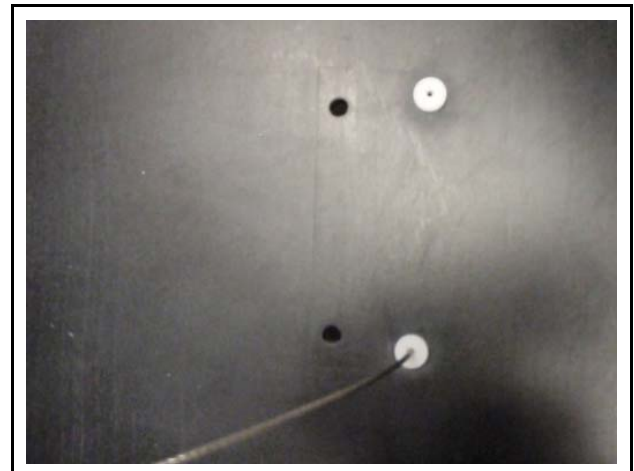

5. Connect the power control cable to a 24-28 volt DC power source, open the valve about a 1/3 of the way and cut the power. The cable anchor should be close to the position shown in this picture. Now, feed the cable through the cable anchor, pull it snug but do not tighten.

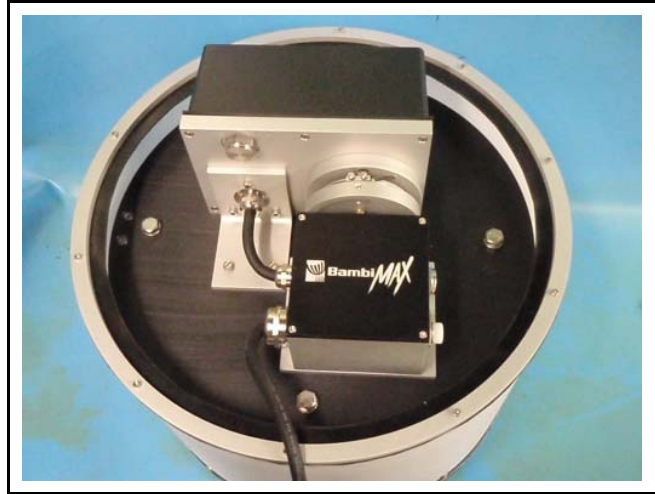

6. Install a 3/8" spacer plate between the sheave bar and lift bar. Place a heavy weight on the lift bar to hold it down.

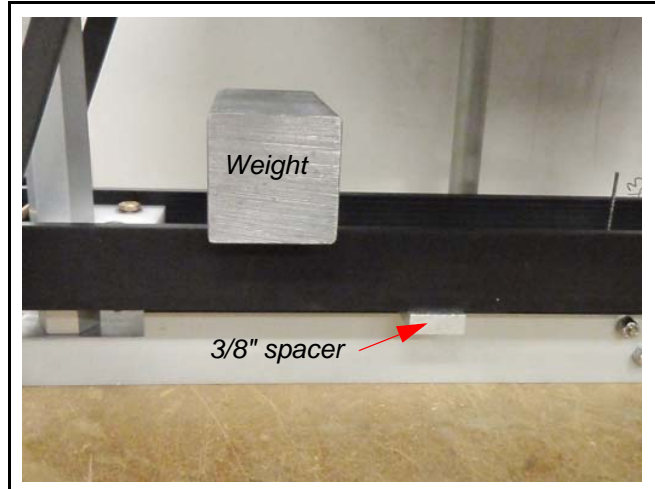

7. Turn on the power. The valve will close. Pull the cable tight and secure with cable anchor screws.

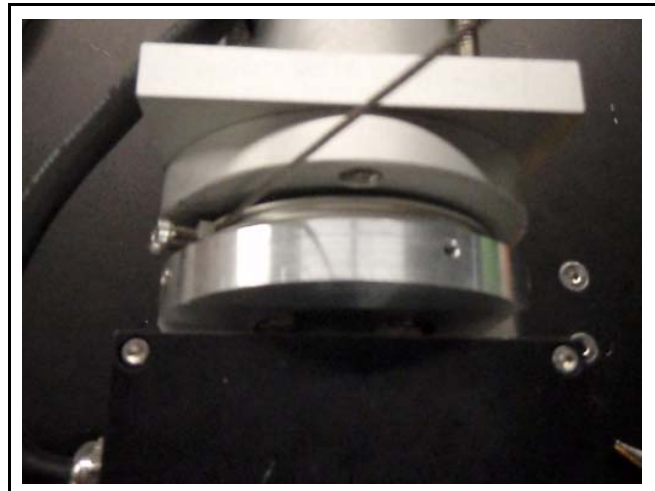

8. Install a piece of 1/8" x 1" heat shrink over the cable next to the anchor. Cut off the excess cable as close to cable anchor as possible.

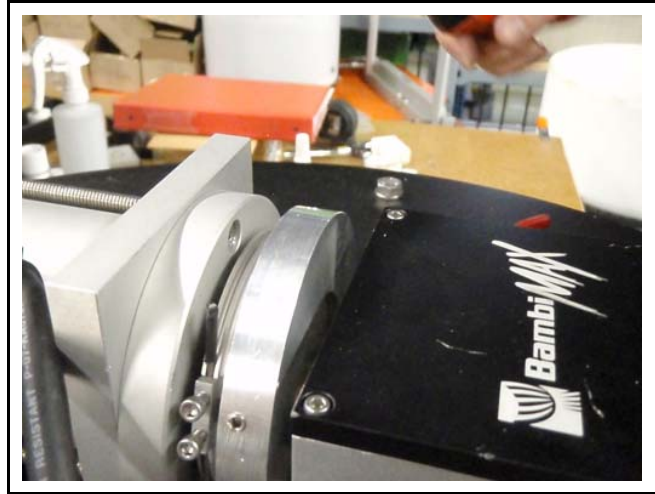

9. Remove the weight and spacer from the lift bar, install the cable over the five sheaves and trim the end of the cable. Now, pass the cable to the inside of the carrier cross bolt, through the cable bushing in the top plate.

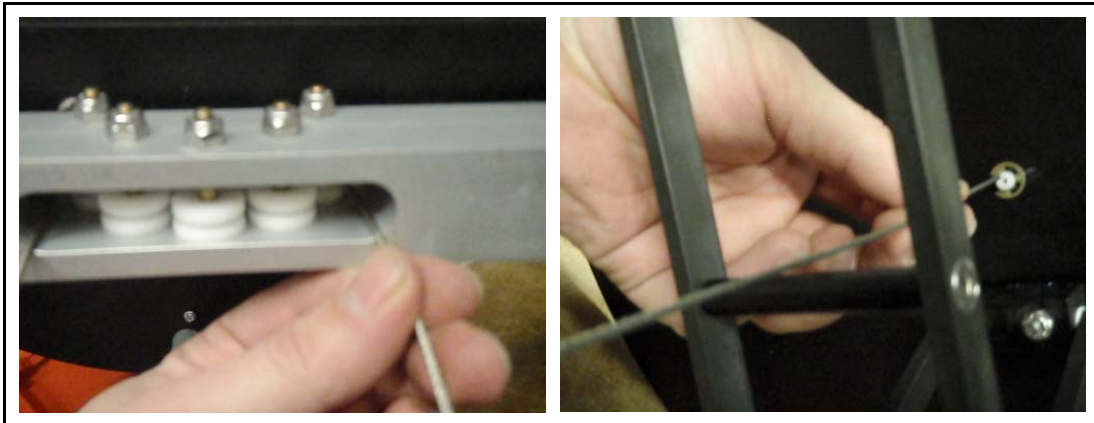

10. Turn on the power and open the valve to its full open position. Install the cable through the second cable anchor and, then, pull the cable tight and secure with cable anchor screws. Install a piece of 1/8" x 1" heat shrink over the cable next to the anchor. Cut off the excess cable as close to cable anchor as possible.

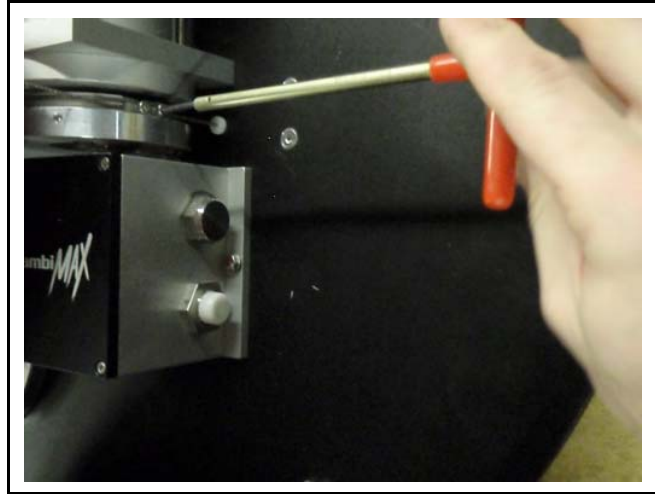

11. Adjust valve to correct position (see *Section 4* for more information).

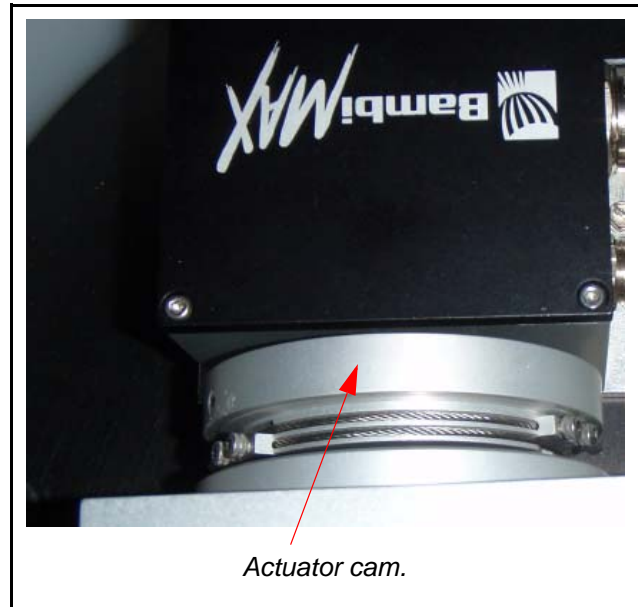

Changing the Guide Bushings

To change the guide bushings, follow the steps listed below.

1. Open the valve about half way.
2. Remove the two bolts holding the old bushings in place and remove the old bushings.
3. Place the new bushing into position.
4. Insert the bolts, attach the nuts and tighten.
5. Run the valve up and down. If any slowing of the valve movement or jamming is noticed, loosen the bolts on one bushing and pull the valve body away from the center of the valve and re-tighten the bolts.
6. If slowing or jamming still occurs, loosen the guide bushing bolts on the opposite side and repeat the operations of step 5.
7. The valve should be opened and closed several times. If it operates as it should, the bushings are changed correctly.

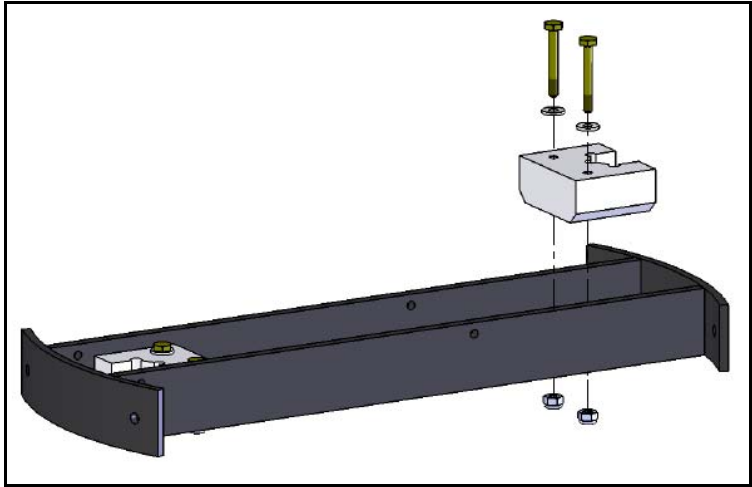

Section 8: Repair Quick Guide

Overview of Repair Categories

This section is intended to provide the user with information that will allow for the quick repair assessment evaluation of the Bambi Bucket. The repair assessment process is almost identical for all sizes of the Bambi Buckets, with some exceptions for minor bucket design variations between the models. This section also offers specific guidelines that sort the component defects into one of four categories: Safety, Operational, Monitor and OKAY. Use the guideline definitions to determine how urgently a repair should be carried out.

Category 1: Safety

All defects in this category must be repaired immediately before further operation of the Bambi Bucket occurs. Ignoring defects in this category could result in personal injury or damage to equipment. These defects can compromise the following functions of the Bambi Bucket: structural integrity, flight stability, water release and flight safety.

Category 2: Operational

All defects in this category should be repaired before the next operational day or approximately eight hours of flight time. The defects do not compromise the safety of the bucket but may lead to Category 1 defects, if not addressed within a short time frame.

Category 3: Monitor

Many defects such as wear, abrasion and minor impact damage do not need urgent attention. Defects of this nature should be monitored daily and repaired before they progress to a Category 2 defect.

Category 4: OKAY

The Bambi Bucket does not need repairs.

Important Note

Unfortunately, it is impossible to provide a recommended service time frame as some buckets are used often while others are used only rarely. In addition, buckets are shifted between operators, making it difficult to track usage. If you are unsure of your bucket's status, check with any Bambi Bucket Service Center, in your area, for more information and assistance.

Important Note

If more information is required, refer to the Bambi Bucket Operations manual, the Bambi Bucket Service manual (for the model being used) or the Bambi Bucket Repair Assessment manual.

Bucket Shell Repair Criteria

Category 1: Safety

Cease operations and repair immediately.

- One or more broken top loop knots (M-strap attachment point to the shell).
- Gross punctures through shell that cut or severely damage one or more panel strips.
- Separation of fabric welds longer than 3” (76 mm).
- Punctures or cuts through shell longer than 3” (76 mm).
- Two or more broken bottom webbing loops.

Category 2: Operational

Repair before next days operation or eight hours flight time.

- Top loop knots that are worn or have damage to more than 25% of the fabric.
- Cuts, punctures or weld separations less than 3” and/or cut through more than 25% of a panel strip.
- Bottom webbing loops with more than 25% damage to fabric strands.
- Broken or missing bottom webbing protective wear strips.
- Five or more broken battens.

Category 3: Monitor

Monitor and/or repair if condition deteriorates.

- Wear, abrasions, and cuts to the bucket shell fabric isolated to one side of the material that do not cut through.
- Wear, abrasions and cuts to the webbing loops, strips and top loop knots that involve less than 25% of the fabric strands on any portion of the affected webbing.
- Wear and abrasions to webbing protective strips.
- Up to 4” (102 mm) of peeled weld on panel strip.
- Up to four broken battens.

Category 4: Okay

Does not need repair.

Cables Repair Criteria

Category 1: Safety

Cease operations and repair immediately.

- One or more broken suspension cables or end fittings.
- Broken deployment cable.

Category 2: Operational

Repair before next days operation or eight hours flight time.

If three or more individual suspension cables or the deployment cable have the following defects:

- 10 or more randomly distributed broken strands or four adjacent broken strands
- Visible kink(s).
- Separation of the strands due to twisting (known as “bird-caging”).
- Evidence of heat damage.
- Abrasion wear comprising of more than 1/3 of the original diameter of the outside individual strands.
- Any visible reduction in outside diameter due to overload.
- Cracked or broken end fittings (some elongation of cable eyes is acceptable).

Category 3: Monitor

Monitor and/or repair if condition deteriorates.

- Wear, broken strands, kinks and twisting in cable that do not exceed the limits defined in Category 2 defects.

Category 4: Okay

Does not need repair.

IDS Hub Repair Criteria

Category 1: Safety

Cease operations and repair immediately.

- Cracks or breaks across the major section of the IDS hub.
- Two or more broken or cracked spoke brackets.
- Two or more broken or missing spokes, clevis pins, shell brackets.
- Three or more bent spokes (bends in excess of 20 degrees = broken).

Category 2: Operational

Repair before next days operation or eight hours flight time.

- One broken or cracked spoke bracket on IDS hub.
- One broken or missing spoke.
- One broken or missing clevis pin or shell bracket.
- Up to two bent spokes.

Category 3: Monitor

Monitor and/or repair if condition deteriorates.

- Wear on IDS hub.
- Dents, abrasions and wear on spokes.
- Clevis pin and shell bracket wear.

Category 4: Okay

Does not need repair.

M-Straps and Top Chains Repair Criteria

Category 1: Safety

Cease operations and repair immediately.

- Broken top chains.
- Broken or missing shackles.
- Two or more broken M-straps.

Category 2: Operational

Repair before next days operation or eight hours flight time.

- M-straps with more than 25% of the fabric strands broken.
- Visibly worn top chains.
- Bent, gouged, worn or cracked shackles and shackle pins.

Category 3: Monitor

Monitor and/or repair if condition deteriorates.

- Damage to an M-strap that does not exceed 25% of the fabric.
- Minor wear, impact marks or corrosion on chains.
- Minor wear, impact marks or corrosion on shackles.

Category 4: Okay

Does not need repair.

Control Head Repair Criteria

Category 1: Safety

Cease operations and repair immediately.

- Any visible crack or break on the head.
- Visibly bent shackles.
- Broken or missing safety wire on shackle pins.
- Broken or exposed electrical conductors.
- Broken or missing break-away plug.

Section 9: General Repairs

Repair Instructions

Suspension Line Replacement

A suspension line should be replaced whenever it displays noticeable kinking or fraying. Factory replacement lines come pre-swaged with connection links to make replacing quick and easy.

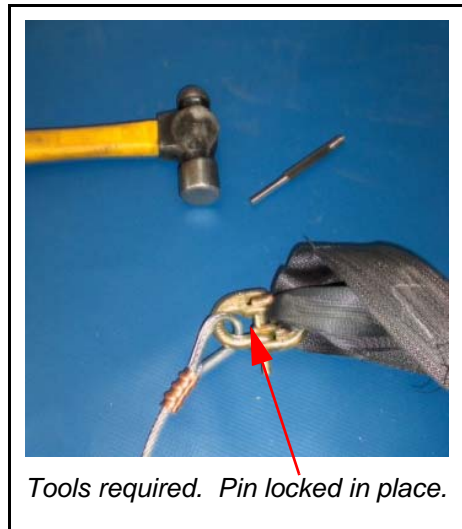

To remove the connecting link (connecting the suspension line to the M-strap), follow these procedures.

Locate a metal bar with a 5/16" hole (or drill a 5/16" hole into any metal bar). If you are unable to locate a metal bar, a wooden block will work, however, make sure to drill the hole into the end grain.

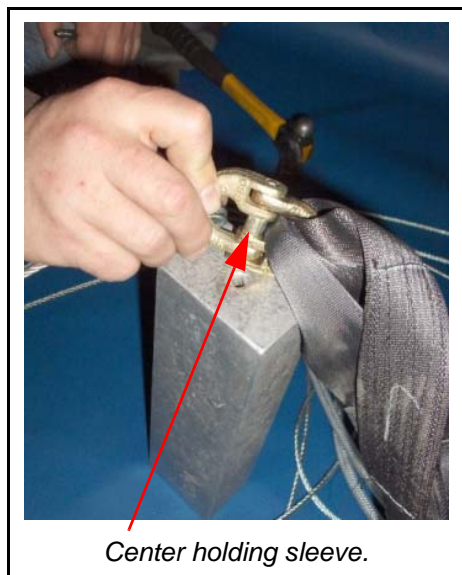

8. Place the connecting link with the pin located over the hole and using a 3/16" punch, drive pin through the center holding sleeve.
9. After the pin is free, remove the old suspension line. Place the new line in the connecting link by inserting the pin into one side of the connecting link. Using a hammer, drive the pin in until it is flush with both sides of the connecting link.

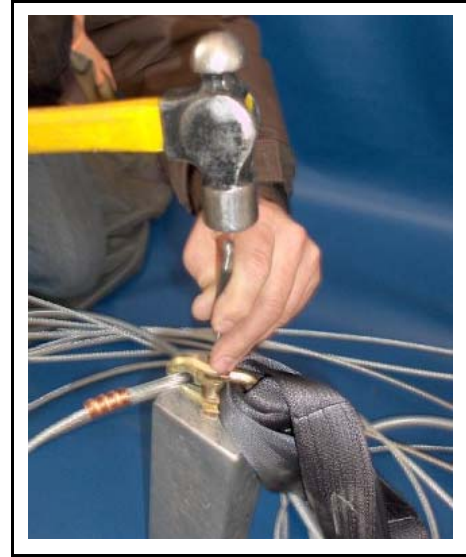

M-Strap Replacement

Replace M-straps if they become noticeably worn. M-straps may be repaired, if frayed, by melting the fray with a lighter to stop the fray from spreading. The length of the M-strap is critical to the proper functioning of the Bambi MAX and we recommend that you replace worn straps with factory-supplied equipment.

There are two types of straps; long webbing and short webbing. Long webbing are used for the diagonal straps while short webbing are used for the vertical straps.

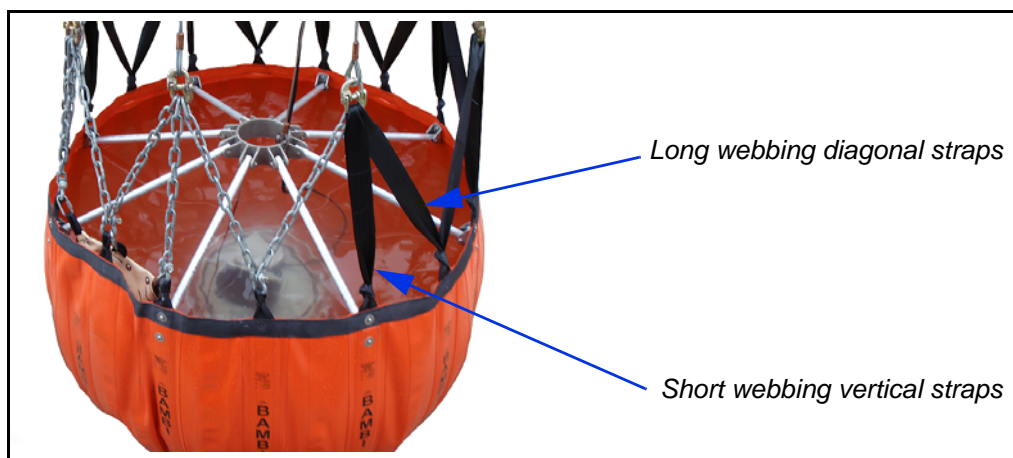

When replacing straps, do one set at a time to avoid confusion. Cut off the old straps from the shackle and un-tie them from the top of the bucket shell. Attach replacement straps as per the originals.

Removing Old M-Straps

1. Using needle nose pliers, insert the tip under the top webbing layer.



2. Fully insert the pliers at the far left hand side of the top layer.



3. Holding the pliers tight, turn your hand clockwise. Repeat the operation until the knot is loose enough to remove the strap.



Installing New M-Straps (Short)

Once the old straps have been removed, the new strap installation can begin.

1. Rotate the strap until the joint is centered.



2. Pass the strap through the loop.



3. Twist the loop eye 180 degrees.



4. Rotate the eye to the opposite side.



5. Pull strap end through the eye.



6. Pull strap tight.



Installing New M-Straps (Long)

Once the old straps have been removed, the new strap installation can begin.

1. Locate the center of the strap.



2. Pass the strap through the loop.



3. Twist the loop eye 180 degrees.



4. Rotate the eye to the opposite side.



5. Pull strap end through the eye.



6. Pull the strap tight.



7. The M strap set should now look like this. The suspension line attaches to the top of each M-strap set.



Bottom Loop Repairs

If the bottom loops, which hold the chain, become worn, the frays can be melted with a lighter to prevent them from spreading. If the bottom loops require replacement, they should receive an overlay of heavy duty wear-resistant webbing.

Bucket Patching

Please see *Bucket Repairs* in this section.

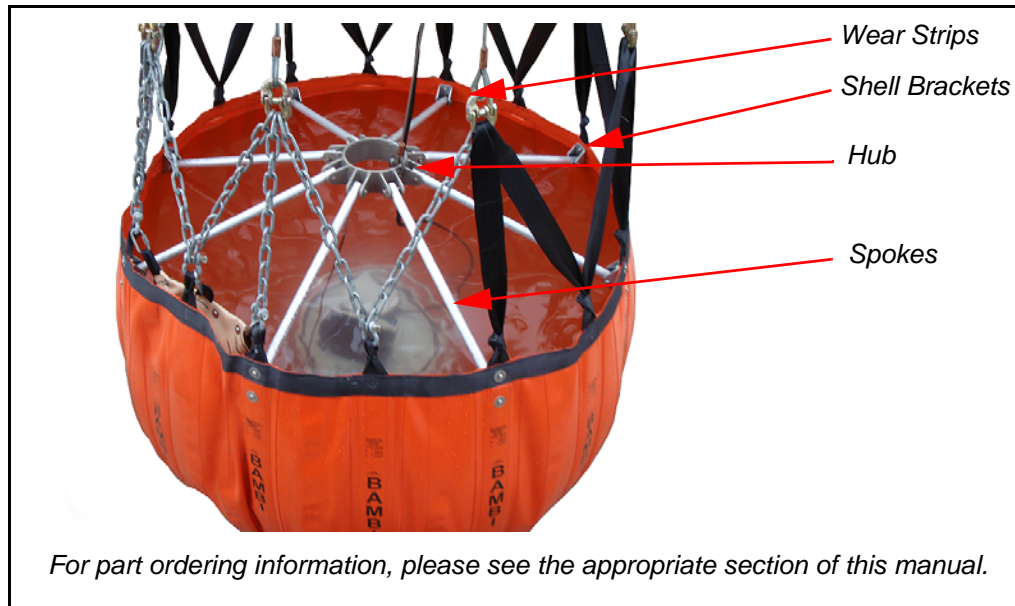
IDS Hub/Spokes Replacement

The IDS can be purchased either as a complete kit or as individual pieces, as required. Follow the procedure below to replace the entire assembly.

1. Start by removing the old IDS including the shell brackets and the old restrainer cable brackets. You will have to disconnect the tripline from the valve or control head since the tripline passes through the hub.
2. For re-assembly, first install the new shell brackets. This can be accomplished by installing the bolts through the bucket shell, fitting the fabric wear strips onto the bolts and, then, fitting the brackets to the bolts. Install and tighten the Nylock nuts.
3. Install the two restrainer cable brackets. One is found below the ballast and the other is directly opposite (6 o'clock position). No wear strips are required for the restrainer cable brackets.
4. With the ballast oriented at the 6 o'clock position, rotate the IDS assembly so that the deployment cable faces upward and it's at the 3 o'clock position.
5. Attach the two spokes at either side of the 12 o'clock position using the stainless steel clevis pins. Complete by fitting the fender washer and cotter pin. Working around the bucket perimeter, attach the rest of the spokes.
6. Once the IDS is fully installed, test for fit. You should be able to pull the hub past the midpoint position with a slight effort. If the IDS is either too loose or too tight, it will require adjustment.
7. Remember to re-attach the tripline to the dump valve, passing the line through the hub. Also, attach the IDS deployment cable to the control head small adjustment chain.
8. Attach the two restrainer cables.

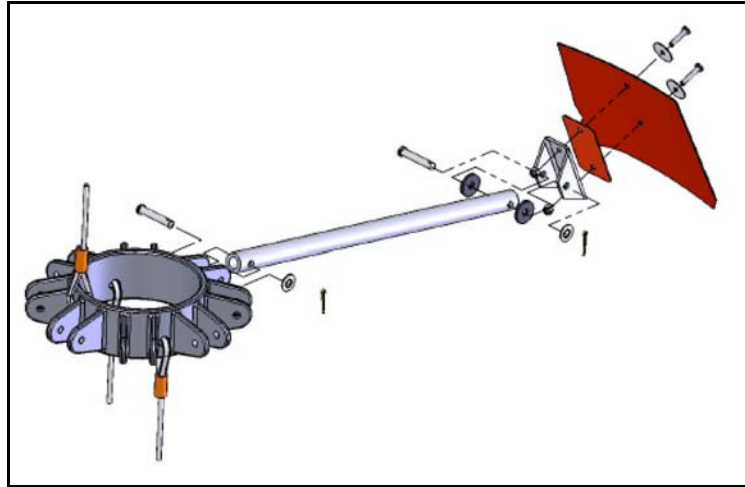

If the IDS is too tight, adjust two of the spokes as follows:

1. Cut off the spoke just above the existing hole on one end only. Then, redrill a new hole centred the same distance from the new end of the spoke as the other spokes. This will likely produce a good fit.
2. If the IDS is still too tight remove another spoke and repeat the above steps.
3. These two spokes are across from each other.

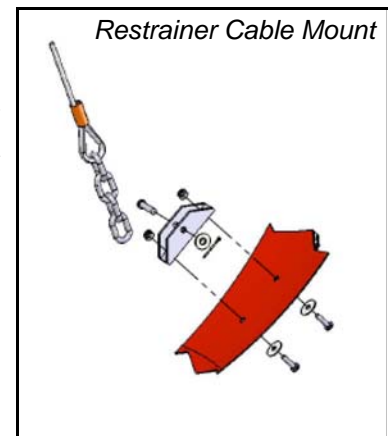

Bambi MAX Shell Repairs

Please read these instructions carefully and follow them exactly to obtain a good repair. Failure to follow these instructions or poor repair workmanship can lead to failed repairs and/or more damage to the bucket.

Before commencing repairs using glue, the weather should be warm (above 60 deg. F or 15 deg. C) and dry.

Important Note

Try a test repair before attempting to repair the bucket. This will verify your technique without risking damage to the bucket. It is much harder to fix a repair once a failed attempt has been made as the hardened glue is difficult to remove.

Repair Failures

Repairs will likely fail if:

- The area to be repaired is not perfectly clean and scrubbed to a matte finish before applying the patch.
- Repairs are attempted during wet or cold weather.
- The glue and patch are not properly placed, creating air bubbles between the glue and the patch.
- The patch is not weighed down for 24 hours.
- The bucket is used before the glue has set.

Important Note

Dura-Seal glue has been designed specifically for the SEI family of fabrics. The shelf life of this adhesive is about one year. Fresh adhesive can be obtained directly from SEI Industries Ltd.

Repairing in High Humidity

In conditions of high humidity, a proper technique is essential for securing the bond strength desired. The presence of surface moisture can destroy the effectiveness of the cemented bond.

The evaporation of solvent from the adhesive may reduce surface temperature below the dew point resulting in condensation of water vapour on the surface of the adhesive. This is often visible as fogging or a milky white appearance on the surface.

The use of a solvent to clean the surface prior to cementing can also reduce temperatures below the dew point.

To overcome the high humidity problem, raise the temperature of the patch area. This can be accomplished with a warm air fan.

Warning

- Glue vapours are highly explosive! Explosive vapours may occur causing fire and/or injury. Keep away from all sparks, flame, lighters or cigarettes.
- Solvent and glue are both extremely hazardous. Use solvent and glue under well ventilated conditions only.
- Use an approved respirator mask to avoid breathing fumes.
- When using a warm air fan, either use one which is rated EXPLOSION PROOF or make sure that there is a steady flow of air past the work area to remove fumes as they are generated.

Making Temporary Repairs with Sealing Clamps

Repair clamps are used for an immediate repair to prevent the loss of liquid through large rips or holes. For example, if a vehicle accidentally backed into a bucket and caused a 3" (76 mm) long rip in the bucket, a repair clamp could be inserted to stop the loss of liquid. Repair clamps are only used for temporary repairs. The damage should be permanently repaired with a patch when the bucket can be set aside for 24 hours.

Important Note

Leaving the clamp's string on makes it easier to remove the repair clamp when placing a permanent patch on the bucket.

1. Select the largest clamp that will just slip through the hole in the item. The size of cut or hole will determine the size of the sealing clamp to use.
 - For a cut or hole up to 2" (5 cm), use a 3" (7.6 cm) clamp (supplied).
 - For a cut or hole up to 4" (10 cm), use a 5" (12.7 cm) clamp (supplied).
 - For a cut or hole up to 6" (15 cm), use a 7.5" (19 cm) clamp (special order).

Caution

Use caution if deciding to enlarge the slit to insert a clamp. It is very easy to make the slit too large.

2. Keeping hold of the string, slip one half of the repair clamp through the hole as indicated.



3. Pull the bolt up through the hole. Turn it until the clamp lines up with the hole.

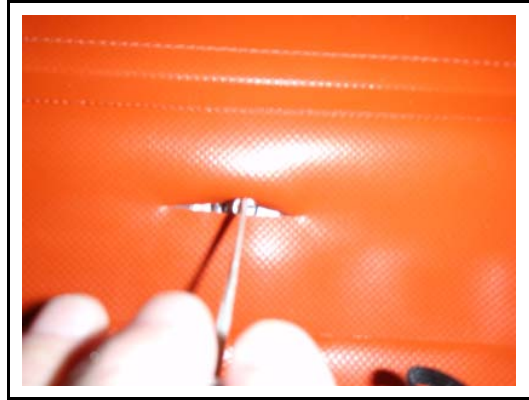

4. Place the top of the clamp over the bolt.



Caution

Tightening the nut with tools may break the bolt away from the lower clamp. Overtightening can also deform the clamp and cause leaks.

Temporary Repairs Using Glue

Important Note

Allow repair to harden for 24 hours at room temperature before using the item.

Applying the Glue

Small scrapes, damaged fabric coating or pinholes, which are not leaking, can be repaired with glue only. They do not require a patch. (A small scrape is defined as damage to the outer fabric coating only. A pinhole is defined as a small puncture that is not leaking.) However, damage to the base fabric must be repaired with a patch.

1. Fill the weight bag with water prior to beginning repairs.
2. Clean the area to be repaired with an abrasive pad dampened with solvent. Remove all traces of masking tape, if previously used. If possible, place a piece of masking tape on the back side of the item being repaired.
3. Paint the damaged area with glue. Use a thick coat of glue, overlapping the edges of the repair by 1" (25 mm). Be sure that the edges are well coated. A damaged coating should be given two coats of glue. Apply the second coat within four hours of the first coat.



Clean and apply masking tape on the backside of the tear.



Squeeze glue around the tear and spread with fingers.

Gluing with Patches

If there is dampness around the area to be patched, then dry the area with a hot air fan or heat gun. Any loose coating should be cut back with scissors.

1. Support the damaged area on a flat, solid platform. This platform should be strong enough to support the fabric (flat) and allow the patch to be rolled once it is in place.

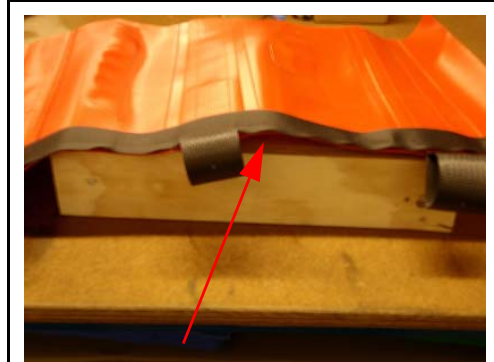

The damaged area should be supported on a flat, solid platform.

2. Scrub the damaged area with an abrasive pad dampened with solvent (isopropyl rubbing alcohol is recommended). Scrub vigorously to remove the cured surface. The area should be clean and dry with a dull matte finish.

**Caution**

Solvent will damage the fabric if too much is used or if the fabric is left exposed to solvent residue.

3. Wipe with a rag, dampened with solvent, to remove any residue from cleaning. Check to see if the area is totally clean and all coated surfaces and edges are dull. If not, repeat the cleaning. This is critical for a good glue bond.

Cutting the Patch

1. Cut a patch. The patch should be at least 2" (50 mm) larger in every direction from the damaged area. A round patch is recommended but, if a rectangular patch covers the damage better, then round all corners. Clean the patch by scrubbing with a pad dampened with solvent. Rub vigorously to remove the gloss from the fabric. Clean **both sides of the patch**, as it is easy to get the patch turned over during installation. Another reason the patch should be cleaned on both sides is that it will be painted with glue, on the outside, later.



The color of patch will vary, depending on the product repair kit.

Applying the Patch

1. Apply the Dura-Seal glue to the patch and damaged area. Wait 30 minutes (at 75F or 22C) for some of the solvent to evaporate from the glue. The glue should become thicker but still be quite wet. If it has been allowed to dry too long, give both sides another thin coat. If the glue has dried too long, it will be difficult to avoid entrapping air bubbles in the bonded joint.
2. Place the patch and roll it down with the roller. Place the centre of the patch down first, then roll it out towards the edges with the roller. This expels trapped air. Once the patch is rolled down, do not let it lift up. This will prevent air from getting under the patch which causes a weak bond.



3. Weigh down the patch. Place a plastic cover sheet over the patch followed by a weight bag for 12 hours at room temperature. Remove the weight bag and leave to dry for 24 hours.

4. If the patch will be subjected to abrasion after 24 hours, paint over the patch with glue. Painting the patch also provides protection from ultra violet light and weather. Allow the bond to harden for 24 hours at room temperature before using the item.



Hot Air Gun Patching

On most items, hot air gun patching is the preferred method because it provides the most durable, permanent repair possible.

Tools and materials required:

- Patches
- One plastic hand-held roller
- One hot air gun, Steinel HL 1800 E or equivalent:
120 V-1500 W (800 to 1100 deg. F, 450 litres per min.)
- One wide surface nozzle
- Isopropyl alcohol
- Scissors

Warning

It is extremely dangerous to use a hot air gun in the presence of flammable fumes such as gasoline or paint thinner. There is a high risk of explosion and/or burns.

Warning

Injury, especially to hands and fingers, can occur when using a hot air gun. Most welding will occur at temperatures of 800-1000 degrees F. Wear gloves to protect skin from overheating, burning and blistering.

Hot Air Gun Procedure

1. In a well-ventilated location, clean the area to be repaired as well as one side of the patch with an abrasive pad. Wipe down the repair area and patch with isopropyl alcohol.
2. Mount a wide surface air nozzle on the hot air gun so as to direct the heat flow in a large pattern. Turn the power on, adjust the temperature in the low range first and let the hot air gun warm up. Increase the temperature as required during the operation. **DO NOT OVERHEAT OR BLACKEN THE FABRIC.**

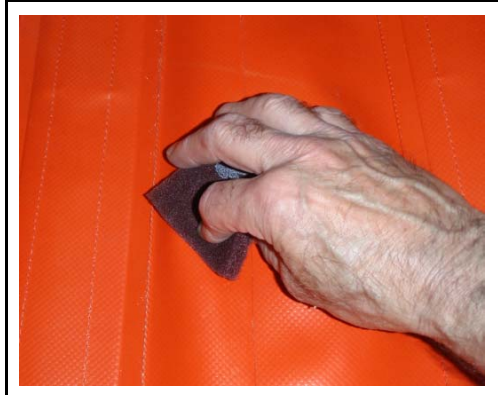
**Caution**

Overheating can occur quickly and can damage the product. It's recommended that you test, using the supplied fabric samples, to determine the correct temperature to be used and the duration of heat to be applied.

3. Starting from the centre of the patch (held down by the roller), concentrate the heat flow equally to patch and fabric. Apply a light pressure with the roller when the fabric starts melting. This can be seen as small bubbles. **DO NOT OVERHEAT.**
4. Roll the patch down to fuse it to the fabric, moving roller and gun simultaneously. Repeat on the unfused portion of the patch. Let the repaired area cool down. Attempt to peel off at the edges with your fingers. If there is even a slight peel, repeat the operation locally. Otherwise, the repair is finished.

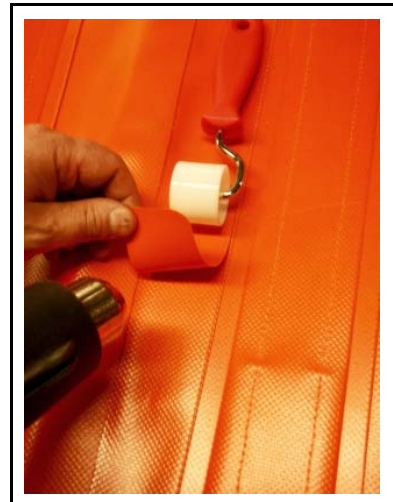

Repair Kits

Bambi Repair Kit 003613 (no glue)

Used for Bambi MAX's or other product lines where **no glue is required or allowed**.

Important Note

It is the responsibility of the dealer and end user to ensure that the importation of glue is allowed in the country of use.



Repair Kit Parts Table

PART NUMBER	DESCRIPTION	QTY.
011161	BAG, TOOL	1
003661	FABRIC REPAIR MANUAL	1
003608	BAG, WEIGHT	1
003064	PAD, ABRASIVE	2
003071	ROLLER, SEAM, 1 ¼	1
003074	SCISSORS	1
004502	CLAMP, REPAIR, SMALL, (2" HOLE)	1
003856	PATCH, FABRIC, 32OZ. BAMBI	3

Optional Supplies

PART NUMBER	DESCRIPTION	QTY.
003090	ADHESIVE, DURA-SEAL ¾ OZ.	1
003091	ADHESIVE, DURA-SEAL 8 OZ.	1
004503	CLAMP, REPAIR, MEDIUM, (4" HOLE)	1
004504	CLAMP, REPAIR, LARGE, (6" HOLE)	1

Section 10: Specifications and Parts

Capacity and Weight Specifications

Bambi MAX Capacity and Weight Chart

Bambi Max Model	Capacity			Gross Weight		Empty Weight	
	Imp Gal	US Gal	Liters	lb	kg	lb	kg
BBX1518	150	180	680	1590	720	93	42
BBX1518S	150	180	680	1590	720	92	42
BBX1821	180	216	820	1900	860	102	46
BBX1821S	180	216	820	1900	860	102	46
BBX2024	200	240	910	2140	970	137	62
BBX2024S	200	240	910	2140	970	135	61
BBX2226	220	260	1000	2330	1060	135	61
BBX2732	270	320	1200	2840	1290	145	66
BBX2732S	270	320	1200	2840	1290	140	63
BBX3542	350	420	1600	3650	1660	152	69

Bambi Max with PowerFill Snorkel Capacity and Weight Chart

*PowerFill Snorkel not available for 1518 and 1821 models.

Bambi Max Model	Capacity			Gross Weight		Empty Weight	
	Imp Gal	US Gal	Liters	lb	kg	lb	kg
BBX2024	200	240	910	2190	980	140	63
BBX2024S	200	240	910	2190	980	140	63
BBX2226	220	260	1000	2380	1070	140	64
BBX2732	270	320	1200	2890	1300	190	85
BBX2732S	270	320	1200	2800	1300	190	85
BBX3542	350	420	1600	3700	1700	200	90

Note: Capacities and weights are accurate to within 5%. Specifications subject to change. Check data plate found on inside of shell.

Caution

The selection of a Bambi MAX model for a specific aircraft is dependent on many factors including aircraft weight, fuel weight, operation elevation and atmospheric conditions. The helicopter operator must select a bucket model which is appropriate for their specific situation. The operator must also ensure that the bucket selected does not pose a tail rotor strike hazard.

Parts Listings

Bambi MAX Valve 16" Shell Assembly

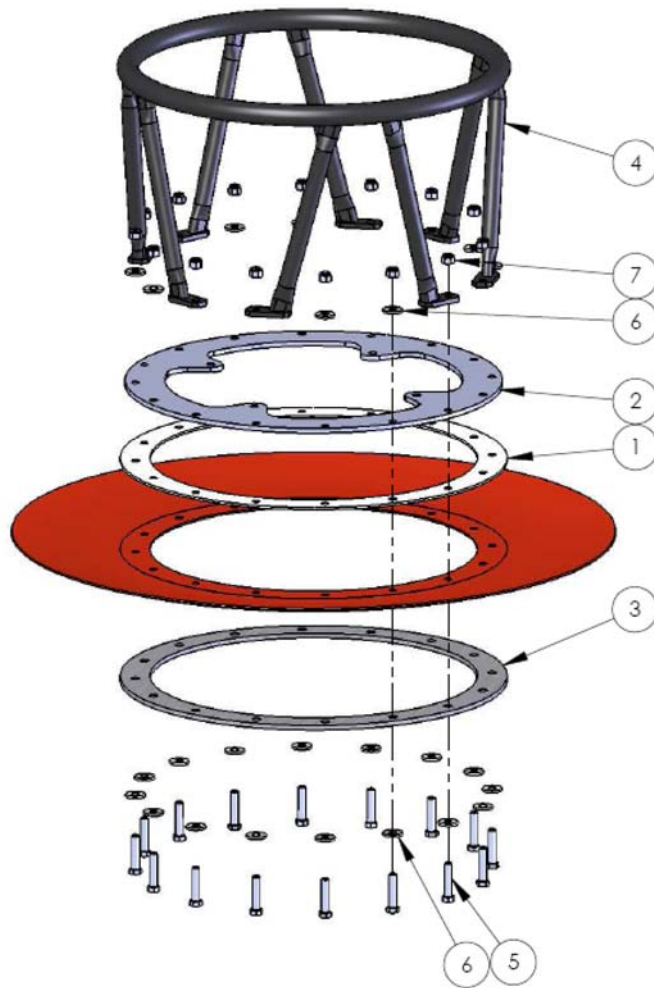

ITEM	MODEL	PART NUMBER	DESCRIPTION	QTY
1	BBX1518	004226	GASKET, SHELL, 16"	1
2		007138	RING, BASE, 16"	1
3		007141	RING, CLAMP, 16"	1
4	BBX3542	006881	GUARD, VALVE, 16"	1
5		000393	BOLT, HX, 3/8-16 x 1-3/4, SS	16
6		001846	WASHER, FLAT, 0.39 x 1.00 x 0.125, SS	24
7		001665	NUT, HX, NYLOCK, 3/8-16, SS	16

Bambi MAX Valve 16" Valve Installation

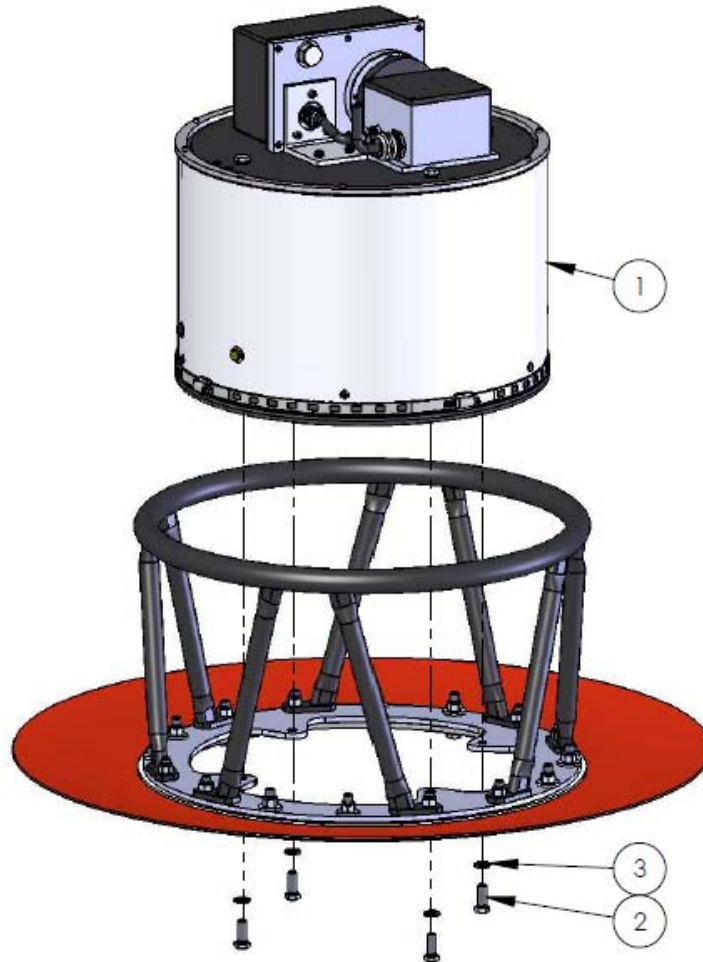

ITEM	MODEL	PART NUMBER	DESCRIPTION	QTY
1	BBX1518 – BBX3542	002298	VALVE, 16" ASSY, 1518MX-3542MX	1
2		012339	BOLT, HX 3/8-16 X 7/8, SS	4
3		001848	WASHER, LOCK, SPLIT, 3/8", SS	4

Bambi MAX Valve 16" Seals

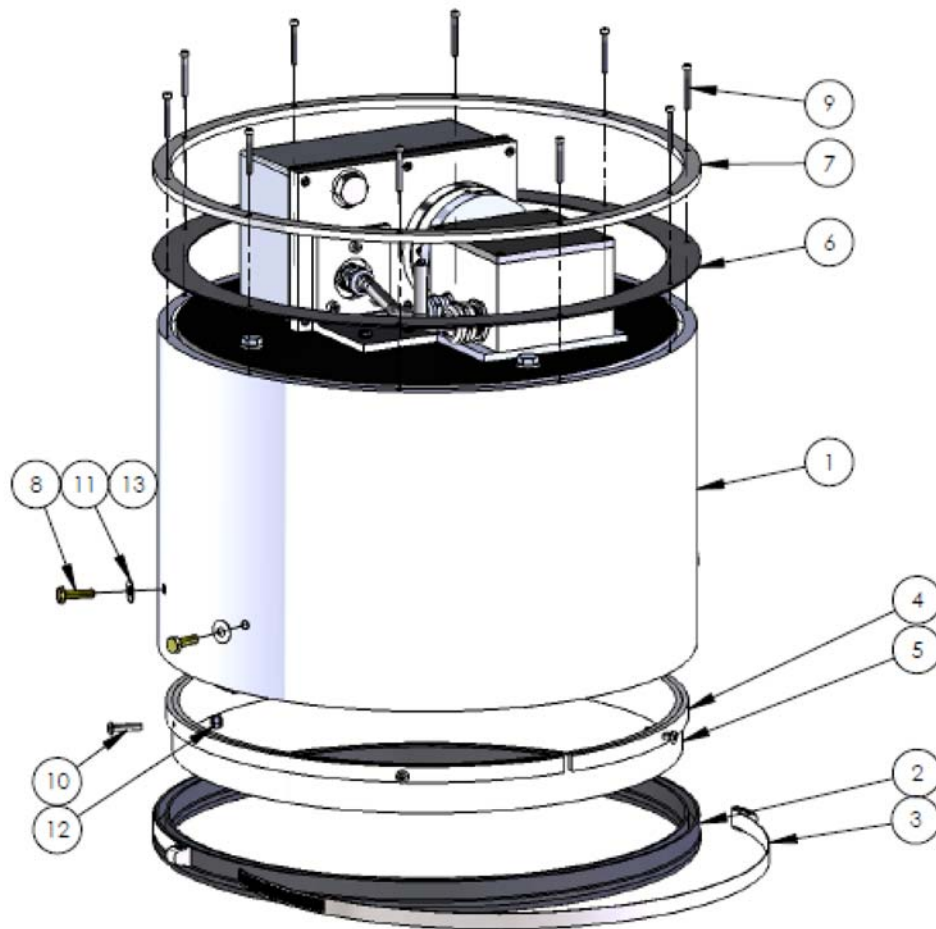

ITEM	MODEL	PART NUMBER	DESCRIPTION	QTY
1		007041	TUBE, VALVE, 16", MACHINED	1
2		006374	SEAL, VALVE, BOTTOM, 16"	1
3		011522	CLAMP, GEAR, 8" SS	2
4		010736	RING, SEAL, SPACER, 16"	1
5		005769	RING, SEAL, SUPPORT, 16"	1
6	BBX1518	006321	SEAL, VALVE, TOP, 16"	1
7	-	007335	RING, SEAL, TOP 16"	1
8	BBX3542	000009	BOLT, HX, 1/4-28 x 29/32, CAD	4
9		000416	SCREW, SC, 6-32 x 1-1/4" SS	10
10		000496	SCREW, PNP, 10-24 X 7/8, SS	6
11		001833	WASHER, FLAT, 0.28 x 0.69 x 0.036	4
12		001660	NUT, HX, NYLOCK, 10-24, SS	6
13		001688	NUT, HX, NYLOCK, 1/4-28, SS	4

Bambi MAX Valve 16" Actuator and Controller

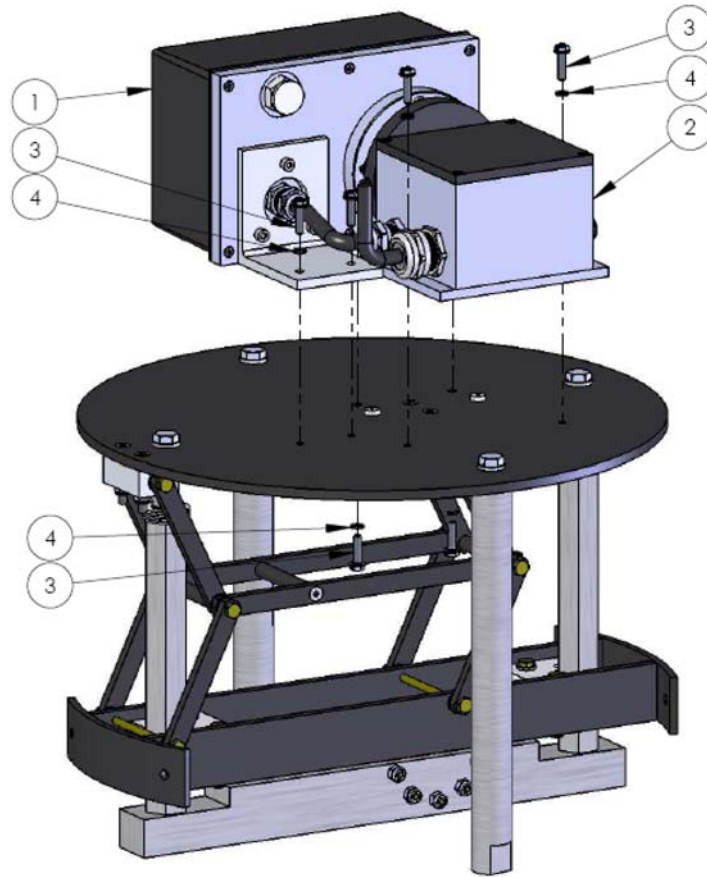

ITEM	MODEL	PART NUMBER	DESCRIPTION	QTY
1	BBX1518	000210	ACTUATOR, ASSEMBLY	1
2	-	000206	IVC, ASSEMBLY	1
3	BBX3542	001606	SCREW, 10-24 x 3/4", HXSL,SS	6
4		001848	WASHER, LOCK, SPLIT, #10, SS	6

Bambi MAX Valve 16" Actuator

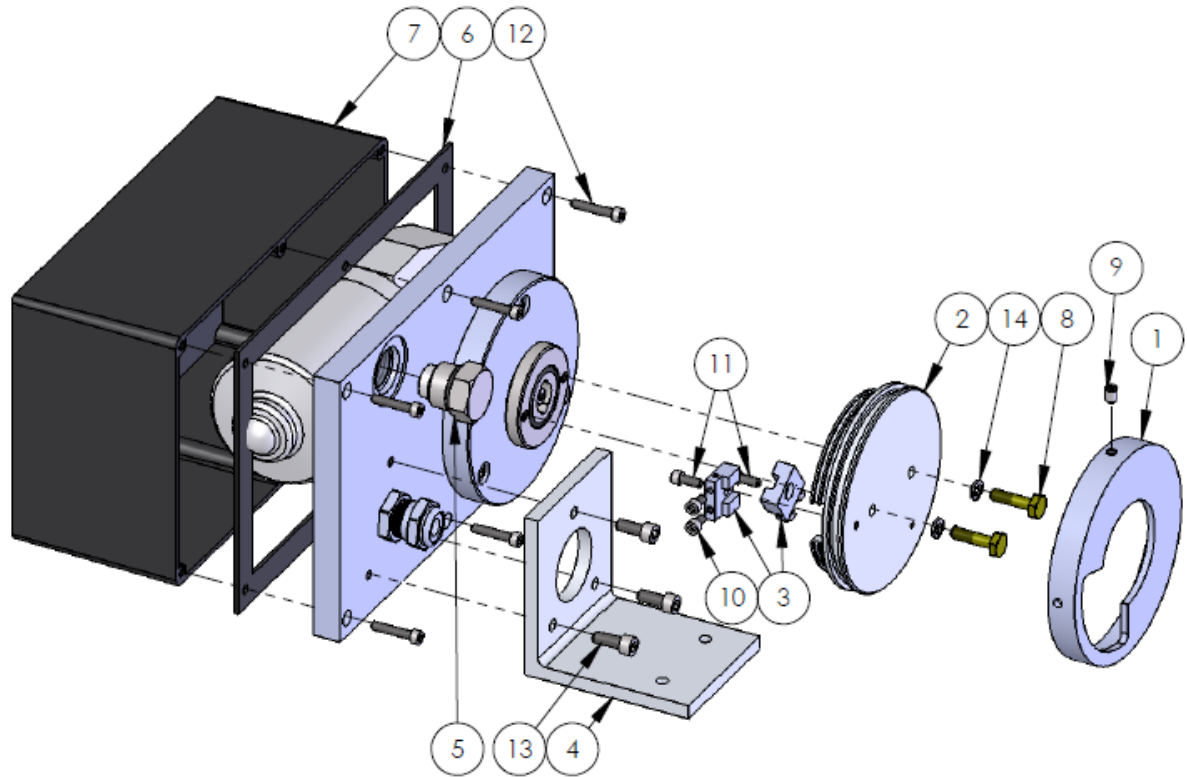

ITEM	MODEL	PART NUMBER	DESCRIPTION	QTY
1		000222	CAM, SENSOR	1
2		000220	DRUM, CABLE	1
3		000221	ANCHOR, CABLE	2
4		000214	BRACKET, MOTOR	1
5		000224	PLUG DESICCANT, ASSEMBLY	1
6	BBX1518	000225	GASKET, MOTOR	1
7	-	000267	ENCLOSURE, 7.4 x 4.3 x 3.1, AL	1
8	BBX3542	000280	BOLT, HX, 10-32 x 25/32, CAD	2
9		000525	SCREW, SET, CUP, 10-32 x 1/4", SS	2
10		000920	SCREW, SC, 6-32 X 1/4", SS304	4
11		000408	SCREW, SC, 6-32 x 3/8", SS	2
12		006660	SCREW, SC, 6-32 x 3/4", SS	6
13		000379	SCREW, SC, 10-24 x 1/2", SS	3
14		001848	WASHER, LOCK, SPLIT, #10, SS	2

Bambi MAX Valve 16" Actuator 2

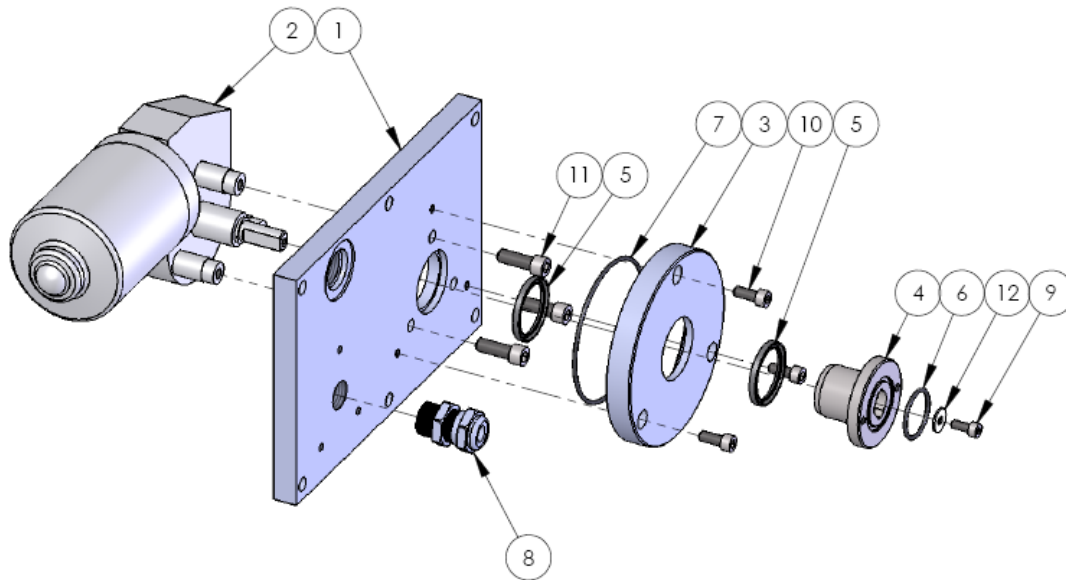

ITEM	MODEL	PART NUMBER	DESCRIPTION	QTY
1	BBX1518 - BBX3542	000215	PLATE, MOTOR, FRONT	1
2		007789	MOTOR, GEAR, 24VDC, 4.0A, 61RPM	1
3		000217	COVER, SEAL	1
4		000218	HUB, MOTOR	1
5		002928	SEAL, LIP	2
6		006335	O-RING, BUNA N, #020, 50A	1
7		005994	O-RING, BUNA N, #039, 65A	1
8		000500	GLAND, CABLE, NIBR, M16, IP68	1
9		000132	SCREW, SC, M4 x 0.7 x 10,SS	1
10		000379	SCREW, SC, 10-24 x 1/2", SS	3
11		001002	SCREW, SC, 1/4-20 x 3/4" SS, SEAL	3
12		001169	WASHER, FLAT, 0.17 x 0.472 x 0.039, SS	1

Bambi MAX Valve 16" Sheave Bar and Guide Rods

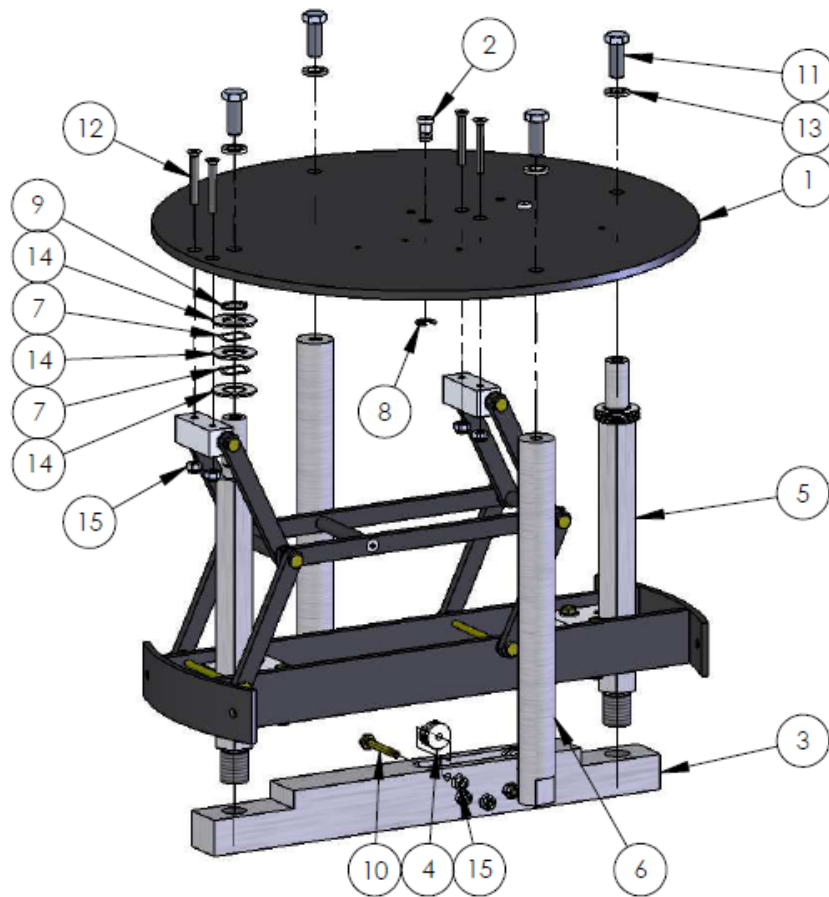

ITEM	MODEL	PART NUMBER	DESCRIPTION	QTY
1	BBX1518 - BBX3542	007135	PLATE, TOP 16"	1
2		001618	BUSHING, CABLE	2
3		000226	BAR, SHEAVE, 16"	1
4		001617	SHEAVE, CABLE	5
5		000231	ROD, GUIDE	2
6		000229	ROD, SUPPORT	2
7		007107	SPRING, DISC, 0.650 x 0.855 x 0.060, SS	4
8		005988	RING, RETAINER, EXT, 1/4" PLT	2
9		005214	RING, RETAINER, EXT, 5/8, SS	2
10		000012	BOLT, HX, 10-32 x 1-1732, CAD	5
11		012339	BOLT, HX, 3/8-16 x 7/8", SS	4
12		002241	SCREW, FSC, 10-32 x 1-1/2", SS	4
13		001853	WASHER, LOCK, SPLIT, 3/8, SS	4
14		006276	WASHER, FLAT, 0.64 x 1.19 x 0.060, SS	6
15		001685	NUT, HX, NYLOCK, 10-32, SS	9

Bambi MAX Valve 16" Lift Bar and Linkage

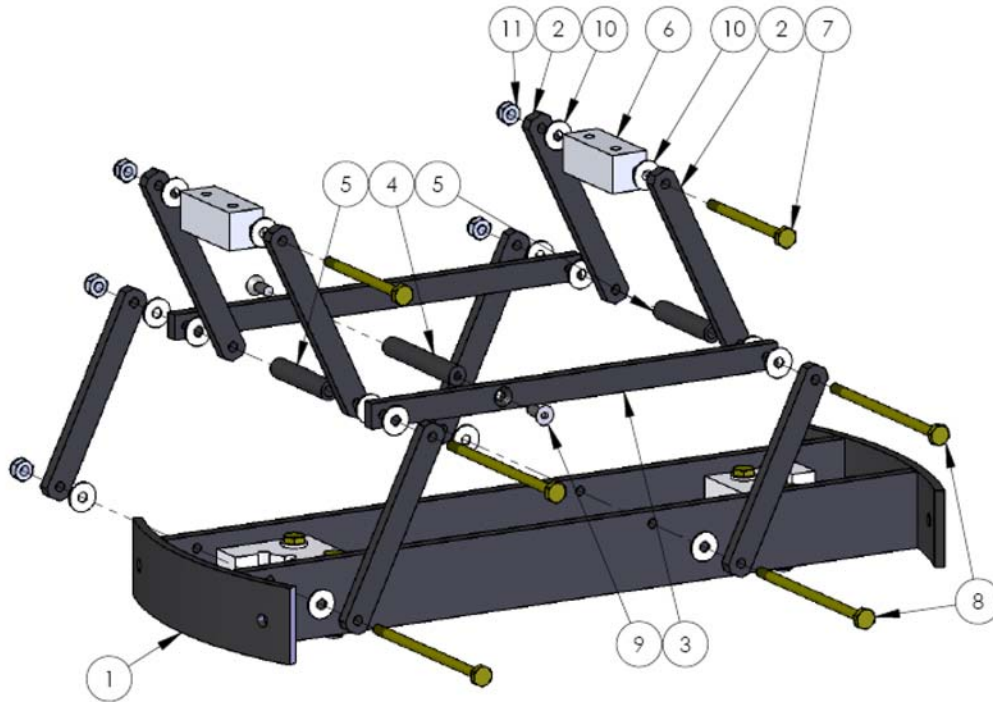

ITEM	MODEL	PART NUMBER	DESCRIPTION	QTY
1	BBX1518 - BBX3542	000233	BAR, LIFT, 16"	1
2		008660	ARM, LINKAGE, SHORT, 16"	8
3		008662	ARM, CARRIER, SHORT, 16"	2
4		008664	SPACER, SOLID, CARRIER	1
5		008874	SPACER, TUBE, CARRIER	2
6		008665	BLOCK, PIVOT	2
7		001755	BOLT, HX, 10-32 x 2-25/32, CAD	2
8		001771	BOLT, HX, 10-32 x 3-29/32, CAD	4
9		000449	SCREW, FSC, 10-24 x 1/2", SS	2
10		002269	WASHER, FLAT, 0.20 x 0.57 x 0.40, PTFE	16
11		001685	NUT, HX, 10-32, SS	6

Bambi MAX Valve 16" Lift Bar

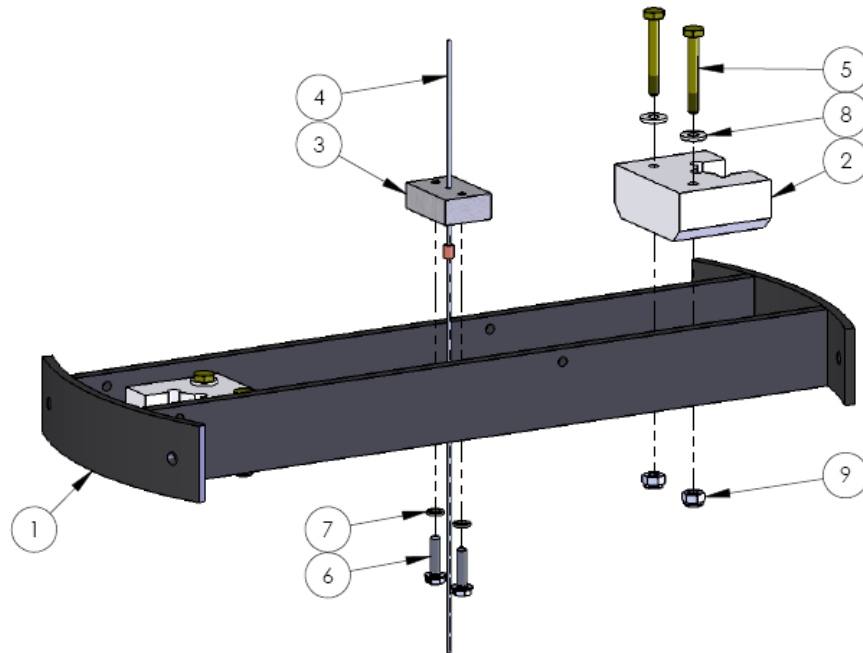

ITEM	MODEL	PART NUMBER	DESCRIPTION	QTY
1	BBX1518	000233	BAR, LIFT, 16"	1
2		000236	BUSHING, GUIDE, 16"	2
3		001619	RETAINER, CABLE	1
4		001615	CABLE, DRIVE, ASSEMBLY	1
5	BBX3542	000012	BOLT, HX, 10-32 x 1-17/32", CAD	4
6		001606	SCREW, 10-24 X 3/4", HXSL, SS	2
7		001848	WASHER, LOCK, SPLIT, #10, SS	2
8		001843	WASHER, FLAT, 0.20 x 0.50 x 0.6, SS	4
9		001685	NUT, HX, NYLOCK, 10-32, SS	4

Bambi MAX Head

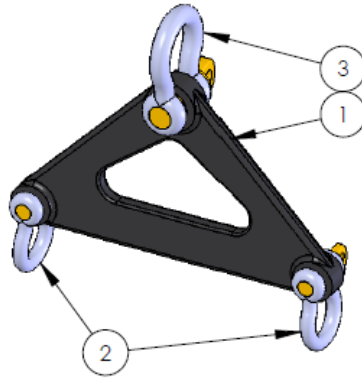

ITEM	MODEL	PART NUMBER	DESCRIPTION	QTY
1	BBX1518	007272	HEAD, SMALL	1
2		001794	SHACKLE, ANCHOR, SCREW, 3/8" GLV	2
3	BBX3542	001795	SHACKLE, ANCHOR, SCREW, 1/2" GLV	1

Bambi MAX Shell, Models 1518-1821

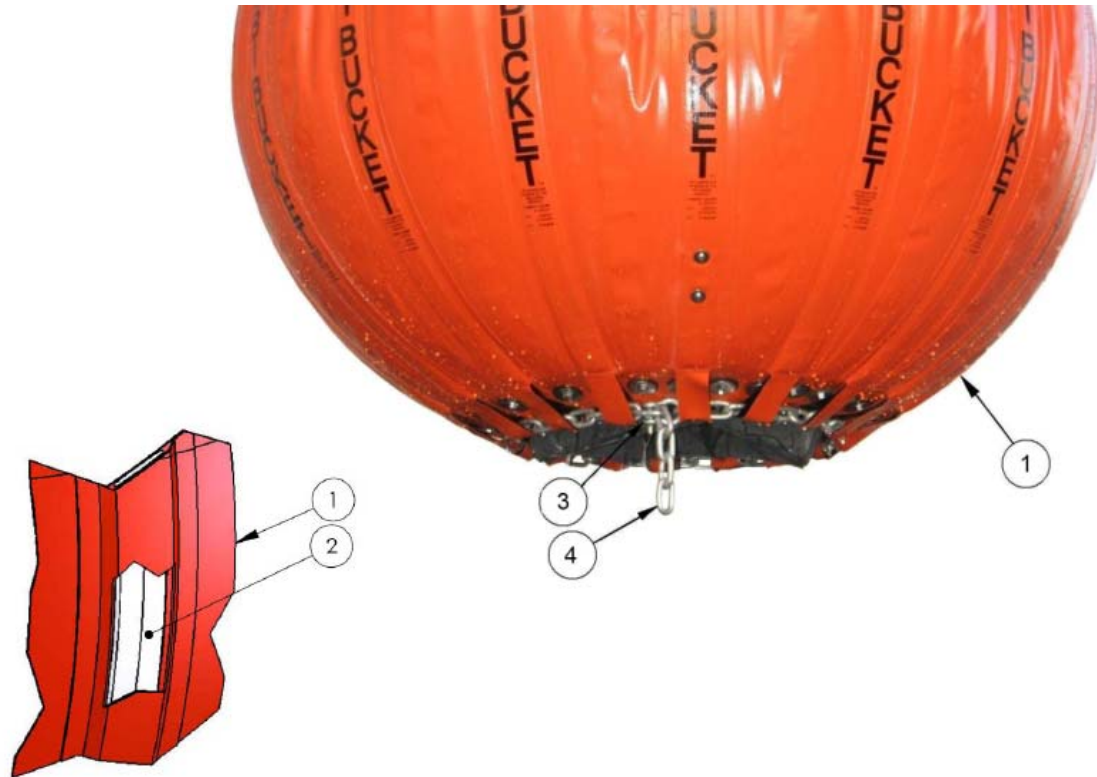

ITEM	MODEL	PART NUMBER	DESCRIPTION	QTY
1	BBX1518	008642	SHELL	1
	BBX1821	008643		
2	BBX1518	005420	BATTEN, FIBREGLASS, 31-5/8"	16
	BBX1821	005421	BATTEN, FIBREGLASS, 34-3/4"	
3	ALL	001788	SHACKLE, ANCHOR, GALV. 1/4"	1
4		003844	CHAIN, 3/16, GR30, GLV	60"

Bambi MAX Shell, Models 2024-3542

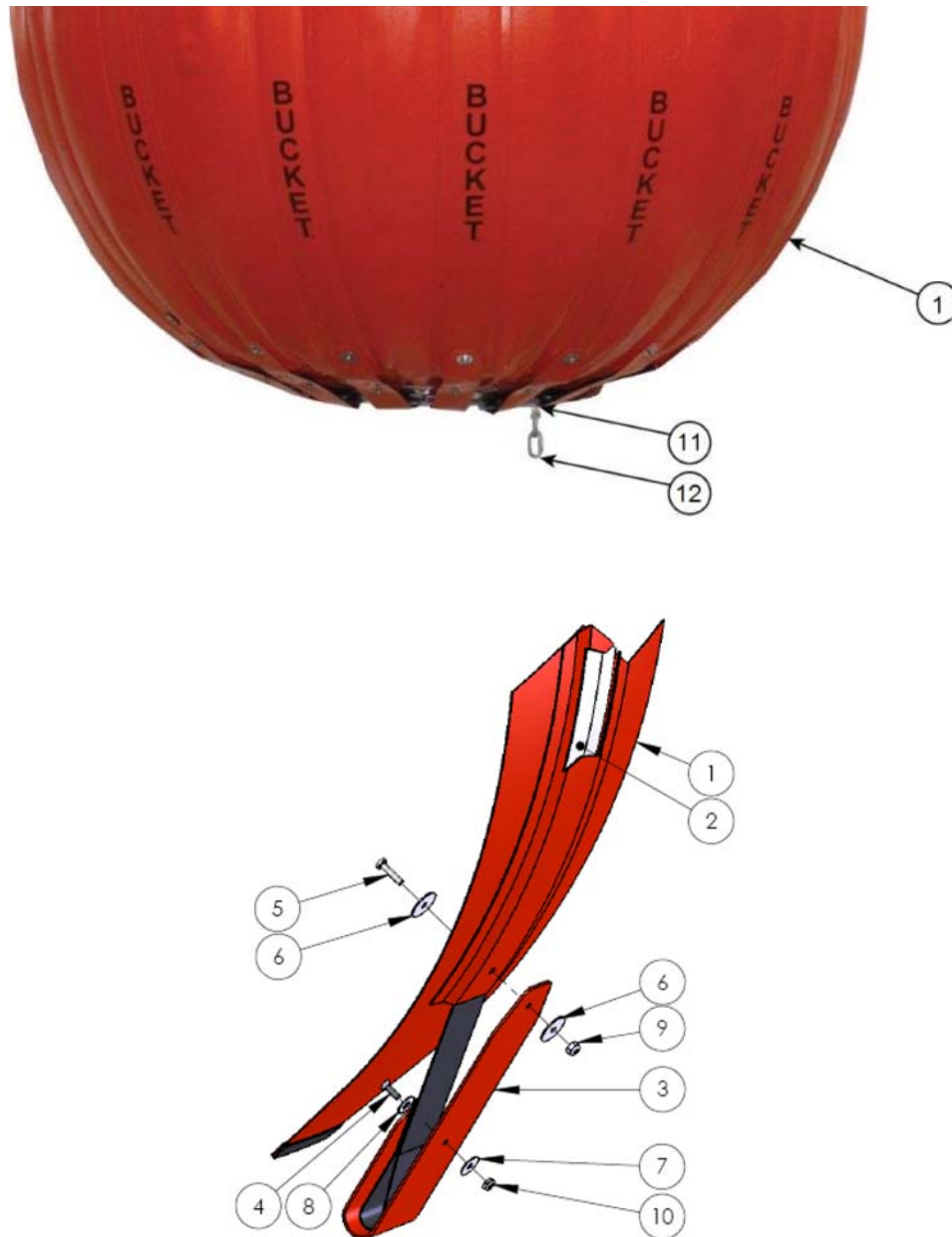

Bambi MAX Shell, Models 2024-3542 (continued)

ITEM	MODEL	PART NUMBER	DESCRIPTION	QTY
1	BBX2024	008644	SHELL ONLY	1
	BBX2024S			
	BBX2226	008645		
	BBX2732	008646		
	BBX2732S			
	BBX3542	008647		
2	BBX2024	005422	BATTEN FIBREGLASS 35-1/2"	16
	BBX2024S			
	BBX2226	005424	BATTEN FIBREGLASS 38-1/2"	
	BBX2732			
	BBX2732S			
	BBX3542	005425	BATTEN FIBREGLASS 48-1/2"	
3	BBX2024	005686	STRIP, WEAR, 19" X 2-3/8"	16
	BBX2024S			
	BBX2226			
	BBX2732			
	BBX2732S			
	BBX3542	005270	STRIP, WEAR, 16" X 2-3/8"	
4	ALL	000450	SCREW, 10-24 X 5/8, FHPH, SS	16
5		000496	SCREW, 10-24 X 7/8, PNP, SS	14
6		001856	WASHER FLAT #10 X 1 SS	28
7		001855	WASHER FLAT #10 X 3/4 SS	16
8		001833	WASHER FLAT #10 X 11/16 SS	16
9		001660	NUT, HX, NYLOCK, 10-24, SS	16
10		001661	NUT HX, NYLOCK JAM, 10-24, SS	16
11		001788	SHACKLE, ANCHOR, 1/4, SCREW, GALV	1
12	BBX2024	003846	CHAIN, GALVANIZED, GR30, 3/16"	72"
	BBX2024S			
	BBX2226			
	BBX2732	003846	CHAIN, GALVANIZED, GR30, 3/16"	
	BBX2732S			
	BBX3542	003846	CHAIN, GALVANIZED, GR30, 3/16"	

Rigging, Models 1518-1821



ITEM	PART NUMBER	DESCRIPTION	QTY
1	005467	M-STRAP, LOOP, 16"	8
2	005468	M-STRAP, STRAIGHT, 35"	8
3	005545	CABLE, SUSPENSION, PAIR	4
4	004057	LINK, CONNECTING	8

Rigging, Models 2024-3542

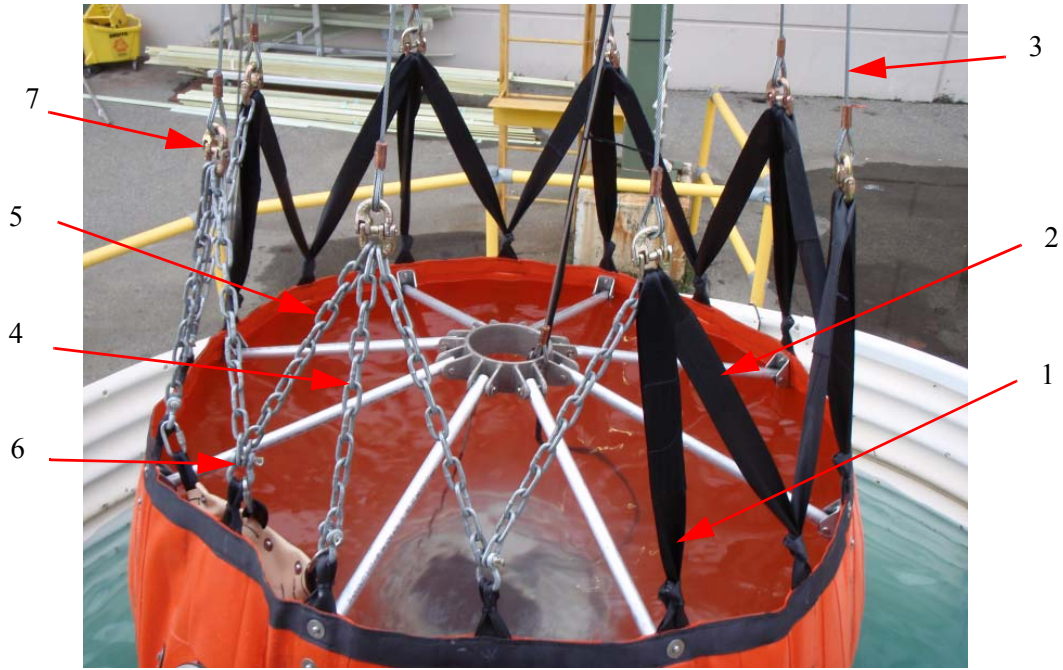

Rigging, Models 2024-3542 (continued)

ITEM	MODEL	PART NUMBER	DESCRIPTION	QTY
1	BBX2024	005469	M-STRAP, LOOP, 18-3/8"	6
	BBX2024S			
	BBX2226			
	BBX2732	005471	M-STRAP, LOOP 22-1/4"	
	BBX2732S			
	BBX3542			
2	BBX2024	005470	M-STRAP, STRAIGHT 40-3/4"	5
	BBX2024S			
	BBX2226			
	BBX2732	005472	M-STRAP, STRAIGHT, 46-1/2"	
	BBX2732S			
	BBX3542			
3	BBX2024	005547	CABLE, SUSPENSION, LINE, PAIR	4
	BBX2024S	005548		
	BBX2226	005549		
	BBX2732	008854		
	BBX2732S	005549		
	BBX3542			
4	BBX2024	005524	CHAIN, TOP, 14-1/2"	2
	BBX2024S			
	BBX2226			
	BBX2732	005526	CHAIN, TOP, 18-1/2"	
	BBX2732S			
	BBX3542			
5	BBX2024	005525	CHAIN, TOP, 16-1/2"	6
	BBX2024S			
	BBX2226			
	BBX2732	005527	CHAIN, TOP, 20-1/2"	
	BBX2732S			
	BBX3542			
6	ALL	013134	SHACKLE, ANCHOR, 5/16", SCREW, SS	5
7		004057	LINK, CONNECTING, 1/4, PLT	8

IDS System, Model 1518-1821



IDS deployed inside a Bambi bucket.

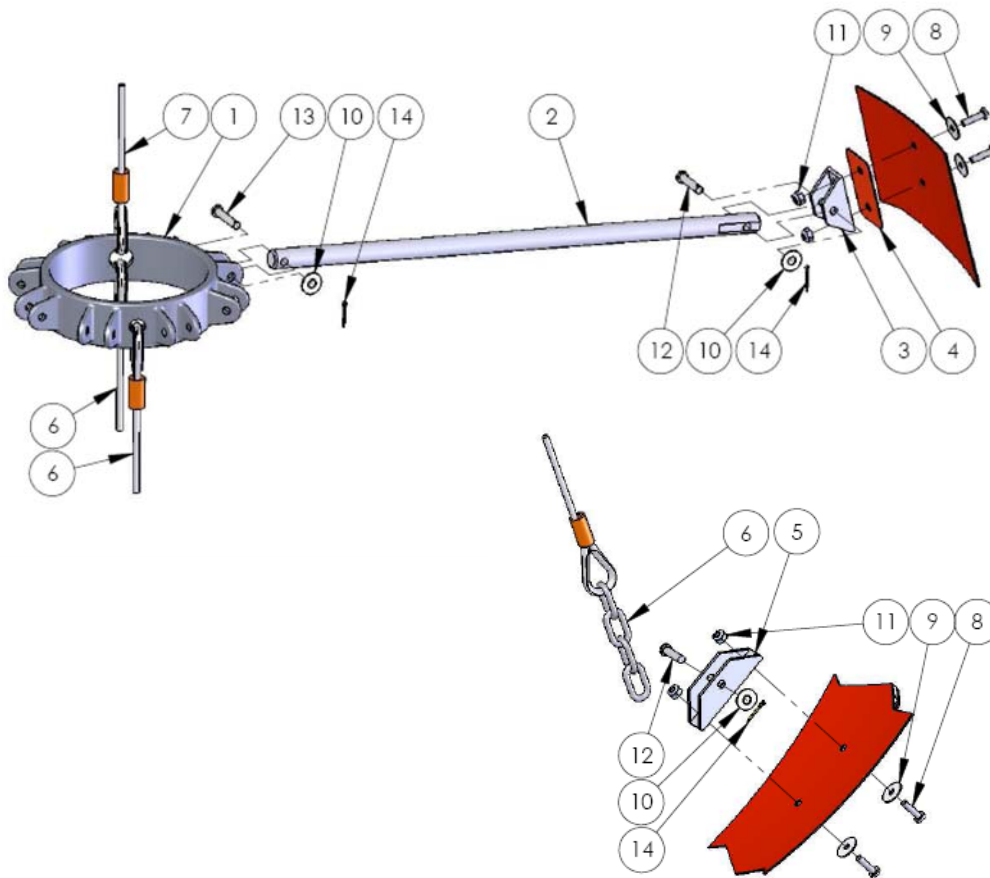

IDS System, Model 1518-1821 (continued)

ITEM	MODEL	PART NUMBER	DESCRIPTION	QTY	
1	ALL	000066	HUB 8 SPOKE	1	
		005367	HUB W / Deployment and restrainer cables		
2	BBX1518	005342	SPOKE SOLID 17-1/2	8	
	BBX1821				
3	ALL	005371	BRACKET, SHELL	8	
4		005388	PATCH, WEAR, BRACKET	8	
5		004848	BRACKET, RESTRAINER	2	
6	BBX1518	005296	CABLE, IDS, RESTRAINER	2	
	BBX1821				
7	BBX1518	005315	CABLE,IDS, DEPLOYMENT	1	
	BBX1821				
8	ALL	000495	MACHINE SCREW,10-24 X 3/4,PNPH, SS	20	
9		001855	WASHER, FLAT, #10 X 3/4,FND, SS	20	
10		001833	WASHE,R FLAT, 1/4 X 11/16 THIN, SS	18	
11		001660	NUT, HEX, NYLOCK, 10-24 HX,SS	20	
12		001703	PIN, CLEVIS, 1/4 X 1-1/8 SS	10	
13		001705	PIN, CLEVIS, 1/4 X 1 1/4 SS	8	
14			001710	PIN, COTTER, 1/16 X 3/4 PLT	18

IDS System, Models 2024-3542

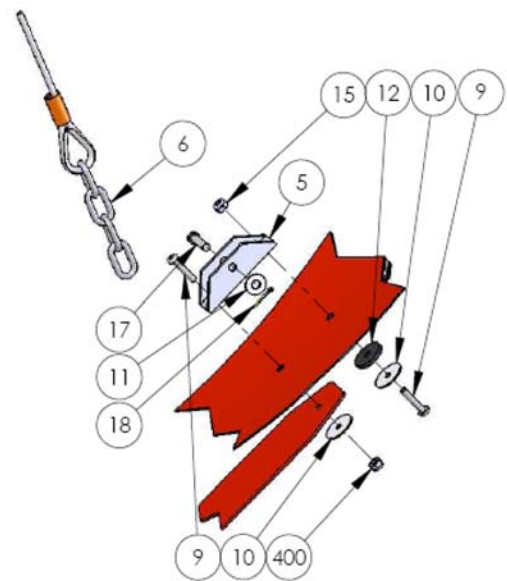
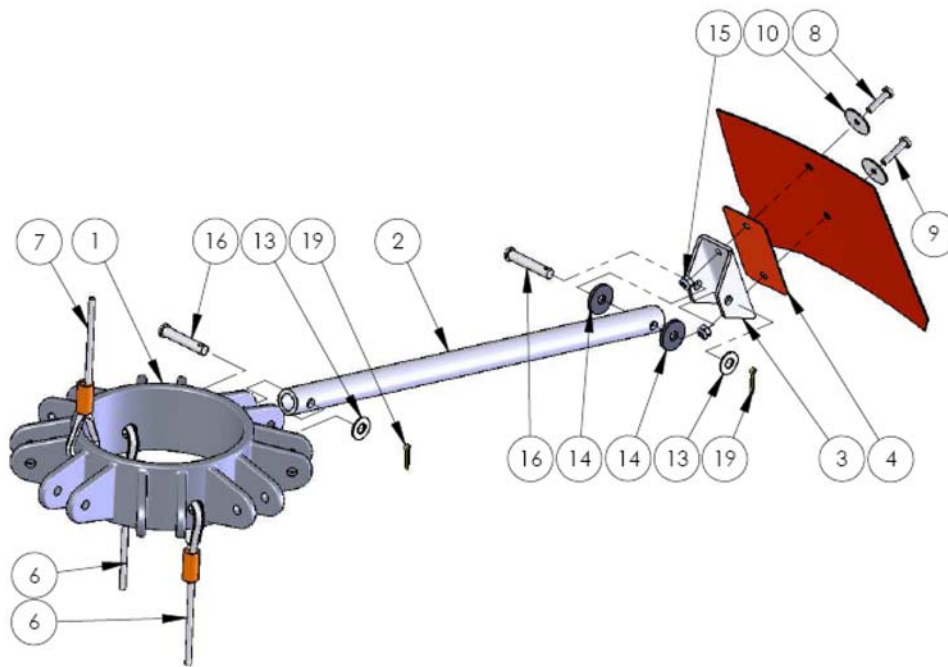

IDS System, Models 2024-3542 (continued)

ITEM	MODEL	PART #	DESCRIPTION	QTY
1	ALL	005373	HUB 8 SPOKE	1
	BBX2024	005374	HUB W/ Deployment and Restrainer Cables	1
	BBX2226	007224		
	BBX2732	005376		
	BBX3542	005377		
2	BBX2024	005343	SPOKE, TUBE, 16-3/4"	8
	BBX2024S		SPOKE, TUBE, 19-3/8"	
	BBX2226	005344	SPOKE, TUBE, 19-3/8"	
	BBX2732	005345	SPOKE, TUBE, 20"	
	BBX2732S			
BBX3542	005346	SPOKE, TUBE, 21-5/8"		
3	ALL	005385	BRACKET, SHELL	8
4		005389	PATCH,WEAR, BRACKET	8
5		004848	BRACKET, RESTRAINER	2
6	BBX2024	005297	CABLE, IDS, RESTRAINER	2
	BBX2024S			
	BBX2226			
	BBX2732	005298		
	BBX2732S			
BBX3542	005299			
7	BBX2024	005316	CABLE, IDS, DEPLOYMENT	1
	BBX2024S	006477		
	BBX2226			
	BBX2732	005317		
	BBX2732S	008828		
BBX3542	005317			
8	ALL	000496	SCREW,10-24 X 7/8, PNP, SS	8
9		000497	SCREW,10-24 X 1", PNP, SS	12
10		001856	WASHER, FLAT,3/16 X 1, FND, SS	20
11		001833	WASHER, FLAT,1/4 X 11/16, THIN, SS	2
12		001824	WASHER, 3/16 X 1 X 1/8 NEO	2
13		000068	WASHER, FLAT,5/16 X 3/4, SS	16
14		001826	WASHER, 5/16 X 1 X 1/8, NEO	16
15		001660	NUT, HX, NYLOCK,10-24, SS	20
16		001697	PIN, CLEVIS, 5/16 X 1-3/4, SS	16
17		001703	PIN, CLEVIS, 1/4 1-1/8, SS	2
18		001710	PIN, COTTER, 1/16 X 3/4 PLT	2
19		001713	PIN, COTTER, 3/32 X 3/4 PLT	16

Ballast Systems, Models 1518

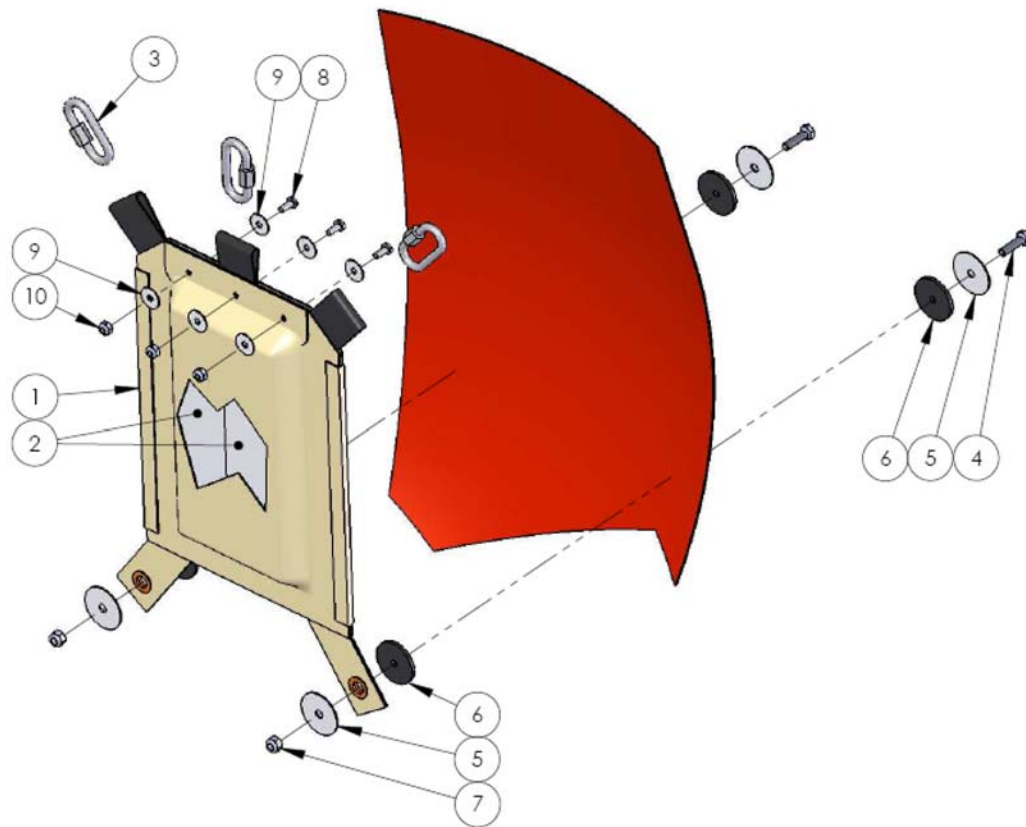

ITEM	MODEL	PART NUMBER	DESCRIPTION	QTY
1	BBX1518	005451	POUCH, BALLAST	1
2		005465	BAR, BALLAST, SQUARE,2X2X8.375 GLV	2
3		003001	QUICKLINK, 1/4,ZC-PLT	3
4		000370	BOLT, HX, 1/4-20 X 1, SS	2
5		001857	WASHER, FLAT, 1/4 X 1-1/2, SS	4
6		001828	WASHER, 7/32 X 1-1/2 X 1/8" NEO.	2
7		001662	NUT, HX, NYLOCK,1/4-20, SS	2
8		000493	SCREW, 10-24 X 1/2",PNPH, SS	3
9		001855	WASHER, FLAT, #10 X 3/4, SS	6
10		001660	NUT, HX, NYLOCK, SS, 10-24, SS	3
KIT		006184	BALLAST POUCH, ASSEMBLY, COMPLETE	1

Ballast Systems, Models 1821-3542

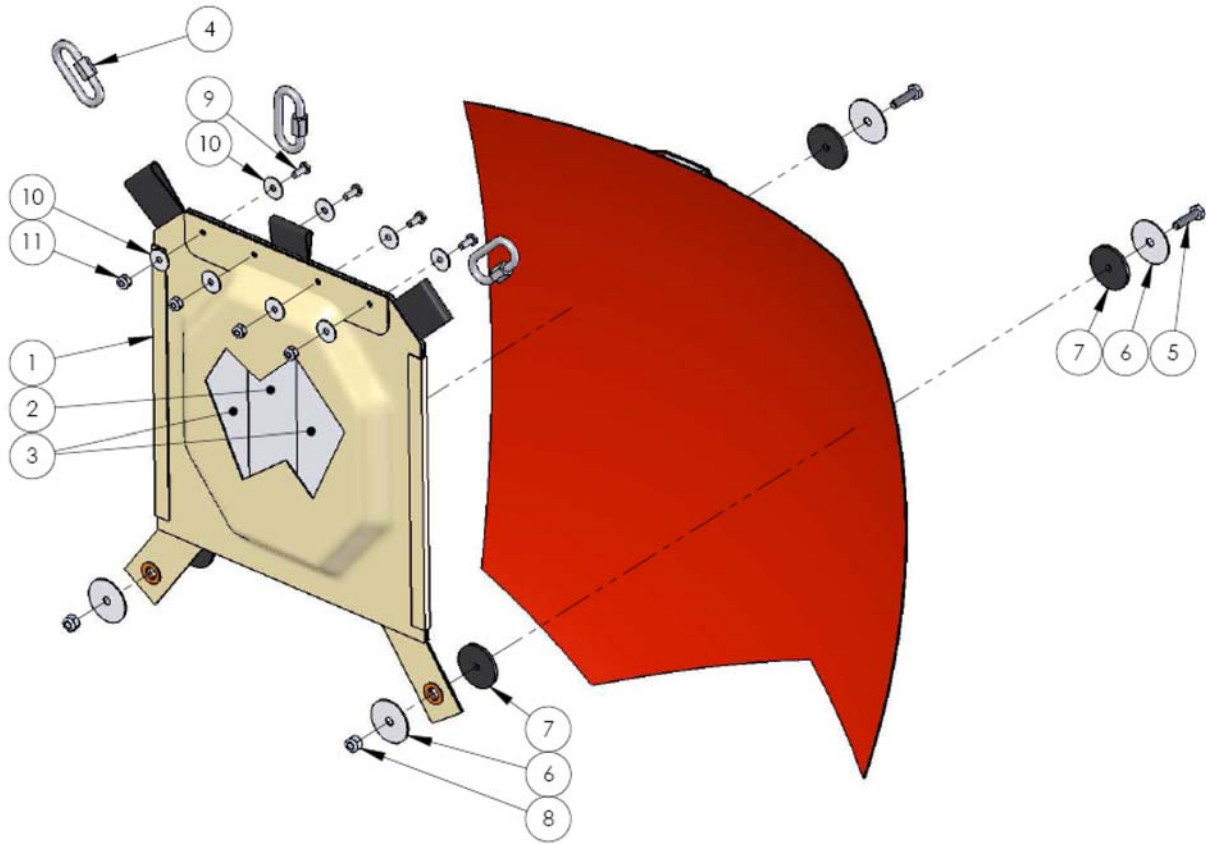

Ballast Systems, Models 1821-3542 (continued)

ITEM	MODEL	PART #	DESCRIPTION	QTY
1	BBX1821	005444	POUCH, BALLAST	1
	BBX2024	005452		
	BBX2024S			
	BBX2024PF			
	BBX2226			
	BBX2226PF	005446		
	BBX2732			
	BBX2732S			
	BBX3542	005447		
2	ALL	005465	BAR, BALLAST, SQUARE, 2X2X8.375, GALV	1
3		005466	BAR, BALLAST, TAPER, 2X2X8.375 GALV	2
4		003001	QUICKLINK, 1/4, ZC-PLT	3
5		000370	BOLT, HX, 1/4-20 X 1, SS	2
6		001857	WASHER, FLAT, 1/4 X 1-1/2, FND, SS	4
7		001828	WASHER, 7/32 X 1-1/2 X 1/8 NEO	2
8		001662	NUT, HX, NYLOCK, 1/4-20, SS	2
9		000493	SCREW, 10-24 X 1/2, PNP, SS	4
10		001855	WASHER, FLAT, #10 X 3/4, FND, SS	8
11		001660	NUT, HX, NYLOCK, 10-24, SS	4
KIT		BBX1821	006185	BALLAST, POUCH, ASSEMBLY, COMPLETE
	BBX2024	006186		
	BBX2024S			
	BBX2024PF			
	BBX2226			
	BBX2226PF	006187		
	BBX2732			
	BBX2732S			
	BBX3542	006188		

PowerFill Snorkel Drawing

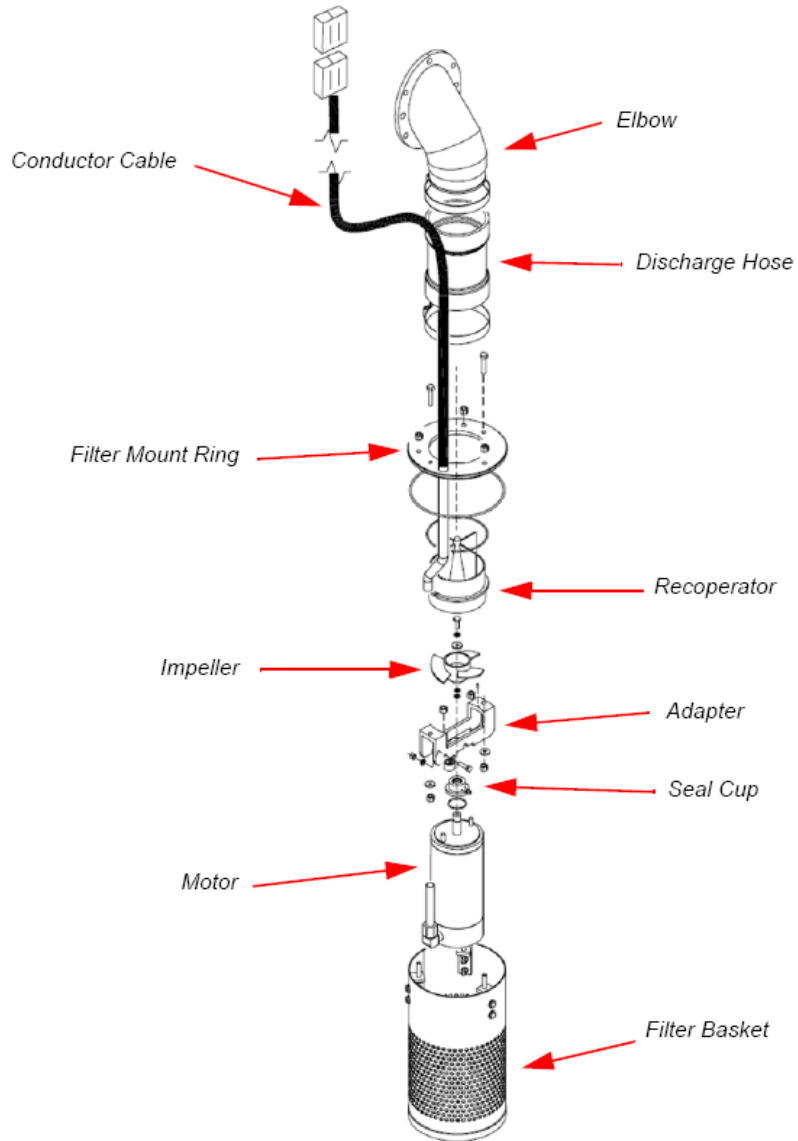

Note: PowerFill Snorkel is available on models 2024, 2732 and 3542 only.

Filter Basket Assembly

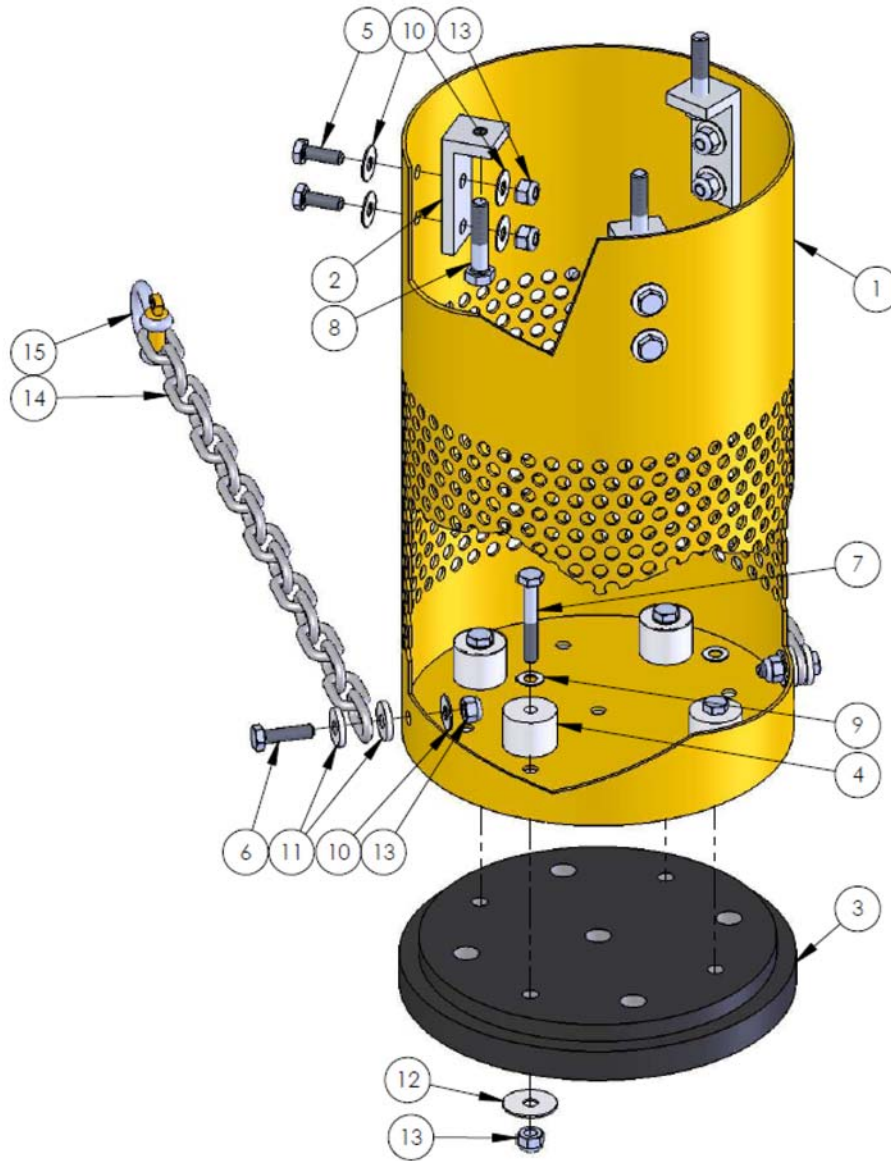

Filter Basket Assembly (continued)

ITEM	MODEL	PART #	DESCRIPTION	QTY
1	ALL	005208	BASKET, FILTER, PF2	1
2		001087	BRACKET, MOUNT, FILTERBASKET, PF2	3
3		001088	BLOCK, BUMPER, PUMP, PF2	1
4		001652	SPACER, 1/4" x 5/8" NYLON	4
5		000369	BOLT, HEX, 1/4-20 x 3/4, SS	6
6		000370	BOLT, HEX, 1/4-20 x 1, SS	2
7		000376	BOLT, HEX, 1/4-20 x 1-1/2, SS	4
8		000388	BOLT, HEX, 5/16-18 x 1-1/2, SS	3
9		001838	WASHER, FLAT, 0.27 x 0.50 x 0.032, SS	4
10		001833	WASHER, FLAT, 0.28 x 0.69 x 0.036, SS	14
11		001834	WASHER, FLAT, 0.28 x 0.75 x 0.125, SS	4
12		001858	WASHER, FLAT, 0.28 x 1.00 x 0.047, SS	4
13		001662	NUT, HEX, NYLOCK, 1/4-20, SS	12
14	2024	003844	CHAIN, 3/16", GR30, GLV.	2.6 FT
	2226			2.6 FT
	2732			3.0 FT
	3542			3.7 FT
	4453			4.0 FT
	5566			4.3 FT
15	ALL	001788	SHACKLE, ANCHOR, SCREW, 1/4, GLV	2

Motor Assembly

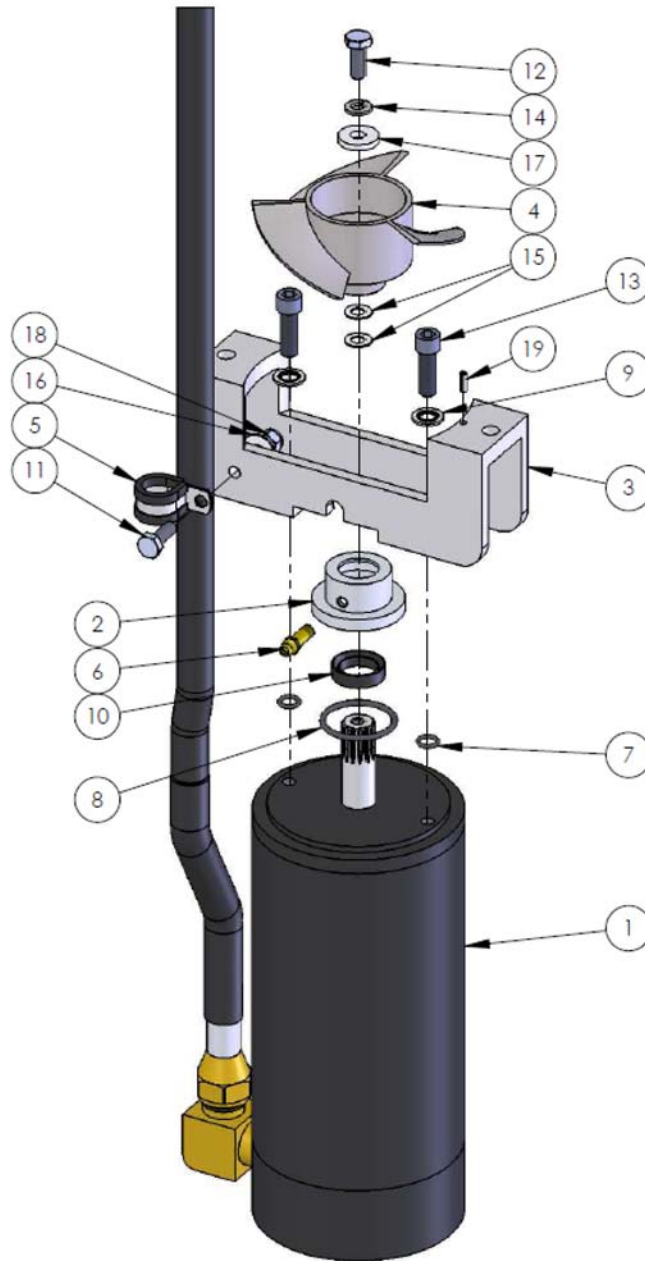

Motor Assembly (continued)

ITEM	PART #	DESCRIPTION	QTY
1	006230	MOTOR, PF2, ASSEMBLY	1
2	001059	CUP, SEAL, MOTOR	1
3	005207	ADAPTER, MOTOR, PF2	1
4	005734	IMPELLER, CAST, SS, 4", #3	1
5	002957	CLAMP, CABLE, 5/8"	1
6	005175	FITTING, GREASE, 1/4-28 x 15/16	1
7	007995	O-RING, BUNA N, #011, 50A	2
8	001890	O-RING, BUNA N, #124	1
9	001866	STATOSEAL, 5/16,PLT	2
10	006228	SEAL, LIP, 5/8 x 25 x 1/4	1
11	000369	BOLT, HEX, 1/4-20 x 3/4, SS	1
12	000533	BOLT, HEX, 1/4-28 x 3/4, SS	1
13	000432	SCREW, SC, 5/16-18 x 1, SS	2
14	001852	WASHER, LOCK, SPLIT, 1/4, SS	1
15	001838	WASHER, FLAT, 0.27 x 0.50 x 0.032, SS	2
16	001833	WASHER, FLAT, 0.28 x 0.69 x 0.036, SS	1
17	001834	WASHER, FLAT, 0.28 x 0.75 x 1.125, SS	1
18	001662	NUT, HEX, NYLOCK, 1/4-20, SS	1
19	001734	PIN, SPLIT, 1/8 x 3/8, SS	1

Recuperator

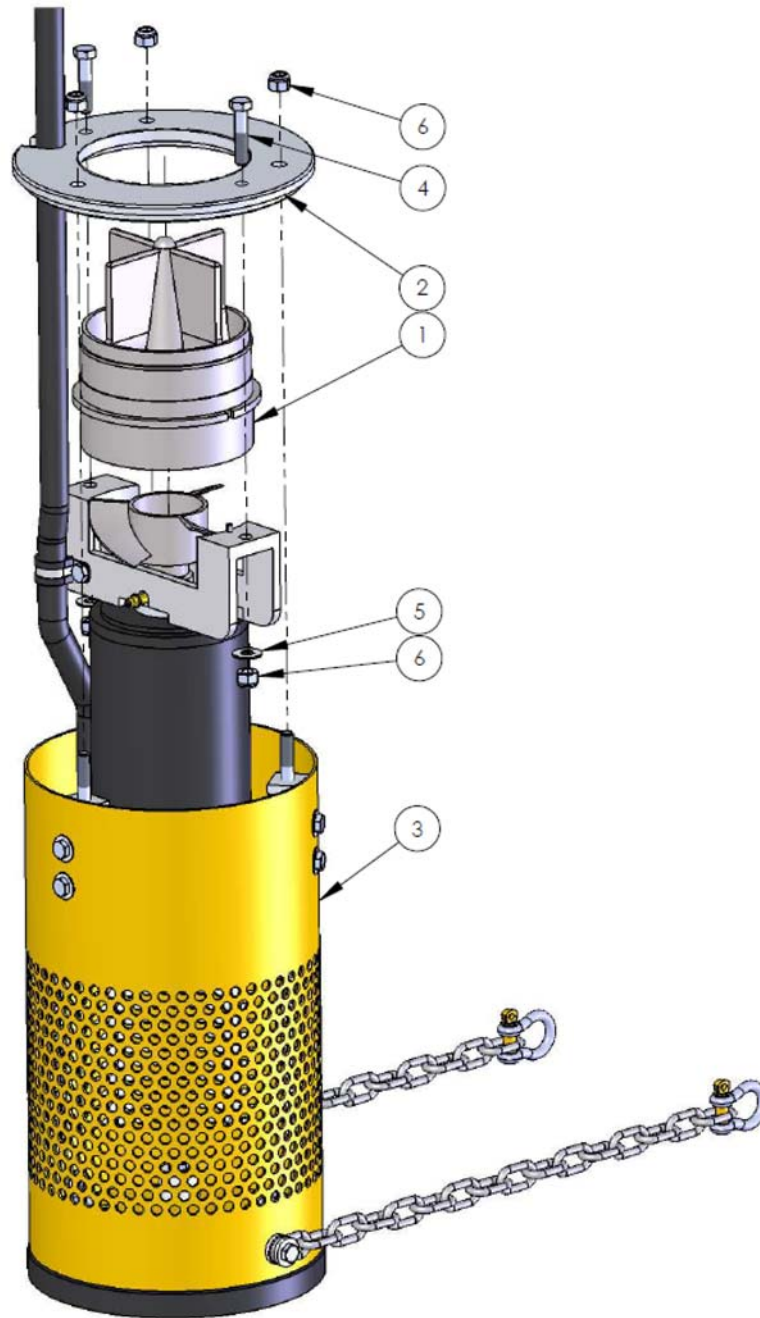

Recuperator (continued)

ITEM	PART #	DESCRIPTION	QTY
1	001085	RECUPERATOR, PF2	1
2	001084	RING, MOUNT, FILTER, PF2	1
3	001089	BASKET, FILTER, PF2, ASSEMBLY, 2024	1
	001090	BASKET, FILTER, PF2, ASSEMBLY, 2226	
	001091	BASKET, FILTER, PF2, ASSEMBLY, 2732	
	001092	BASKET, FILTER, PF2, ASSEMBLY, 3542	
	001133	BASKET, FILTER, PF2, ASSEMBLY, 4453	
	001134	BASKET, FILTER, PF2, ASSEMBLY, 5566	
4	000388	BOLT, HEX, 5/16-18 x 1-1/2, SS	2
5	000068	WASHER, FLAT, 0.34 x 0.75 x 0.047, SS	2
6	001664	NUT, HEX, 5/16-18, SS	5

Discharge Hose Assembly

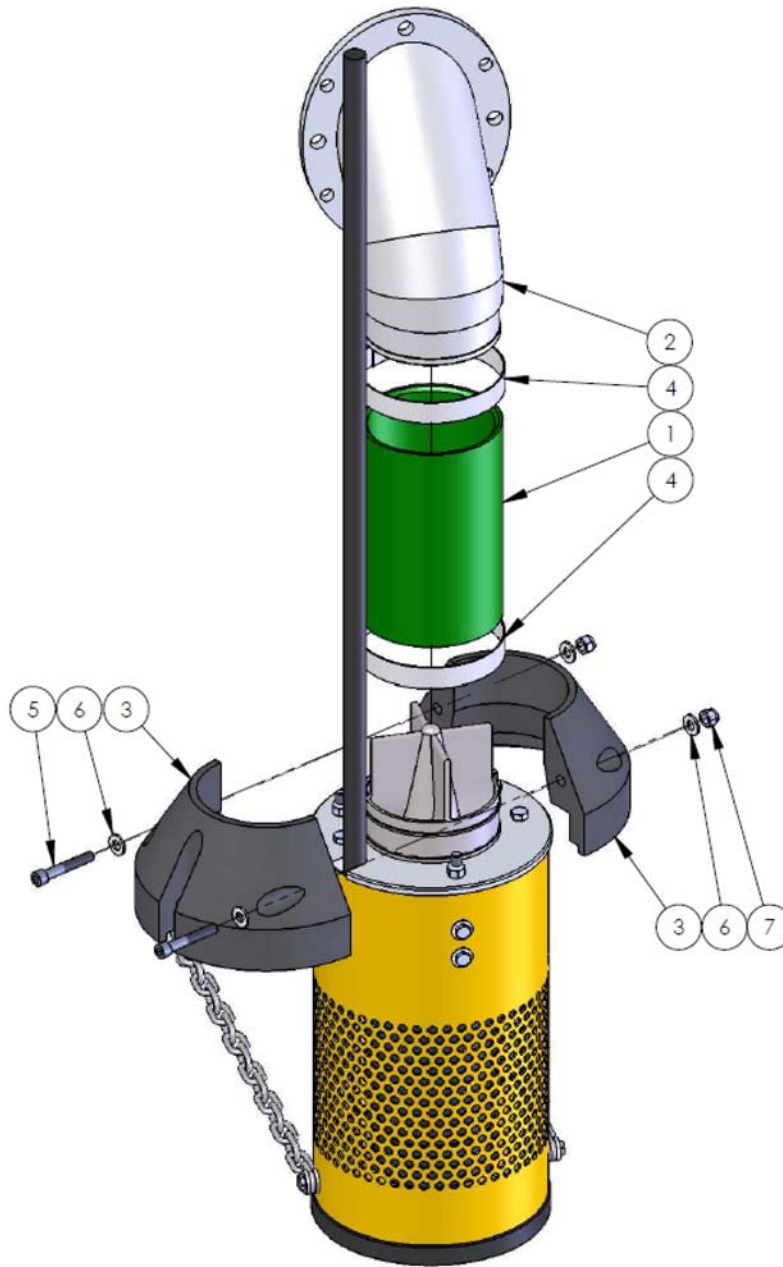

Discharge Hose Assembly (continued)

ITEM	MODEL	PART #	DESCRIPTION	QTY
1	2024	001079	HOSE, DISCHARGE, PF2, 2024-2226	1
	2226			
	2732	001081	HOSE, DISCHARGE, PF2, 2732	
	3542	001082	HOSE, DISCHARGE, PF2, 3542	
2	ALL	006231	ELBOW, PF2, FABRICATION	1
3		006413	CONE, SEGMENT, PLASTIC	2
4		003060	CLAMP, T-BOLT, 4.5", SS	2
5		006516	SCREW, SC 5/16-18 x 2, SS	2
6		006702	WASHER, FLAT. 0.34 x 0.69 x 0.08, SS	4
7		001664	NUT, HEX, NYLOCK, 5/16-18, SS	7

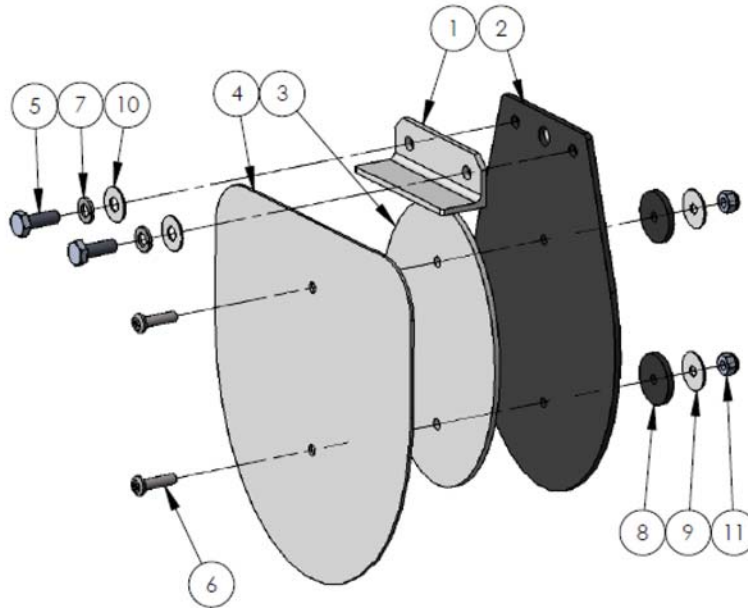
Flapper Valve Assembly

ITEM	PART NUMBER	DESCRIPTION	QTY
1	001070	BRACKET, VALVE, FLAPPER, PF2	1
2	001071	VALVE, FLAPPER, PF2	1
3	001072	SPACER, VALVE, FLAPPER , PF2	1
4	001073	DEFLECTOR, VALVE, FLAPPER, PF2	1
5	000369	BOLT, HEX, 1/4-20 x 3/4, SS	2
6	000495	SCREW, PNP, 10-24 x 3/4, SS	2
7	001852	WASHER, LOCK, SPLIT, 1/4, SS	2
8	001824	WASHER, FLAT, 3/16 x 1 x 1/8, NEO	2
9	001855	WASHER, FLAT, 0.20 x 0.75 x 0.036, SS	2
10	001833	WASHER, FLAT, 0.28 x 0.69 x 0.036, SS	2
11	001660	NUT, HEX, NYLOCK, 10-24, SS	2

Flange Assembly for Shell

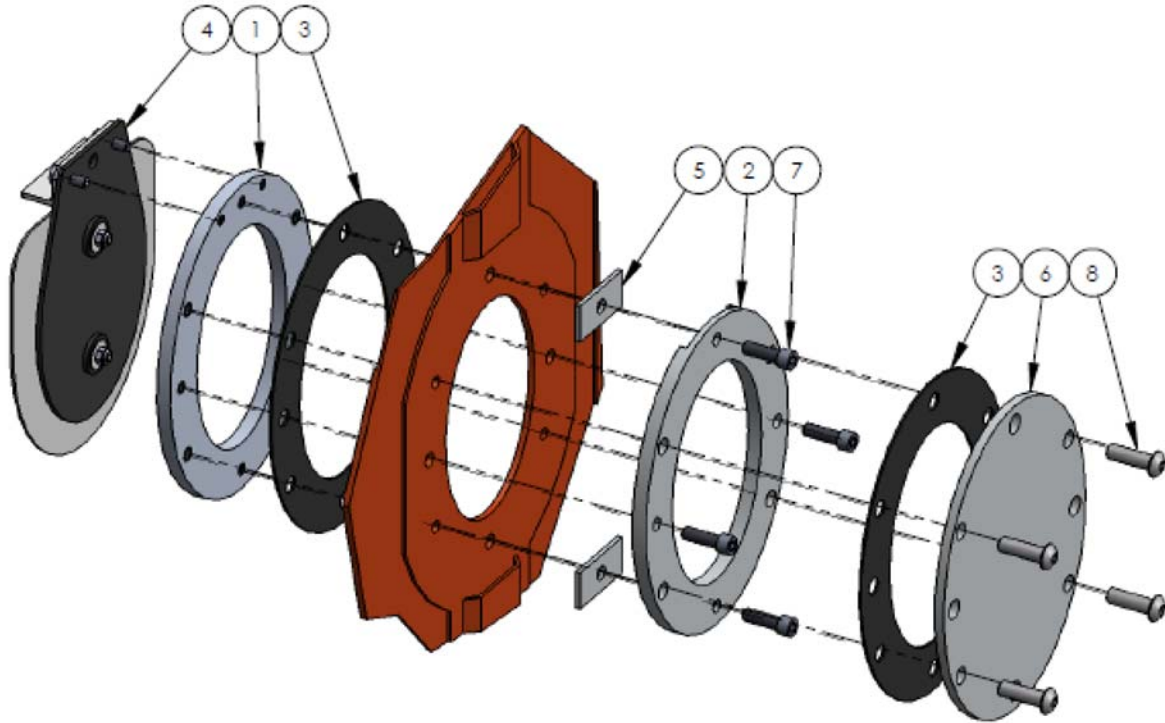

ITEM	Model	PART #	DESCRIPTION	QTY
1	All	001075	FLANGE, INNER, PF2	1
2		001076	FLANGE, OUTER, PF2	1
3		001078	GASKET, FLANGE, PF2	2
4		005737	VALVE, FLAPPER, PF2	1
5		001074	PLATE, ANCHOR, PF2	2
6		001093	PLATE, BLANK, FLANGE, PF2	1
7		000432	SCREW, SC, 5/16-18 x 1, SS	4
8		000519	SCREW, BC, 3/8-16 x 1-1/4, SS	4
9	2024	006492	BATTEN, FIBREGLASS, 1-5/8 X 6-1/2"	1
	2226			
	2732			
	3542	006619	BATTEN, FIBREGLASS, 1-5/8 X 12-1/2"	
10	2024	006491	BATTEN, FIBREGLASS, 1-5/8 X 20-3/4	1
	2226			
	2732			
	3542			
	006616	BATTEN, FIBREGLASS, 1-5/8 X 20-1/4		
	006618	BATTEN, FIBREGLASS, 1-5/8 X 27-1/2		

Bambi MAX Carrying Bags

PART NUMBER	DESCRIPTION
005598	BAG, CARRY, BAMBI MAX 1518-1821
005602	BAG, CARRY, BAMBI MAX 2024-3542

Troubleshooter Kit

PART NUMBER	DESCRIPTION	QTY.
001615	CABLE, DRIVE, ASSEMBLY	1
000236	BUSHING, GUIDE	2
002328	CLAMP, HOSE, 1/2", SS	3 FT
002332	TENSIONER, CLAMP, HOSE, 1/2" SS	4
006421	SEAL, VALVE, BOTTOM, 25"	1
006332	SEAL, VALVE, TOP, 25"	1

Section 11: Warranty

SEI Industries Ltd. (the Company) agrees to grant a warranty for a period of one year from the date of purchase of Bambi MAX systems on the following conditions:

- a) The company's sole obligation under this warranty is limited to repairing or replacing, at the company's sole discretion, any product shown to be defective.
- b) The company's products are not guaranteed for any specific length of time or measure of service, but are warranted only to be free from defects in workmanship and material for a period of one year to the original purchaser.
- c) To the extent allowable under applicable law, the company's liability for consequential and incidental damages is expressly disclaimed. **The company's liability in all events is limited to and shall not exceed, the purchase price paid.**
- d) This warranty is granted to the original purchaser of Bambi MAX systems and does not extend to a subsequent purchaser or assignee.
- e) The company must receive notification in writing of any claims of warranty from the original purchaser which must give details of the claimed defect in the product.
- f) Where the original purchaser is claiming under warranty, the product must be returned to the company for inspection with all transportation and duty charges prepaid.
- g) The warranty does not extend to any product that has been accidentally damaged, abraded, altered, punctured, abused, misused or used for a purpose which has not been approved by the company.
- h) This warranty does not apply to any accessories used with the product that are not supplied by the company and any warranty on such accessories must be requested from the manufacturer or dealer of the accessories.
- i) In the event the original purchaser does not give notice of a warranty claim, within one year of the original purchase of the product, it is understood that the purchaser has waived the claim for warranty and the purchaser and/or any subsequent purchaser must accept the condition of the product, without warranty.
- j) Any technical information supplied by the company regarding the product is not a condition of warranty but rather is information provided by the company to the best of its knowledge.
- k) There are no implied warranties nor is there any warranty that can be assumed from any representation of any person, except the company itself.

Exclusions

- l) This warranty is void if the product is not installed, used and/or maintained in accordance with the operations manual supplied by SEI.
- m) All Bambi MAX's are designed and manufactured with substantial safety margins. It is the responsibility of the user to ensure that the bucket is maintained to a safe standard.

Appendix: Drawings

Pilot Controls

RECOMMENDED COMPONENTS

ITEM	DESCRIPTION	SPECIFICATION
CB1	CIRCUIT BREAKER, 5A	MS22073-5
K1	RELAY, SPST, 10A	MS24149F
S1	SWITCH, SPST, MOMENTARY	MS24523-28
J1	CONNECTOR, PLUG	NEMA 5-15R
P1	CONNECTOR, RECEPTACLE, IP67	NEMA 5-15P, IP67
P2	CONNECTOR, PLUG, IP67	NEMA 5-15P, IP67
—	WIRE, #20 AWG	MS22759/16-20
—	WIRE, #16 AWG	MS22759/16-16

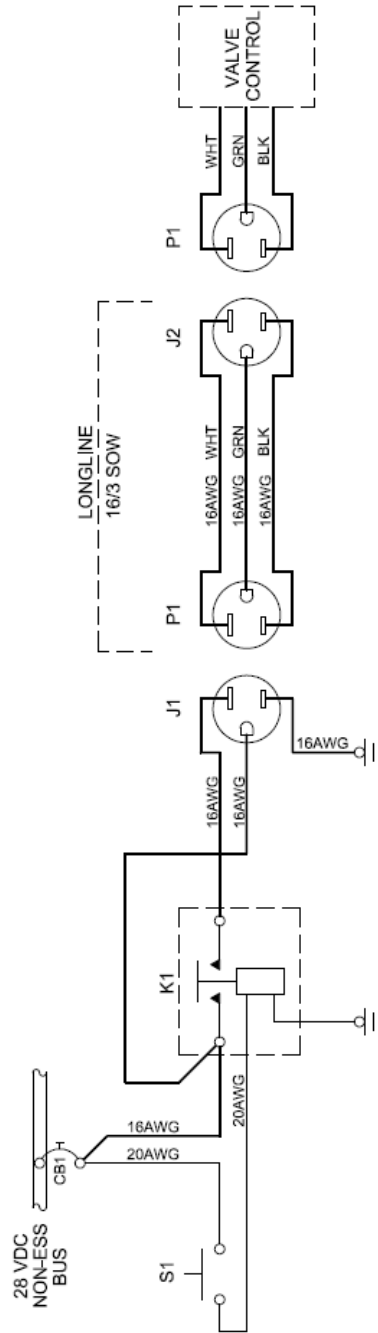

NOTES

1. THESE ARE RECOMMENDED INSTALLATION INSTRUCTIONS ONLY. ALL INSTALLATIONS TO BE DONE BY QUALIFIED PERSONNEL IN ACCORDANCE WITH APPLICABLE LOCAL REGULATIONS.
2. CONNECTION TO AIRCRAFT POWER SUPPLY DONE IN ACCORDANCE WITH FAA ADVISORY CIRCULAR AC43.13-1B AND AC43.12-2A. DO NOT CONNECT THE Bambi SYSTEM TO ANY AIRCRAFT BUS BAR THAT IS USED FOR EMERGENCY OR ESSENTIAL LOADS. AMMEND THE AIRCRAFT ELECTRICAL LOAD ANALYSIS TO ENSURE THAT THE GENERATOR CAPACITY IS ADEQUATE TO OPERATE THE SYSTEM.
3. ALL GROUNDS, SOLDERED TERMINALS, AND CRIMPED TERMINALS DONE IN ACCORDANCE WITH AIRCRAFT MANUFACTURER'S INSTRUCTIONS.

Pilot Controls, US Interagency

RECOMMENDED COMPONENTS

ITEM	DESCRIPTION	SPECIFICATION
CB1	CIRCUIT BREAKER, 5A	MS22073-5
CB2	CIRCUIT BREAKER, 50A	MS24571-50
K1	RELAY, SPST, 50A	MS24166-D1
S1	SWITCH, SPST, MOMENTARY	MS24523-28
J1	CONNECTOR, RECEPTACLE	MS3101E-24-11S
P1	CONNECTOR, PLUG	MS3107B-24-11P
J2	CONNECTOR, RECEPTACLE, IP67	NEMA 5-15R, IP67
P2	CONNECTOR, PLUG, IP67	NEMA 5-15P, IP67
—	WIRE, #20 AWG	MS22759/16-20
—	WIRE, #8 AWG	MS22759/16-8

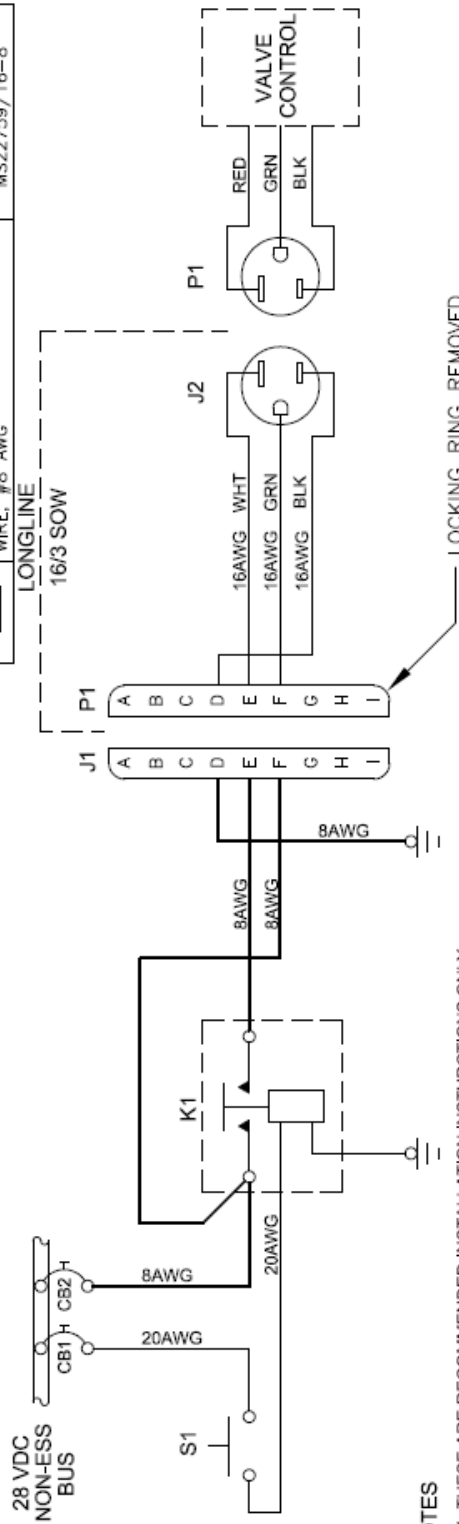

NOTES

1. THESE ARE RECOMMENDED INSTALLATION INSTRUCTIONS ONLY. ALL INSTALLATIONS TO BE DONE BY QUALIFIED PERSONNEL IN ACCORDANCE WITH APPLICABLE LOCAL REGULATIONS.
2. CONNECTION TO AIRCRAFT POWER SUPPLY DONE IN ACCORDANCE WITH FAA ADVISORY CIRCULAR AC43.13-1B AND AC43.12-2A. DO NOT CONNECT THE BAMB1 SYSTEM TO ANY AIRCRAFT BUS BAR THAT IS USED FOR EMERGENCY OR ESSENTIAL LOADS. AMMEND THE AIRCRAFT ELECTRICAL LOAD ANALYSIS TO ENSURE THAT THE GENERATOR CAPACITY IS ADEQUATE TO OPERATE THE SYSTEM.
3. ALL GROUNDS, SOLDERED TERMINALS, AND CRIMPED TERMINALS DONE IN ACCORDANCE WITH AIRCRAFT MANUFACTURER'S INSTRUCTIONS.
4. ACTUATION SWITCH MOUNTED ON THE COLLECTIVE PITCH LEVER. SWITCH MARKED "OPEN" AND SPRING-LOADED TO THE OFF POSITION.
5. IF USING THE BAMB1 MAX WITH A POWERFILL SNORKEL, USE PINS A & B IN PLACE OF PINS D & F FOR THE BAMB1 MAX ON THE 9 PIN CONNECTOR. THE POWERFILL SNORKEL MUST USE PINS D & F.

Crew Controls (using remote power supply)

RECOMMENDED COMPONENTS

ITEM	DESCRIPTION	SPECIFICATION
P1	CONNECTOR, PLUG	NEMA 5-15P
J2	CONNECTOR, RECEPTACLE, IP67	NEMA 5-15R, IP67
P2	CONNECTOR, PLUG, IP67	NEMA 5-15P, IP67
—	WIRE, #20 AWG	MS22759/16-20
—	WIRE, #16 AWG	MS22759/16-16

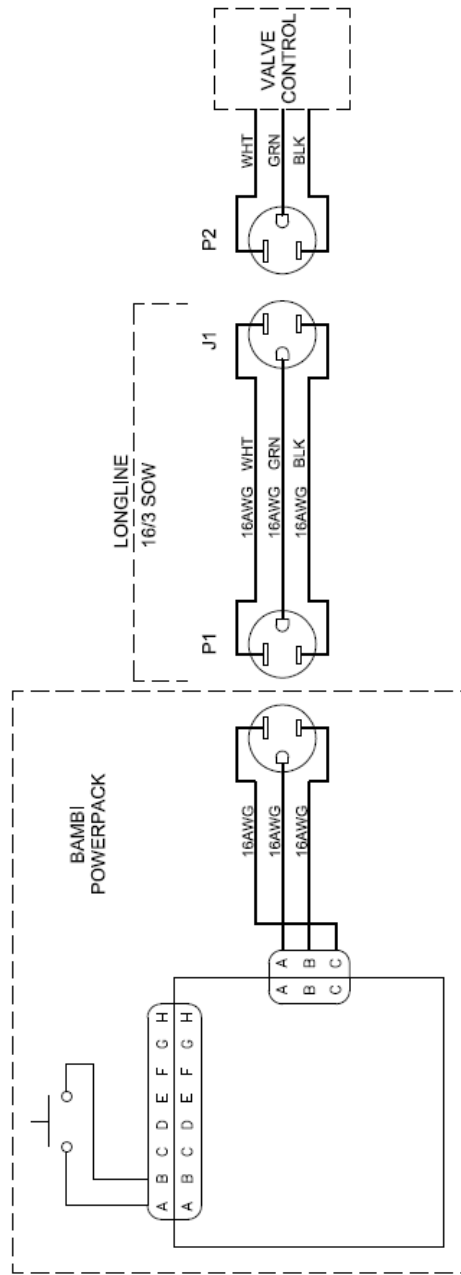

PowerFill Pump

RECOMMENDED COMPONENTS	
ITEM	SPECIFICATION
CB1	CIRCUIT BREAKER, 1A MS22073-1
CB2	CIRCUIT BREAKER, 50A MS24571-50
K1	RELAY, SPST, 50A MS24166-D1
S1	SWITCH, SPST, MOMENTARY MS24523-28
J1	CONNECTOR, RECEPTACLE MS3101E-24-11S
P1	CONNECTOR, PLUG MS3107B-24-11P
J2/P2	CONNECTOR SET, 175A APP 6326G6
J3/P3	CONNECTOR SET, 175A APP 6326G6
---	WIRE, #20 AWG MS22759/16-20
---	WIRE, #8 AWG MS22759/16-8

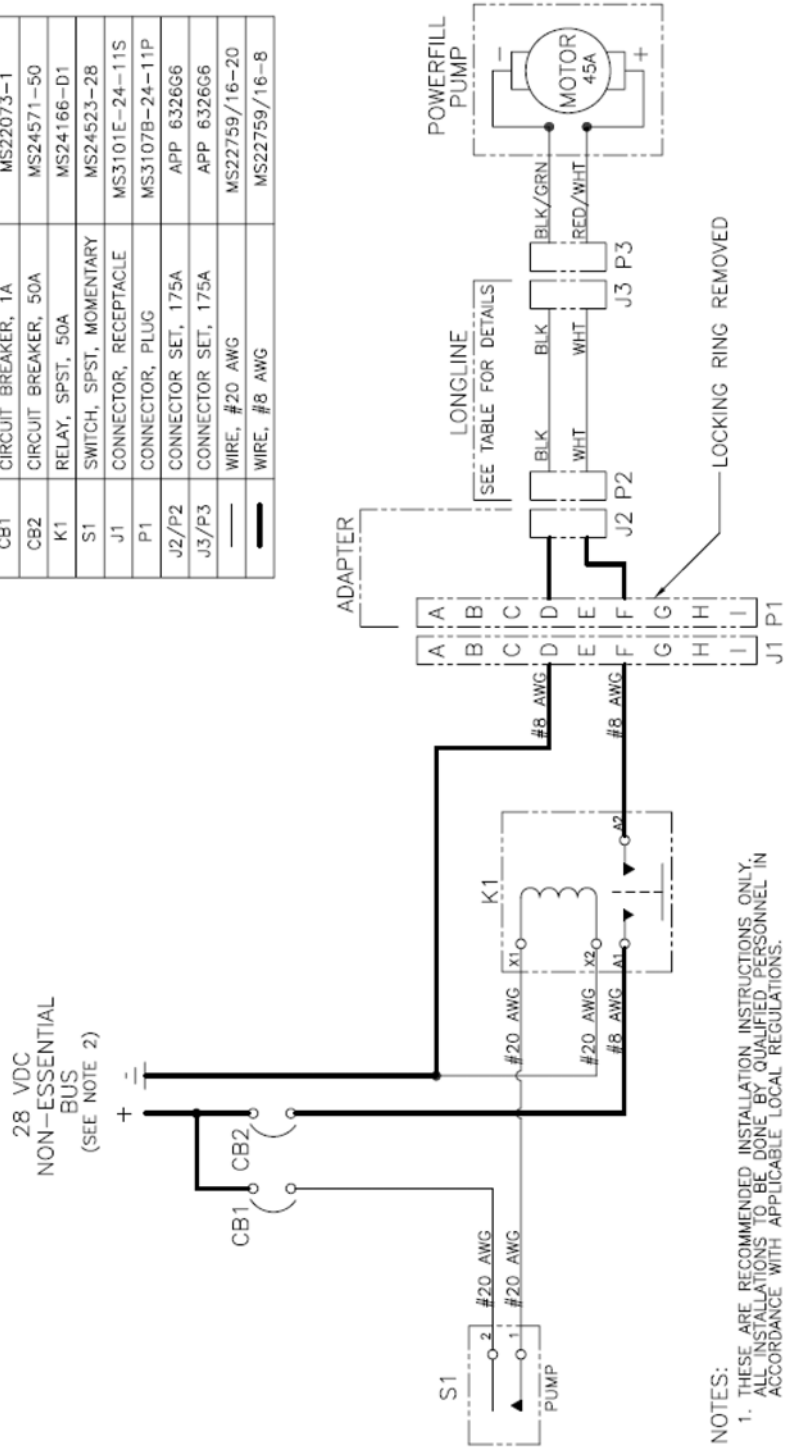

- NOTES:
1. THESE ARE RECOMMENDED INSTALLATION INSTRUCTIONS ONLY. ALL INSTALLATIONS TO BE DONE BY QUALIFIED PERSONNEL IN ACCORDANCE WITH APPLICABLE LOCAL REGULATIONS.
 2. CONNECTION TO AIRCRAFT POWER SUPPLY DONE IN ACCORDANCE WITH LOCAL REGULATIONS. DO NOT CONNECT THE POWERFILL SYSTEM TO ANY AIRCRAFT BUS BAR THAT IS USED FOR EMERGENCY OR ESSENTIAL LOADS. AMEND THE AIRCRAFT ELECTRICAL LOAD ANALYSIS TO ENSURE THAT THE GENERATOR CAPACITY IS ADEQUATE TO OPERATE THE SYSTEM.
 3. ALL GROUNDS, SOLDERED TERMINALS, AND CRIMPED TERMINALS DONE IN ACCORDANCE WITH AIRCRAFT MANUFACTURERS INSTRUCTIONS.