



BAMBI BUCKET

Models 2024 - 4453

SERVICE MANUAL

2020A

BAMBI BUCKET SERVICE MANUAL

Models 2024-4453

Version: 2020A

Part Number: 000510

Maintenance Level: Organizational (O)

PLEASE READ BEFORE USING.

This manual is applicable to the following models:

BB2024 (# 007152)

BB2024S (# 005712)

BB2024L (# 014913)

BB2226 (# 007151)

BB2732 (# 007153)

BB2732S (# 008741)

BB2732B3 (# 010805)

BB3542 (# 007155)

BB420B (# 007156)

BB4453 (# 007157)

Copies of this manual (#000510) are available from SEI.

The manual is also available on the SEI website.

Register for manual update notifications at bambiupdate@sei-ind.com

SEI INDUSTRIES LTD.

7400 Wilson Avenue

Delta, B.C. Canada

V4G 1H3

Phone: (604) 946-3131

Fax: (604) 940-9566

E-Mail: seisales@sei-ind.com

Website: www.bambibucket.com

Revision Summary

Version	Release Date	Revision Description
2019A	18-Mar-2019	<ul style="list-style-type: none">• General Revision
2020A	25-Nov-2020	<ul style="list-style-type: none">• Weight & Capacity Revision• Correct Heli-Case specifications• Warranty Revision• Error Corrections

VALIDATION OF OPERATIONS DESCRIBED IN THIS MANUAL

The maintenance operations described in this manual have been checked in manufacturer's workshops by an exact carrying out of dismantling, reassembly, test and repair instructions which are detailed in this document.

These operations are those in use at the latest revision date of the document.

Table of Contents

Section 1: Introduction	1
Bambi System Drawing	2
Dump Valve Operation	3
Control Head Operation	4
Section 2: Deploying the Bucket	7
Attaching to the Cargo Hook	7
Connecting Power	8
Longlines	8
Checking Tail Rotor Clearance	9
Instant Deployment System (IDS)	10
Section 3: Accessories	11
PowerFill Snorkel	11
Foam Injection Systems	12
Power Pack	14
Section 4: Making Adjustments	15
Adjusting the Dump Valve Udder	15
Adjusting Purse Strings	15
Section 5: Packing and Storage	17
Packing the Bucket	17
Storing the Bucket	19
Section 6: Troubleshooting Guide	21
Valve Troubleshooting	21
Control Head Troubleshooting	22
Section 7: Repair Assessment Guide	25
Overview of Repair Categories	25
Control Head Repair Criteria	26
Cables Repair Criteria	27
M-Straps/Top Chains Repair Criteria	28
IDS Repair Criteria	29
Bucket Shell Repair Criteria	30
Cinch Strap Repair Criteria	31
Valve Repair Criteria	32

Section 8: Repairs	33
Control Head Repairs.....	33
Rigging Repairs	40
Valve Repair and Replacement.....	46
Shell Repairs	50
Section 9: Specifications and Parts	57
Capacity and Weight Specifications	57
Parts	58
Section 10: Drawings	73
Section 11: Warranty	77

Section 1: Introduction

Section 1: Introduction

This manual provides information on the service and maintenance of Bambi Bucket models 2024 to 4453. This service manual also includes all parts lists and installation drawings. A separate Bambi Bucket operations manual is also supplied which should be carried on-board the helicopter.

For your own protection, and for longer bucket life, always read the instructions and warnings. Ignoring these warnings could result in personal injury, bucket damage or aircraft damage.

SEI Industries Ltd. offers complete parts supply and repair services for the Bambi Bucket. For a repair facility in your area, please contact SEI. For maintenance and repair purposes, parts diagrams and descriptions are provided in this manual.

When you are ordering parts, please provide the model and serial number of your Bambi Bucket as shown on the data tags located inside the bucket shell.



Bambi System Drawing

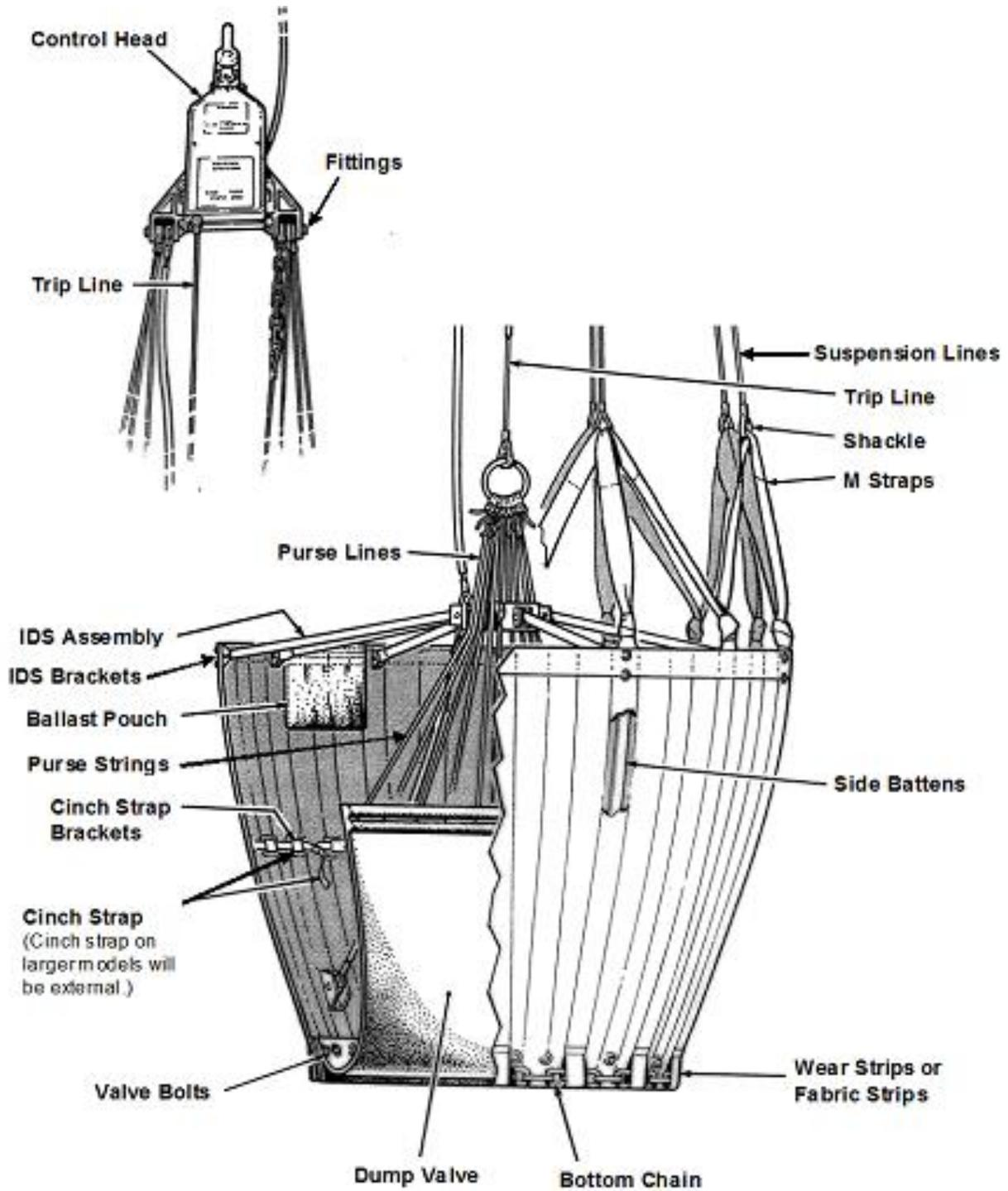

Section 1: Introduction

Dump Valve Operation

The Bambi Bucket uses a tubular fabric valve to control the flow of water exiting the bucket. The lower end of the tube has a flange which is attached to a circular opening in the bottom of the bucket.

The upper opening of the tube is flattened and has a series of grommets and purse strings laced alternately from each side. The lower end of each string terminates in a washer and a knot. Each string passes through a grommet in one side of the tube, crosses the opening, and passes through a corresponding grommet on the other side of the tube.

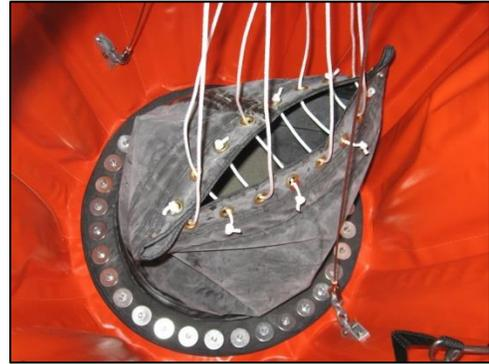

The upper ends of the purse strings are attached to a metal ring. This ring is also attached to the riser cable.

When the riser cable is pulled upwards, it pulls the ring and puts tension on the purse strings. This draws together the top faces of the tube and a rubber layer below the grommets seals the upper end of the tube.



When the bucket is dipped and filled with water, the water pressure in the bucket presses on the outside of the tube and reinforces the seal.

To open the valve, the tension on the riser cable is released, allowing the riser, purse strings and valve tube to move downwards due to the weight of the water in the bucket.

The valve tube turns inside out and extends below the bottom of the bucket. The flattened end of the tube returns to a circular shape allowing all the water to exit the bucket.

When all the water has exited the bucket, the riser cable pulls the valve tube back to its starting position.



Section 1: Introduction

Control Head Operation

The control head regulates the operation of the dump valve by raising and lowering the riser cable. The upper end of the riser is attached to the lower end of the tripline assembly. The upper end of the tripline is attached to the spring reel which winds the tripline onto a cable drum.

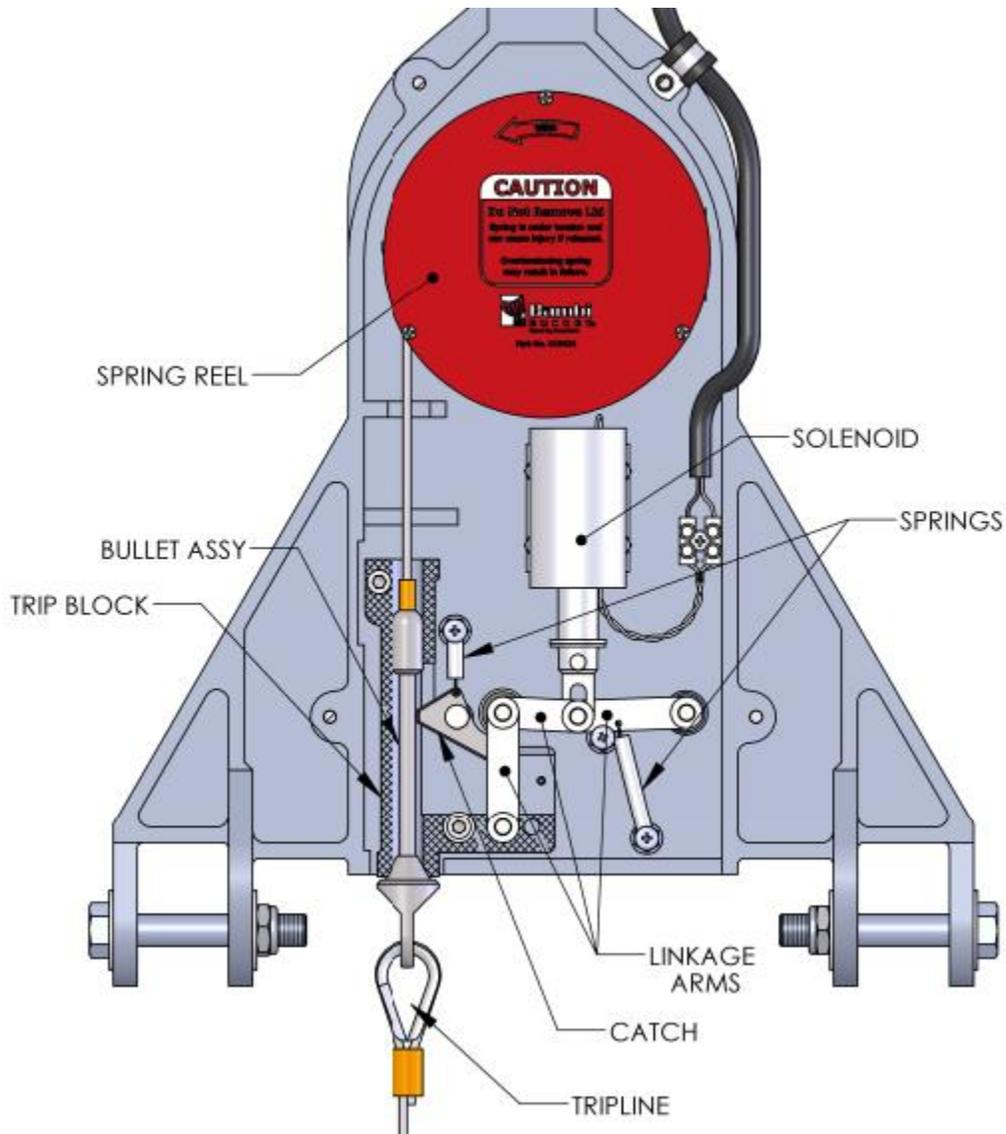

In the middle of the tripline is the bullet assembly. When there is no water in the bucket, the spring reel winds up the tripline until the lower end of the bullet assembly reaches its limit on the bottom of the trip block.

WARNING

Do not remove the cover on the control head while operating the Bambi Bucket. With the cover removed, the tripline safety keeper is no longer functional. Without the safety keeper, the tripline could separate and cause a tail rotor strike resulting in severe injury or death.

Section 1: Introduction

When the bucket is filled with water, the pressure pulls down on the valve, riser and tripline until the upper end of the bullet assembly engages the mechanical catch. The mechanical catch is locked in place by the linkage arms.

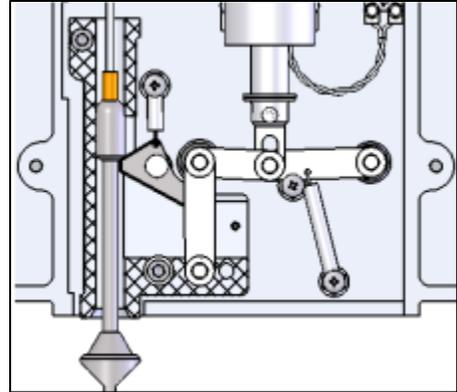

To dump the valve, an electrical signal is sent to the solenoid which pulls up on the linkage arms and unlocks the catch.

The weight of water in the bucket pulls down on the valve, riser and tripline. The upper end of the bullet assembly pushes past the spring-loaded catch and the tripline unwinds from the spring reel allowing the dump valve to fully open.

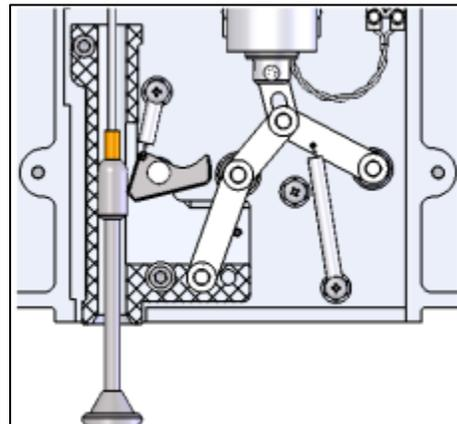

When the electrical signal to the solenoid is removed, springs return the linkage arms, solenoid, and catch to their original positions.

When all of the water has left the bucket, the only downward force remaining on the tripline is the weight of the valve and riser. This weight is overcome by the spring reel which winds up the tripline, riser and valve.

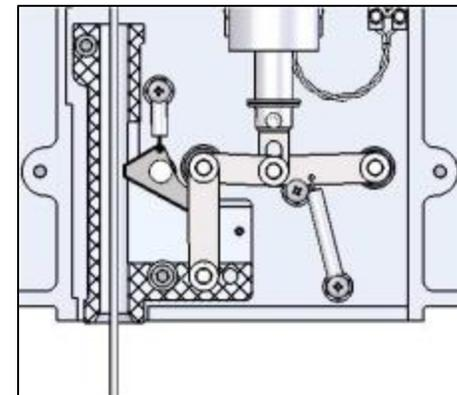

As the bullet assembly re-enters the head, it pushes past the spring loaded catch. The tripline continues to retract into the spring reel until the lower end of the bullet assembly reaches its limit on the trip block. The head is now latched and ready for another fill.

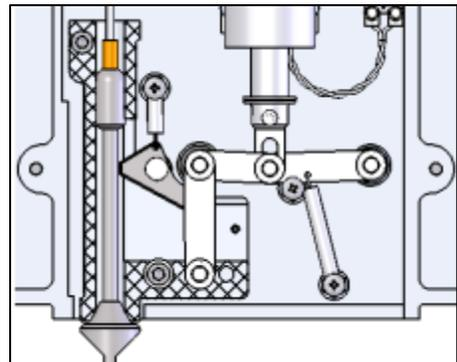

THIS PAGE INTENTIONALLY LEFT BLANK

Section 2: Deploying the Bucket

Section 2: Deploying the Bucket

Attaching to the Cargo Hook

The Bambi Bucket is rigged for a lateral cargo hook. Correct attachment is indicated when the name plate on the control head faces forward in flight. This ensures that the ballast on the Bambi will face forward in flight.

CAUTION

The Bambi Bucket may not be suitable for a direct hook-up to the cargo hook. The actual hook-up will be different for various aircraft and operators must comply with all instructions and bulletins supplied by the aircraft manufacturer. It is the operator's responsibility to ensure that the Bambi Bucket is correctly fitted to the helicopter.

Control Head Orientation

The control head has a moveable yoke which can be rotated by 90 degrees. The yoke is machined to orient in either direction. If your helicopter has a longitudinal hook, rotate the shackle yoke by 90 degrees. This will place the name plate on the control head forward in flight.

For this style of head, if using a swivel hook, always operate in the locked position to assure that the ballast is always facing forward in flight.



In some cases, where the cargo hook is too large for the standard shackle, a second larger shackle can be used. If the shackle is too large, it may cause the power cable to tangle, pulling apart the breakaway plug.



WARNING

Ensure that all shackles are rated with a minimum safety factor of five for the gross weight of the bucket as shown on the data plate.

Section 2: Deploying the Bucket

Connecting Power

The Bambi Bucket requires a 24 VDC power source capable of supplying 5 A.

There are four types of suggested wiring installations (see *Section 10: Drawings*):

1. **Pilot control:** The control is wired into the pilot's control column through a relay.
2. **Pilot control (US InterAgency):** The control is wired into the pilot's control column through a 50 ampere relay as per US interagency regulations. This system can also be used to control a heli-torch, etc.
3. **Crew control:** A crew member or pilot controls the dumping of the bucket using power from the helicopter and a remote switch.
4. **Crew control (remote power supply):** A crew member or the pilot controls the dumping of the bucket using a battery pack to supply the power to the remote switch.

The Bambi Bucket's electrical supply is connected through a breakaway plug. The purpose of the plug is to offer a clean "breakaway" if the Bambi Bucket has to be jettisoned from the aircraft in an emergency. To ensure that wind action does not separate the plug, it is suggested that the plug be lightly taped together with vinyl tape while in use.

To check for continuity in the connections, push the momentary contact switch. A clicking sound should be heard from the control head.

NOTICE

To operate the solenoid and release the water, a momentary contact switch is used. The solenoid has a 10% duty cycle. Operating the solenoid continuously will result in solenoid failure.

Longlines

NOTICE

If using a longline, the minimum recommended length is 50 ft (15 m).

When using a longline, select the correct gauge of control cable from the following chart.

Wire Length		Wire Type	Connectors	
Feet	Meters		Top	Bottom
0–100	0–30	14/2 SOW	NEMA 5-15P	NEMA 5-15R
101–200	30–61	12/2 SOW	NEMA 5-15P	NEMA 5-15R

When using a synthetic rope longline, it is recommended that a protective cover be used and the control cable be inserted at the time of manufacture. However, if this is not feasible, it is recommended to secure the cable using tape at 3 ft (1 m) intervals along the longline. It is not recommended to use zip ties as they tend to damage the cover and longline. When attaching the control cable, allowances must be made for any stretch in the load bearing line. When the control cable is taped to the outside of the longline, the flight characteristics can change.

Section 2: Deploying the Bucket

Checking Tail Rotor Clearance

WARNING

Using a Bambi Bucket with insufficient tail rotor clearance could result in a tail rotor strike which could result in serious injury or death.

When a Bambi Bucket is attached directly to the helicopter cargo hook or attached using a longline less than 50 ft (15 m) in length, it is important to confirm that there is adequate tail rotor clearance. Before using the Bambi Bucket, check the tail rotor clearance.

1. Determine the tail rotor length by measuring the distance from the cargo hook to the closest point on the helicopter tail rotor.
2. Determine the bucket overall length from the following chart:

Model	Overall Length	
BB2024	20'- 1"	6.13 m
BB2024S	15'- 10"	4.82 m
BB2024L	22'- 4"	6.81 m
BB2226	15'- 10"	4.82 m
BB2732	23'- 0"	7.00 m
BB2732B3	16'- 5"	5.00 m
BB2732S	15'- 2"	4.63 m
BB3542	23'- 8"	7.22 m
BB420B	23'- 8"	7.22 m
BB4453	23'- 9"	7.25 m

*Lengths are accurate to within 1%. Specifications subject to change.
If a firesock is used, add 8" (0.20 m) to the above dimensions*

To confirm the bucket overall length, stretch out the bucket on the ground, pulling the suspension cables taut. Measure the distance from the shackle on the head to the bottom of the extended dump valve. If a firesock is attached, measure to the bottom of the firesock.

3. The tail rotor clearance is equal to the tail rotor length minus the bucket overall length.
4. **The tail rotor clearance must be a minimum of 6" (0.15 m).**

If the tail rotor clearance is insufficient, shorter suspension lines, riser, ring and restrainer, and deployment lines must be used and can be ordered from SEI. Please specify the model and serial number when ordering parts.

Section 2: Deploying the Bucket

Instant Deployment System (IDS)

The instant deployment system uses a hub and spoke mechanism to automatically expand the mouth of the bucket as soon as the weight of the Bambi Bucket is taken up by the suspension cables.

When the bucket is full, the IDS deployment cable and IDS restrainer cables should be slack as they should not bear any load. Their function is to position the hub and spoke mechanism to hold the bucket open.

To deploy the IDS on the ground, reach into the bucket, grasp the hub of the IDS and pull outward fully until the two restraining cables from the hub to the lower bucket shell are tight.

The IDS restraining cables are set at the factory and normally should not require any adjustment.



Section 3: Accessories

Section 3: Accessories

Accessories are optional. Not included with the Bucket.

PowerFill Snorkel

PowerFill Snorkel is a system which allows partial or complete bucket fills from a range of previously inaccessible water sources as shallow as 18” (0.46 m) including streams, ponds and low profile dip tanks. It is available for bucket models 2024 – 4453.

The PowerFill Snorkel is an externally mounted pump consisting of a flange assembly and a pump assembly. The flange assembly is permanently installed into the bucket and includes a flapper check valve to prevent water from flowing back through the pump when the pump is not running. Multiple flanges can be installed on several buckets to accept the same pump unit.

The pump assembly is connected to the flange assembly with a camlock fitting which allows the pump to be quickly removed for ease of transport.



The PowerFill snorkel has an electrically driven pump with an optimum output of 425 USG/min (27 L/s). The pumps require a 28 VDC power source capable of supplying 45 A. This supply must be from the aircraft non-essential bus. The installation shall be done in accordance with FAA Advisory Circulars AC43.13-1B and AC43.13-2A and any applicable aircraft manufacturer's instructions.

WARNING

Do not connect the PowerFill Snorkel system to any aircraft bus bar that is used for emergency or essential loads. Before installation, do an electrical load analysis to ensure that the generator capacity is adequate to operate the system and amend the aircraft electrical load to the new requirements.

Power is transmitted through a waterproof cable to the pump motor. At the top end of the cable, a quick disconnect plug will separate with minimal force in the event of a load jettison. See the following chart for recommended longline wire sizes for the PowerFill Snorkel.

Wire Length		Wire Type	Connectors	
Feet	Meters		Top	Bottom
0–100	0–30	2 x #6 TEW	APP 6326G6	APP 6326G6
101–200	30–61	2 x #4 WELDING	APP 6326G6	APP 6326G6

The pump motor, impeller and housings are contained within a circular steel filter basket. The filter basket serves to protect the components from impact damage while also acting as a debris screen.

The pump is fully waterproof in operation to a depth of 10 ft (3.0 m) and can run “dry” without damage. It has a standard hydraulic grease nipple provision to extend the life of the motor output shaft seal.

Section 3: Accessories

Foam Injection Systems

Sacksafoam is a foam injection system that uses a pump to dispense a controlled amount of foam concentrate from a reservoir into the water in the bucket. The operation of the Sacksafoam is controlled by the pilot through a control unit, which is mounted in the cockpit. There are two models of Sacksafoam available depending on the location of the foam concentrate reservoir.

Sacksafoam Bladder

The Sacksafoam Bladder uses a collapsible reservoir located in the bucket. An internal check valve stops water from flowing into the bladder and insures that foam is dispensed only while the injection pump is operating. Because the foam in the bladder displaces the water in the bucket, the total gross weight is always constant.

The Sacksafoam bladder interfaces with the Sacksafoam controller. Dispensing can be controlled directly from the controller screen or a remote switch.



Bucket Model	Part #	Reservoir Capacity			Gross Weight		Power
		Imp Gal	USG	Liters	lb	kg	
BB2024	004339	25	30	114	268	122	5 A @ 28 VDC
BB2024S							
BB2024L							
BB2226							
BB2732							
BB2732B3							
BB2732S							
BB3542							
BB420B							
BB4453							

See the following chart for recommended longline wire sizes for the Sacksafoam Bladder.

Wire Length		Wire Type	Connectors	
Feet	Meters		Top	Bottom
0–100	0–30	14/2 SOW	NEMA 1-15P	NEMA 1-15R
101–200	30–61	12/2 SOW	NEMA 1-15P	NEMA 1-15R

Section 3: Accessories

Sacksafoam Heli-Case

The Sacksafoam Heli-Case is a self-contained unit that can be stowed onboard the helicopter. The foam concentrate is stored in a 20 USG tank inside a large plastic case with provision for an extra 5 USG container. The case is designed to prevent foam from contacting the helicopter.

The Sacksafoam Heli-Case interfaces with the Sacksafoam controller which can be mounted directly in control panel or externally by using the supplied blanking plate and harnesses. Dispensing can be controlled directly from the Sacksafoam controller screen or using the remote control grip.



The Sacksafoam Heli-Case can also interface with the Bambi Bucket, allowing the bucket to be actuated using the trigger on the remote control grip.

Bucket Model	Part #	Reservoir Capacity			Gross Weight		Power
		Imp Gal	USG	Liters	Lb	Kg	
BB2024	012743	19	23	87	267	122	15 A @ 28 VDC
BB2024S							
BB2024L							
BB2226							
BB2732							
BB2732B3							
BB2732S							
BB3542							
BB420B							
BB4453							

Foam Compatibility

The Bambi Bucket is designed to be effective with foam. All materials used in the manufacture of the Bambi Bucket are resistant to the chemical action of foam.

NOTICE

After using foam or retardant in the bucket, it should be washed with fresh water to remove all residue. Foam and retardant can accelerate corrosion and degradation of materials if not removed.

Section 4: Making Adjustments

Power Pack

The Bambi Power Pack is a 24VDC, rechargeable power supply that allows the Bambi Bucket or Bambi MAX to be operated independently of the aircraft power.

The plastic case contains a NiMH battery pack and battery charger. The charger operates on either a 120V/60Hz or 240V/50Hz mains power supply. Two power cords are included. One has a NEMA 1-5P plug and the other has a CEE7/16 Europlug.

The Power Pack also includes a dump switch harness to operate the bucket valve, a bucket wiring harness to connect to the bucket, and a grounding harness to ground the system to the airframe to eliminate static charge buildup. All of the wiring harnesses and power cords are stowed inside of the case.

A manually operated circuit breaker located on the front of the case can be used to disconnect the battery power from the bucket harness.



Bucket Model*	Power Pack Part #	Specifications			Gross Weight	
		Type	Output	Capacity	lb	kg
BB2024*	008282	NiMH	24 VDC	3 AH	16	7
BB2226						
BB2732*						
BB3542						
BB420B						
BB4453						

*Applicable to models of the same size denoted with suffix 'S', e.g., BB2732S.

Section 4: Making Adjustments

Adjusting the Dump Valve Udder

Udder refers to the amount that the dump valve bulges out below the bucket shell, when the bucket is full. A properly adjusted dump valve will have a maximum of 2" (50 mm) of udder.

Too much udder will add to the volume and thus the weight of the bucket. Too little udder will result in the valve leaking and premature wear on the purse strings.



To adjust the udder, change the length of the tripline by adjusting it at the tripline adjustment chain.

If a new tripline is installed, first install it at the same point on the adjustment chain and then test the dump valve in use. Remember to secure the adjustment shackle with a lock wire or tie wrap first. It is impossible to judge udder with an empty bucket on the ground.



Adjusting Purse Strings

Adjustment of the purse strings in the dump valve is important to ensure a good seal at the neoprene lips of the valve mouth. The purse string adjustment is set and tested at the factory. The purse strings may shrink or stretch after use and require adjustment.

Whenever new purse strings are installed, adjustments must be made. When installing a new set of purse strings, orientate the valve correctly and always make sure to stagger the strings from side to side. See *Section 8: Repairs* for complete instructions on how to replace purse strings.



When initially tying up the purse strings, note that more tension should be on the outside string with progressively less tension towards the middle. If the tension is too great on the middle string, the valve action will be sluggish when the valve is retracting.

Section 4: Making Adjustments

To adjust a single string:

1. Simply adjust the tension of the string to equal that of adjacent strings. Repeat the knot shown three times for each purse string.

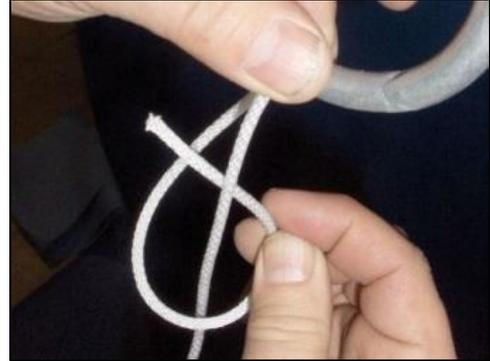

To adjust all the strings:

1. Stand the bucket vertically.
2. With the valve bottom flat on the floor, pull the bucket shell into a round shape by deploying the IDS.
3. Run a rope from an overhead support to the ring on the top of the valve.
4. Proceed to adjust the strings.



Once the strings are adjusted, fill the Bambi Bucket with water, just below the top of the valve. Check to see if both lips of the valve are matched right across the top. Sometimes, one lip will 'track' slightly above or below the other.

Usually, one or two specific purse strings will cause this improper tracking. To correct:

1. Grasp the purse strings at the centre of the lower side.
2. Pull the strings several times to bring the lip into alignment.
3. Re-tie the purse strings so that the string is just snug. Do not over-tension the string. Over tensioning will result in misalignment at another position on the valve.



Section 5: Packing and Storage

Packing the Bucket

1. Collapse the IDS by pushing the hub into the bucket.



2. Grab the control head and pull the suspension lines taut. Tape the lines together in two bunches.



3. Insert the operations manual into the storage bag.



4. Insert the control head into the storage bag.



Section 5: Packing and Storage

5. Gather the suspension lines into a coil and stow inside the bucket. Place the control head outside of the bucket to prevent the possibility of the lines tangling.



6. Avoid any sharp folds along the base of the shell as this protects the shell from delamination which can occur if the Bambi Bucket is stored for a long period of time.



7. Place the control head bag on top of the collapsed bucket.



8. Roll the bucket into a bundle and wrap with straps supplied.



Section 5: Packing and Storage

9. Take the carrying bag and drape it over the bucket.



10. Roll the bucket over and close the bag.



Storing the Bucket

Prior to storage, wash the bucket with fresh water and dry completely to prevent the growth of mildew and the corrosion of aluminium and steel parts. If the bucket is used in salt water, or with firefighting foam or retardant, take extra care when cleaning to remove all residue. Salt, foam and retardant can accelerate corrosion and degradation of materials if not removed. If necessary, a mild detergent can be applied to remove stubborn build-up. Store the bucket indoors and out of direct sunlight.

The Bambi Bucket carrying bag makes a suitable shipping container when shipping via airfreight. Because of the compactness of the Bambi Bucket, many operators carry it aboard the helicopter at all times during the fire season. This allows for rapid deployment when required.

THIS PAGE INTENTIONALLY LEFT BLANK

Section 6: Troubleshooting Guide

Valve Troubleshooting

Leaking Dump Valve

1. Check that the bolts securing the valve and gasket to the shell are equally fastened. There should be approximately 2 threads exposed past each nut. If necessary, butyl rubber sealant can be used to seal stubborn leaks between the shell and the gasket.



2. Work out any creases in the foam lips of the dump valve. If there is significant deterioration in the material, it may be necessary to replace the dump valve.

3. Check that the purse strings are tied to the ring at the location marked on the string, and that they are threaded through the valve grommets in an alternating pattern.

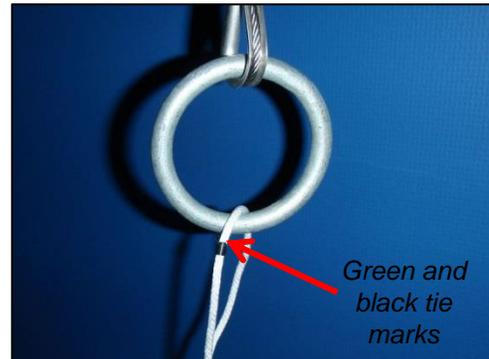

Section 6: Troubleshooting Guide

4. Adjust the chain on the tripline so that the valve has approximately 2" (50 mm) of udder hanging below the shell when the bucket is full of water. Too much or too little udder will not allow the valve to seal optimally and may lead to other issues.



Control Head Troubleshooting

Head Doesn't Release Dump Valve

1. With the cover plate removed, activate the solenoid. A click should be heard when the circuit is closed.
2. Check the wires on the solenoid for shorting.
3. Check the terminal block for loose wires.

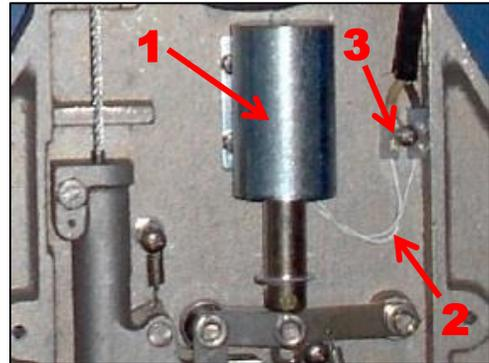

4. Check the resistance of the solenoid using an ohmmeter. It should measure approximately 5.7 ohms resistance. A higher resistance may indicate a poor connection or a burned out solenoid. A lower resistance may indicate a shorted solenoid coil.



5. Check for jamming of the linkage. The tail of the catch may be caught on the bearing. Activate solenoid to release.
6. Check the catch for burrs at the bearing or the point. The point can be worn by the passage of the trip line bullet. Remove burrs with a fine file.

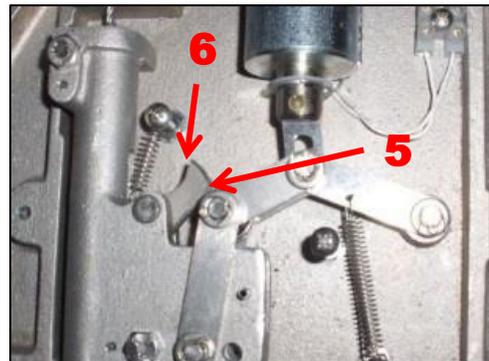

Section 6: Troubleshooting Guide

7. Check that the spring link is resting on the body of the stop bolt and not on the head of the bolt, with the control head sitting vertically.
8. Check for rifling in the trip block and deformation on the top of the bullet.

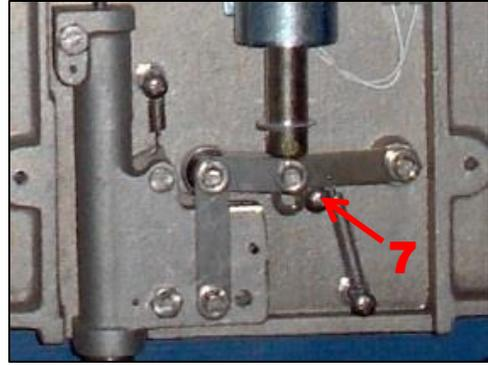

Head Releases Dump Valve Prematurely

1. Tighten trip block bolts.
2. Check that links are below the centreline of the clevis pins. Adjust links as required.
3. Check that the links do not catch on the bolt head.

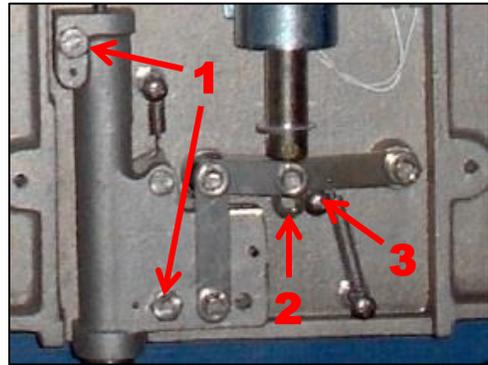

4. Check the catch point for wear at the bullet. Replace catch if necessary.

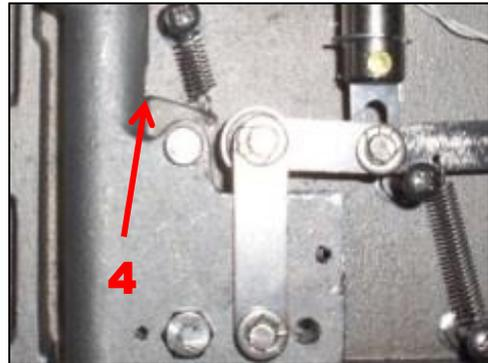

Section 6: Troubleshooting Guide

Tripline Jams on Returning

1. Pull the tripline completely out. Check that the swaged sleeves at the end of the tripline are not fouling the cast guide lugs on the head and cover.
2. Round the end of the swage sleeves with a file.
3. If necessary the lower set of cast lugs (closest to the trip block) on the head act as a safety keeper to prevent a tripline broken at the top end from causing a tail rotor strike. The swage blocks should not pass between them.

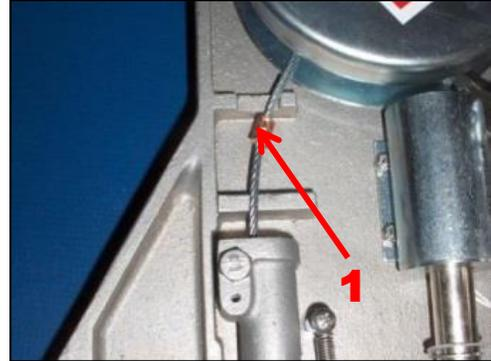

Tripline Doesn't Return

1. Check for a broken spring in the reel. A broken spring is indicated if the tension on the reel doesn't increase as the reel is wound, or if the tension increases in jerks or the spring seems to "slip" inside the reel. See *Section 8: Repairs* for **Error! Reference source not found.**

Section 7: Repair Assessment Guide

Overview of Repair Categories

This section is intended to provide the user with information that will allow for the quick repair assessment evaluation of the Bambi Bucket. The repair assessment process is almost identical for all sizes of the Bambi Buckets, with some exceptions for minor bucket design variations between the models. This section also offers specific guidelines that sort the component defects into one of three categories: Safety, Operational, and Monitor. Use the guideline definitions to determine how urgently a repair should be carried out.

Category 1: Safety

All defects in this category must be repaired immediately before further operation of the Bambi Bucket occurs. Ignoring defects in this category could result in personal injury or damage to equipment. These defects can compromise the following functions of the Bambi Bucket: structural integrity, flight stability, water release and flight safety.

Category 2: Operational

All defects in this category should be repaired before the next operational day or approximately eight hours of flight time. The defects do not compromise the safety of the bucket but may lead to Category 1 defects, if not addressed within a short time frame.

Category 3: Monitor

Many defects such as wear, abrasion and minor impact damage do not need urgent attention. Defects of this nature should be monitored daily and repaired before they progress to a Category 2 defect.

NOTICE

It is impossible to provide a recommended service time frame as some buckets are used often while others are used only rarely. In addition, buckets are shifted between operators, making it difficult to track usage. If you are unsure of your bucket's status, check with any Bambi Bucket Service Centre, in your area, for more information and assistance.

Section 7: Repair Assessment Guide

Control Head Repair Criteria

Category 1: Safety

Cease operations and repair immediately.

- Any visible crack or break on the base plate.
- Visibly bent shackles or suspension line bolts.
- Missing, broken or loose valve release mechanism parts.
- Broken or missing safety wire on shackle pins.
- Broken or exposed electrical conductors.
- Broken or missing breakaway plug.
- Broken or cracked shackle yoke.

Category 2: Operational

Repair before next day's operation or eight hours flight time.

- Missing control head cover hardware.
- Cracked or damaged control head cover.

Category 3: Monitor

Monitor and/or repair if condition deteriorates.

- General wear and visual condition of components including electrical connections and wire.
- Optimal function of valve release mechanism (check daily).

Section 7: Repair Assessment Guide

Cables Repair Criteria

Category 1: Safety

Cease operations and repair immediately.

- One or more broken suspension cables or end fittings.
- Broken deployment cable.

Category 2: Operational

Repair before next day's operation or eight hours flight time.

If three or more individual suspension cables or the deployment cable have the following defects:

- 10 or more randomly distributed broken strands or four adjacent broken strands
- Visible kink(s).
- Separation of the strands due to twisting (known as "bird-caging").
- Evidence of heat damage.
- Abrasion wear comprising of more than 1/3 of the original diameter of the outside individual strands.
- Any visible reduction in outside diameter due to overload.
- Cracked or broken end fittings (some elongation of cable eyes is acceptable).

Category 3: Monitor

Monitor and/or repair if condition deteriorates.

- Wear, broken strands, kinks and twisting in cable that does not exceed the limits defined in Category 2 defects.

Section 7: Repair Assessment Guide

M-Straps/Top Chains Repair Criteria

Category 1: Safety

Cease operations and repair immediately.

- Broken top chains.
- Broken or missing shackles.
- Two or more broken M-straps.

Category 2: Operational

Repair before next day's operation or eight hours flight time.

- M-straps with more than 25% of the fabric strands broken.
- Visibly worn top chains.
- Bent, gouged, worn or cracked shackles and shackle pins.

Category 3: Monitor

Monitor and/or repair if condition deteriorates.

- Damage to an M-strap that does not exceed 25% of the fabric.
- Minor wear, impact marks or corrosion on chains.
- Minor wear, impact marks or corrosion on shackles.

Section 7: Repair Assessment Guide

IDS Repair Criteria

Category 1: Safety

Cease operations and repair immediately.

- Cracks or breaks across the major section of the IDS hub.
- Two or more broken or cracked spoke brackets.
- Two or more broken or missing spokes, clevis pins, shell brackets.
- Three or more bent spokes (bends in excess of 20° = broken).

Category 2: Operational

Repair before next day's operation or eight hours flight time.

- One broken or cracked spoke bracket on IDS hub.
- One broken or missing spoke.
- One broken or missing clevis pin or shell bracket.
- Up to two bent spokes.

Category 3: Monitor

Monitor and/or repair if condition deteriorates.

- Wear on IDS hub.
- Dents, abrasions and wear on spokes.
- Clevis pin and shell bracket wear.

Section 7: Repair Assessment Guide

Bucket Shell Repair Criteria

Category 1: Safety

Cease operations and repair immediately.

- One or more broken top loop knots (M-strap attachment point to the shell).
- Gross punctures through shell that cut or severely damage one or more panel strips.
- Separation of fabric welds longer than 3" (76 mm).
- Punctures or cuts through shell longer than 3" (76 mm).
- Two or more broken bottom webbing loops.

Category 2: Operational

Repair before next day's operation or eight hours flight time.

- Top loop knots that are worn or have damage to more than 25% of the fabric.
- Cuts, punctures or weld separations less than 3" and/or cut through more than 25% of a panel strip.
- Bottom webbing loops with more than 25% damage to fabric strands.
- Broken or missing bottom webbing protective wear strips.
- Five or more broken battens.

Category 3: Monitor

Monitor and/or repair if condition deteriorates.

- Wear, abrasions, and cuts to the bucket shell fabric isolated to one side of the material that do not cut through.
- Wear, abrasions and cuts to the webbing loops, strips and top loop knots that involve less than 25% of the fabric strands on any portion of the affected webbing.
- Wear and abrasions to webbing protective strips.
- Up to 4" (102 mm) of peeled weld on panel strip.
- Up to four broken battens.

Section 7: Repair Assessment Guide

Cinch Strap Repair Criteria

Category 1: Safety

Cease operations and repair immediately.

- Broken or missing cinch strap.
- Field-modified cinch strap.
- Broken or missing cinch strap retaining brackets.
- Broken or missing cinch strap hook or mating ring.

Category 2: Operational

Repair before next day's operation or eight hours flight time.

- Wear or damage to cinch strap involving more than 25% of the fabric strands.
- Missing cinch strap bracket hardware.

Category 3: Monitor

Monitor and/or repair if condition deteriorates.

- Wear or damage to cinch strap, less than 25%.
- Worn or bent brackets.

Section 7: Repair Assessment Guide

Valve Repair Criteria

Category 1: Safety

Cease operations and repair immediately.

- Broken valve restrainer cable.
- Two or more broken purse strings.

Category 2: Operational

Repair before next day's operation or eight hours flight time.

- Up to one broken purse string.
- Wear or damage to the purse strings comprising more than 50% of fibers.
- Cuts or tears on valve material.
- Broken stitching that allows separation of seam(s).
- Wear, abrasion and creases that allow leakage.
- Broken or missing valve bolts.
- Missing or broken purse strings grommets.
- Frayed wires on riser cable.

Category 3: Monitor

Monitor and/or repair if condition deteriorates.

- Wear and abrasion on valve material.
- Wear on purse strings.
- Valve bolt security.

Section 8: Repairs

Control Head Repairs

For proper operation of the control head, avoid the following modifications:

- Do not use another type of bearing as a replacement for the ball bearing.
- Do not use lock wire as a substitute for the swage blocks on the tripline.
- Do not shorten or change the portion of the tripline which attaches to the reel.
- Do not use threaded bolts as a substitute for clevis pins.
- Do not modify the size or angles of the catch, other than as recommended.
- Do not tighten control head suspension bolts over 5 ft·lb (6.5 N·m).

Spring Reel & Tripline Replacement

The following procedure is for replacing a spring reel and tripline. Steps that are particular to the spring reel or tripline replacement are identified. Ignore these steps if that part is not being replaced.

CAUTION

It is recommended to wear protective gloves and eyewear while performing this procedure. Failure to do so may result in injury.

1. (*Tripline*) Take note of which riser cable chain link the tripline is shackled to. Disconnect the tripline from the riser cable chain while leaving the shackle attached to the chain.



Section 8: Repairs

2. Open the control head by removing the screws, p-clip, and cover.



3. Unwrap the tripline from the spring reel drum to release the spring preload. Do this until there is no tension on the tripline.

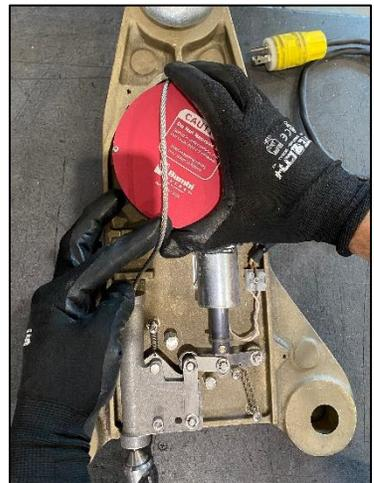

4. Remove the nut from the spring reel arbor located on the back of the control head then pull out the spring reel.



Section 8: Repairs

5. Unwrap the remaining tripline from the spring reel then remove the screw and retainer plate from the back of the spring reel.



6. Pull out the end of the tripline from the cavity then feed it through the large hole to detach it.



7. (*Tripline*) Lift the solenoid plunger and linkage to release the catch, then pull the tripline out from the bottom of the tripblock.

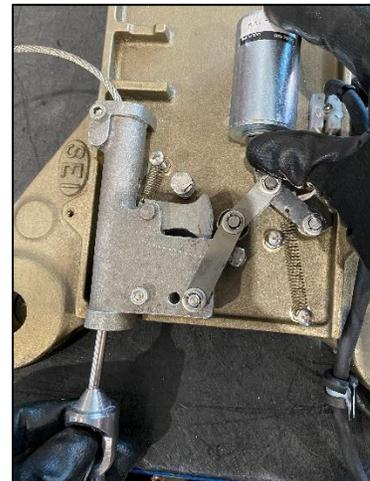

Section 8: Repairs

8. (*Tripline*) Insert the end of the new tripline up and through the bottom of the tripblock.



9. (*Spring Reel*) Swap the malfunctioning spring reel with a working one.

10. Feed the end of the tripline into the spring reel drum and through the large hole on the back.



11. Place the end of the tripline into the cavity and install the retainer plate and screw.



Section 8: Repairs

12. Check that the washer and torque plate are installed onto the spring reel arbor, then insert it into the control head so that the torque plate is seated between the tabs on the casting.



13. Install the nut onto the spring reel arbor while ensuring that the torque plate is still seated properly on the arbor.

Tip: If the plate has fallen off the arbor, rotate the spring reel until the arbor aligns with the slot on the plate then press to reseat it. The plate is seated properly if the spring reel develops torque when rotated counterclockwise.

Tighten the nut to 25 - 30 ft-lb.



Now that the spring reel is installed into the control head, follow steps 14 - 17 to preload the spring reel.

14. Wrap the tripline **counterclockwise** onto the drum of the spring reel **9 revolutions** without turning the spring reel (do not tension the spring).



Section 8: Repairs

CAUTION

The following procedure will cause the spring to be in tension and can cause injury if it is released prematurely. Overtensioning the spring may result in failure.

15. Preload the spring reel by turning it **counterclockwise 5 revolutions**. Do this by pulling the tripline from the bottom of the tripblock.



16. Grip the spring reel and hold it in place, then wrap the tripline **counterclockwise** onto the drum of the spring reel **5 revolutions**.

Tip: Hold the spring reel with your left hand (thumb and palm) in the 9 o'clock position and grip the control head with your fingers. Use your right hand to wrap the tripline around the spring reel to your left thumb. Hold the spring reel in place with your right hand in the 3 o'clock position then release your left hand to let the tripline pass.

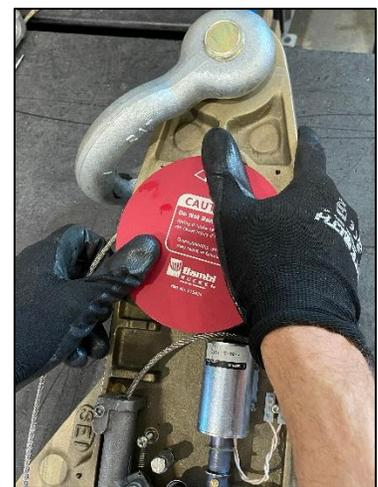

Section 8: Repairs

17. Slowly and carefully release the spring reel and allow it to pull the remaining tripline onto the drum and the bullet assembly into the tripblock.

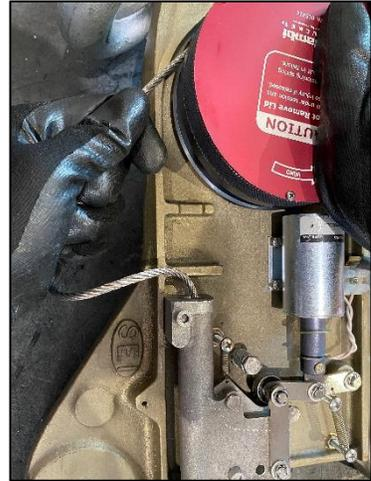

18. Install the cover, p-clip, and screws.



19. (*Tripline*) Connect the tripline to the shackle on the riser cable chain.



Section 8: Repairs

Rigging Repairs

Suspension Line Replacement

A suspension line should be replaced whenever it displays noticeable kinking or fraying. Factory replacement lines come pre-swaged with connection links to make replacing quick and easy.

To remove the connecting link between the suspension line and the M-strap, follow these procedures:

1. Locate a metal bar with a 5/16" hole (or drill a 5/16" hole into any metal bar). If you are unable to locate a metal bar, a wooden block will work, however, make sure to drill the hole into the end grain.



2. Place the connecting link with the pin located over the hole and using a 3/16" punch, drive pin through the centre holding sleeve.



3. After the pin is free, remove the old suspension line. Place the new line in the connecting link by inserting the pin into one side of the connecting link. Using a hammer, drive the pin in until it is flush with both sides of the connecting link.



Section 8: Repairs

M-Strap Replacement

Replace M-straps if they become noticeably worn. M-straps may be repaired, if frayed, by melting the fray with a lighter to stop the fray from spreading. The length of the M-strap is critical to the Bambi Bucket functioning correctly. It is recommended that you replace worn straps with factory-supplied equipment.

There are two types of straps. The short straps are vertical and are a continuous loop. The long straps are diagonal and have a loop on each end.

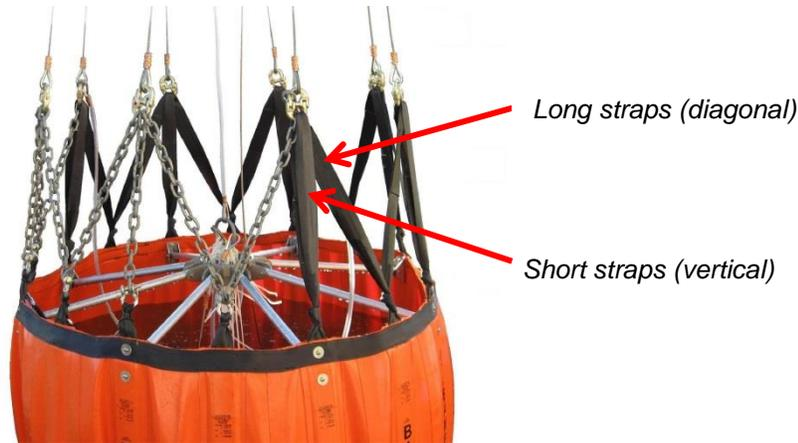

Replace one set of straps at a time to avoid confusion.

1. Cut off the old strap from the shackle.
2. Using needle nose pliers, insert the tip under the top webbing layer.
3. Fully insert the pliers at the far left hand side of the top layer.



Section 8: Repairs

4. Holding the pliers tight, turn your hand clockwise. Repeat the operation until the knot is loose enough to remove the strap.



5. Complete step 'a' or 'b' depending on whether the strap is short or long.
 - a. For short straps, grasp the strap and rotate until the joint is centred.



- b. For long straps, locate the centre of the strap and fold back to form a loop.



6. Pass the loop of the strap through the loop on the top of the bucket.



Section 8: Repairs

7. Twist the strap loop eye 180 degrees.



8. Rotate the eye to the opposite side.



9. Pull strap end through the eye.



10. Pull strap tight.



Section 8: Repairs

11. The M strap set should now look like this. The suspension line attaches to the top of each M-strap set.



IDS Replacement

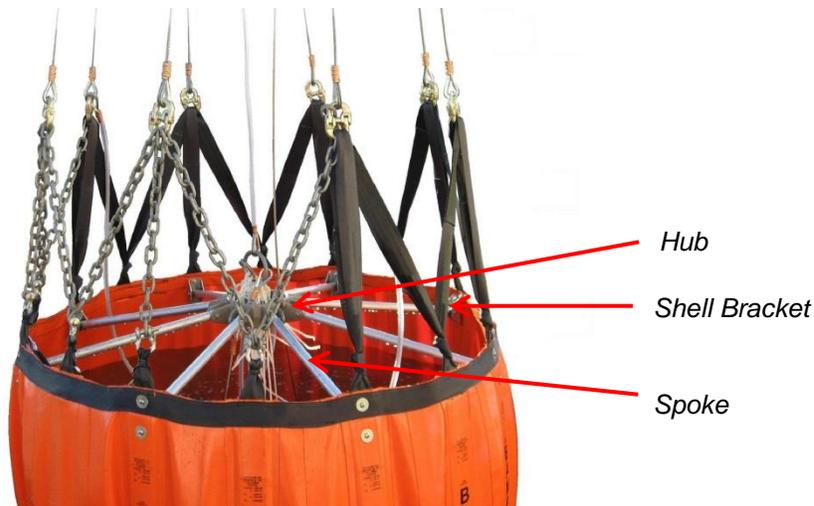

The IDS can be replaced either as a complete kit or as individual pieces, as required. See *Section 9: Specifications and Parts* for detailed parts drawings. Follow the procedure below to replace the entire assembly:

1. Disconnect the tripline from the valve and remove through the IDS hub.
2. Disconnect the IDS restrainer cables from the cable restrainer brackets in the shell.
3. Disconnect the IDS deployment cable from the head.
4. Remove the pins which secure the outer ends of the spokes to the shell brackets. Remove the IDS assembly from the bucket.
5. Inspect the shell brackets and replace as necessary.
6. With the ballast oriented at the 6 o'clock position, rotate the new IDS assembly so that the deployment cable faces upward at the 3 o'clock position.
7. Attach the two spokes at either side of the 12 o'clock position using the stainless steel clevis pins. Working around the bucket perimeter, attach the rest of the spokes.

Section 8: Repairs

8. Once the IDS is fully installed, test for fit. You should be able to pull the hub past the midpoint position with a slight effort. If the IDS is either too loose or too tight, it will require adjustment. If the IDS is too tight, adjust as follows:
 - a. Cut off one spoke just above the existing hole on one end only. Redrill a new hole centred the same distance from the new end of the spoke as the other spokes. Replace the spoke and check for fit.
 - b. If the IDS is still too tight remove another spoke directly across from the first modified spoke and repeat the previous step.
9. Pass the tripline through the hub and re-attach to the dump valve
10. Attach the IDS deployment cable to the control head small adjustment chain.
11. Attach the IDS restrainer cables.

Bottom Loop Repairs

If the bottom loops, which hold the chain, become worn, the frays can be melted with a lighter to prevent them from spreading. If the bottom loops require replacement, they should receive an overlay of heavy duty wear resistant webbing.

Section 8: Repairs

Valve Repair and Replacement

Dump Valve Replacement (Models 2024-3542)

Replacement dump valve assemblies come complete with new purse strings, bolts, nuts, washers and gasket.

To replace a valve:

1. Remove the old valve, gasket and all butyl tape.
2. Stand the bucket up with the valve hole on the bottom.
3. Place the new gasket in with the holes aligned to the grommets on the shell.



4. Place the stainless washers and then the rubber washers onto the bolts. Insert the bolts up from outside of shell.
5. Place the new valve into the bucket where the vertical seam on the valve is in-line with either of the IDS restrainer cable brackets on the shell.
6. Install the remaining stainless washers and nuts onto the bolts and fasten them until two threads on the bolts show. Do not over-tighten.

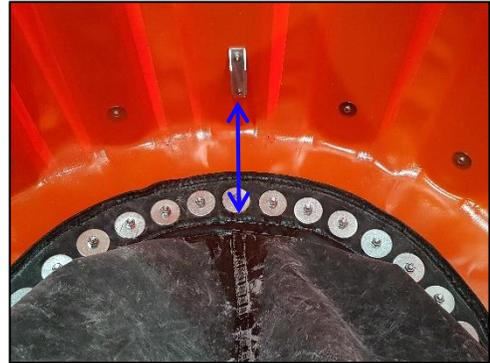

Section 8: Repairs

Dump Valve Replacement (Model 4453)

Replacement dump valve assemblies come complete with new purse strings, bolts, nuts, washers and butyl rubber sealant.

To replace a valve:

1. Remove the old valve and all butyl tape.
2. Stand the bucket up with the valve hole on the bottom.
3. Place a ring of butyl tape around the outside of the grommets on the shell.



4. Place the stainless washers and then the rubber washers onto the bolts. Insert the bolts up from outside of shell.
5. Place the new valve into the bucket where the vertical seam on the valve is in-line with either of the IDS restrainer cable brackets on the shell.
6. Install the remaining stainless washers and nuts onto the bolts and fasten them until two threads on the bolts show. Do not over-tighten.

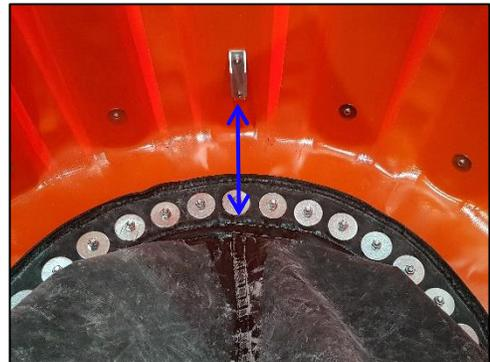

Section 8: Repairs

Purse String Replacement

Depending on the bucket model, the valve may have 12 or 17 purse strings. The strings have coloured markings that indicate the location of the strings on the valve and where to tie the string on the metal ring. For the multi coloured string sets, the green strings are placed at the outer ends, the red strings next and the black strings in the middle. The sequence of strings should be GRBBBBBBBBRG.

MODEL	QTY	MARKS
BB2024	12	2 x GREEN 2 x RED 8 x BLACK
BB2024S		
BB2024L		
BB2226		
BB2732		
BB2732B3		
BB2732S		
BB3542		
BB420B		
BB4453	17	17 x BLACK

Braided nylon for new purse strings can be purchased locally. Make sure to use nylon which is self-lubricating in water. After cutting the new string, melt the ends with a lighter to prevent fraying. Tie a figure eight knot on one end of the new string large enough to prevent passage of the string through the washer.

To replace all purse strings:

1. For multi-coloured string sets, find a purse string with a green mark. For single coloured string sets, use a string with a black mark. Install this string through one of the end grommets and through its mating grommet on the other side of the valve.
2. Take the free end of the string with the mark and loop it through the metal ring. Centre the mark on the metal ring.



Section 8: Repairs

3. Tie the purse string to the metal ring at the mark with a round turn and three half hitches.



4. For multicoloured string sets, find a purse string with a red mark. For single coloured string sets, use another string with a black mark. Starting from the opposite side of the valve as the first string, install this string through the next set of grommets.



5. Tie the string to the ring on the inside of the previous string.

6. Find a purse string with a black mark. Starting from the opposite side of the valve as the previous string, install this string through the next set of grommets.

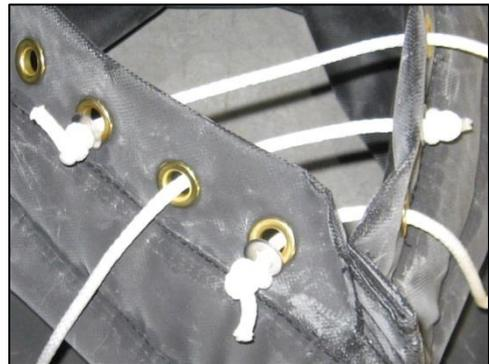

7. Tie the string to the ring on the inside of the previous string.

8. Repeat the process with the remaining strings alternating from one side of the valve to the other. For multi-coloured string sets, the second to last string should have a red mark and the last string should have a green mark.



Further details on purse string adjustments are given in *Adjusting Purse Strings* in this manual.

Section 8: Repairs

Shell Repairs

Please read these instructions carefully and follow them exactly to obtain a good repair. Failure to follow these instructions or poor repair workmanship can lead to failed repairs and/or more damage to the bucket.

Temporary Repairs with Sealing Clamps

Repair clamps are used for an immediate repair to prevent the loss of liquid through large rips or holes. For example, if a vehicle accidentally backed into a bucket and caused a 3" (76 mm) long rip in the bucket, a repair clamp could be inserted to stop the loss of liquid. Repair clamps are only used for temporary repairs. The damage should be permanently repaired with a patch when the bucket can be set aside for 24 hours.

1. Select the largest clamp that will just slip through the hole in the item. The size of cut or hole will determine the size of the sealing clamp to use.
 - For a cut or hole up to 2" (5 cm), use a 3" (7.6 cm) clamp (supplied).
 - For a cut or hole up to 4" (10 cm), use a 5" (12.7 cm) clamp (supplied).
 - For a cut or hole up to 6" (15 cm), use a 7.5" (19 cm) clamp (special order).
2. Keeping hold of the string, slip one half of the repair clamp through the hole as indicated.



3. Pull the bolt up through the hole. Turn it until the clamp lines up with the hole.



Section 8: Repairs

4. Place the top of the clamp over the bolt, then install and tighten the wing nut.



NOTICE

Leaving the clamp's string on makes it easier to remove the repair clamp when placing a permanent patch on the bucket.

NOTICE

Tightening the nut with tools may break the bolt away from the lower clamp. Over tightening can also deform the clamp and cause leaks.

Temporary Repairs Using Glue

Before commencing repairs using glue, the weather should be warm (above 60 °F or 15 °C) and dry. In conditions of high humidity, a proper technique is essential for securing the bond strength desired. The presence of surface moisture can destroy the effectiveness of the cemented bond.

The evaporation of solvent from the adhesive may reduce surface temperature below the dew point resulting in condensation of water vapour on the surface of the adhesive. This is often visible as fogging or a milky white appearance on the surface. The use of a solvent to clean the surface prior to cementing can also reduce temperatures below the dew point.

To overcome the high humidity problem, raise the temperature of the patch area. This can be accomplished with a warm air fan.

WARNING

Glue vapours are highly explosive! Explosive vapours may occur causing fire and/or injury. Keep away from all sparks, flame, lighters or cigarettes.

Solvent and glue are both extremely hazardous. Use solvent and glue under well ventilated conditions only.

Use an approved respirator mask to avoid breathing fumes.

When using a warm air fan, either use one which is rated EXPLOSION PROOF or make sure that there is a steady flow of air past the work area to remove fumes as they are generated.

Section 8: Repairs

NOTICE

Try a test repair before attempting to repair the bucket. This will verify your technique without risking damage to the bucket. It is much harder to fix a repair once a failed attempt has been made as the hardened glue is difficult to remove.

Damage to the outer fabric coating, or pinholes which are not leaking, can be repaired with glue only. To perform this type of repair, follow these steps:

1. Fill the weight bag with water prior to beginning repairs.
2. Clean the area to be repaired with an abrasive pad dampened with solvent. Remove all traces of masking tape, if previously used. If possible, place a piece of masking tape on the back side of the item being repaired.



3. Paint the damaged area with glue. Use a thick coat of glue, overlapping the edges of the repair by 1" (25 mm). Be sure that the edges are well coated. A damaged coating should be given two coats of glue. Apply the second coat within four hours of the first coat.



Damage to the base fabric must be repaired with a patch. To perform this type of repair, follow these steps:

1. If there is dampness around the area to be patched, then dry the area with a hot air fan or heat gun. Any loose coating should be cut back with scissors. Support the damaged area on a flat, solid platform. This platform should be strong enough to support the fabric (flat) and allow the patch to be rolled once it is in place.



Section 8: Repairs

2. Scrub the damaged area with an abrasive pad dampened with solvent (isopropyl rubbing alcohol is recommended). Scrub vigorously to remove the cured surface. The area should be clean and dry with a dull matte finish.



3. Wipe with a rag, dampened with solvent, to remove any residue from cleaning. Check to see if the area is totally clean and all coated surfaces and edges are dull. If not, repeat the cleaning. This is critical for a good glue bond.

CAUTION

Solvent will damage the fabric if too much is used or if the fabric is left exposed to solvent residue.

4. Cut a patch at least 2" (50 mm) larger in every direction from the damaged area. A round patch is recommended but, if a rectangular patch covers the damage better, then round all corners. Clean the patch by scrubbing with a pad dampened with solvent. Rub vigorously to remove the gloss from the fabric. Clean **both sides of the patch**, as it is easy to get the patch turned over during installation. The colour of the patch will vary depending on the product repair kit.



5. Apply glue to the patch and damaged area. Wait 30 minutes (at 75 °F or 22 °C) for some of the solvent to evaporate from the glue. The glue should become thicker but still be quite wet. If it has been allowed to dry too long, give both sides another thin coat. If the glue has dried too long, it will be difficult to avoid entrapping air bubbles in the bonded joint.

6. Place the centre of the patch down first, and then roll it out towards the edges with the roller. This expels trapped air. Once the patch is rolled down, do not let it lift up. This will prevent air from getting under the patch which causes a weak bond.



Section 8: Repairs

7. Place a plastic cover sheet over the patch followed by a weight bag for 12 hours at room temperature. Remove the weight bag and leave to dry for 24 hours.

8. If the patch will be subjected to abrasion after 24 hours, paint over the patch with glue. Painting the patch also provides protection from ultra violet light and weather. Allow the bond to harden for 24 hours at room temperature before using the item.



NOTICE

Allow repair to harden for 24 hours at room temperature before using the item.

Repairs will likely fail if:

- The area to be repaired is not perfectly clean and scrubbed to a matte finish before applying the patch.
- Repairs are attempted during wet or cold weather.
- The glue and patch are not properly placed, creating air bubbles between the glue and the patch.
- The patch is not weighed down for 24 hours.
- The bucket is used before the glue has set.

NOTICE

Aquaseal® urethane adhesive is designed for use on fabrics like the Bambi Bucket shell. The shelf life of this adhesive is about one year. Fresh adhesive can be obtained directly from SEI Industries Ltd.

Section 8: Repairs

Hot Air Gun Patching

Hot air gun patching is the preferred method because it provides the most durable, permanent repair possible.

Tools and materials required:

- Patches
- Plastic hand-held roller
- Hot air gun with wide surface nozzle
- Isopropyl alcohol
- Scissors

WARNING

It is extremely dangerous to use a hot air gun in the presence of flammable fumes such as gasoline or paint thinner. There is a high risk of explosion and/or burns.

CAUTION

Injury, especially to hands and fingers, can occur when using a hot air gun. Most welding will occur at temperatures of 800-1000 °F. Wear gloves to protect skin from overheating, burning and blistering.

The procedure for hot air patching is as follows:

1. In a well-ventilated location, clean the area to be repaired as well as one side of the patch with an abrasive pad. Wipe down the repair area and patch with isopropyl alcohol.
2. Mount a wide surface air nozzle on the hot air gun so as to direct the heat flow in a large pattern. Turn the power on, adjust the temperature in the low range first and let the hot air gun warm up. Increase the temperature as required during the operation.



CAUTION

Overheating can occur quickly and can damage the product. It's recommended that you test, using the supplied fabric samples, to determine the correct temperature to be used and the duration of heat to be applied.

Section 8: Repairs

3. Starting from the centre of the patch (held down by the roller), concentrate the heat flow equally to patch and fabric. Apply a light pressure with the roller when the fabric starts melting. This can be seen as small bubbles.
4. Roll the patch down to fuse it to the fabric, moving roller and gun simultaneously. Repeat on the unfused portion of the patch. Let the repaired area cool down. Attempt to peel off at the edges with your fingers. If there is even a slight peel, repeat the operation locally. Otherwise, the repair is finished.



Shell Repair Kits

Repair kits contain some of the tools needed to perform repairs on Bambi Bucket shells. Urethane adhesive is **not included** in this kit. Urethane adhesive can be purchased separately from SEI Industries Ltd.

Kit Contents:

- Fabric Repair Manual
- Weight Bag
- Abrasive Pads
- Seam Roller
- Scissors
- Small Clamp
- Patches
- Zip-lock Bags
- Tool Bag



Section 9: Specifications and Parts

Capacity and Weight Specifications

Capacities and weights are accurate to within 5%. Specifications are subject to change.

CAUTION

The selection of a Bambi Bucket model for a specific aircraft is dependent on many factors including aircraft weight, fuel weight, operation elevation and atmospheric conditions.

The helicopter operator must select a bucket model which is appropriate for their specific situation.

The operator must also ensure that the bucket selected does not pose a tail rotor strike hazard.

Bambi Bucket

Model	Capacity			Empty Weight		Gross Weight	
	IMP Gal	US Gal	Liters	lb	kg	lb	kg
BB2024	200	240	910	130	59	2130	970
BB2024S	200	240	910	127	58	2130	960
BB2024L	200	240	910	132	60	2130	970
BB2226	220	260	1000	128	58	2330	1060
BB2732	270	320	1230	137	62	2840	1290
BB2732B3	270	320	1230	134	61	2830	1290
BB2732S	270	320	1230	133	60	2830	1280
BB3542	350	420	1590	145	66	3650	1650
BB420B	350	420	1590	143	65	3640	1650
BB4453	440	530	2000	180	80	4580	2080

Bambi Bucket with PowerFill Snorkel

Model	Capacity			Empty Weight		Gross Weight	
	IMP Gal	US Gal	Liters	lb	kg	lb	kg
BB2024	200	240	910	176	80	2180	990
BB2024S	200	240	910	174	79	2180	990
BB2024L	200	240	910	177	80	2180	990
BB2226	220	260	1000	174	79	2380	1080
BB2732	270	320	1230	184	84	2890	1310
BB2732B3	270	320	1230	179	81	2880	1310
BB2732S	270	320	1230	179	81	2880	1310
BB3542	350	420	1590	191	87	3690	1680
BB420B	350	420	1590	191	87	3690	1680
BB4453	440	530	2000	222	100	4630	2100

Section 8: Repairs

Parts

Control Head

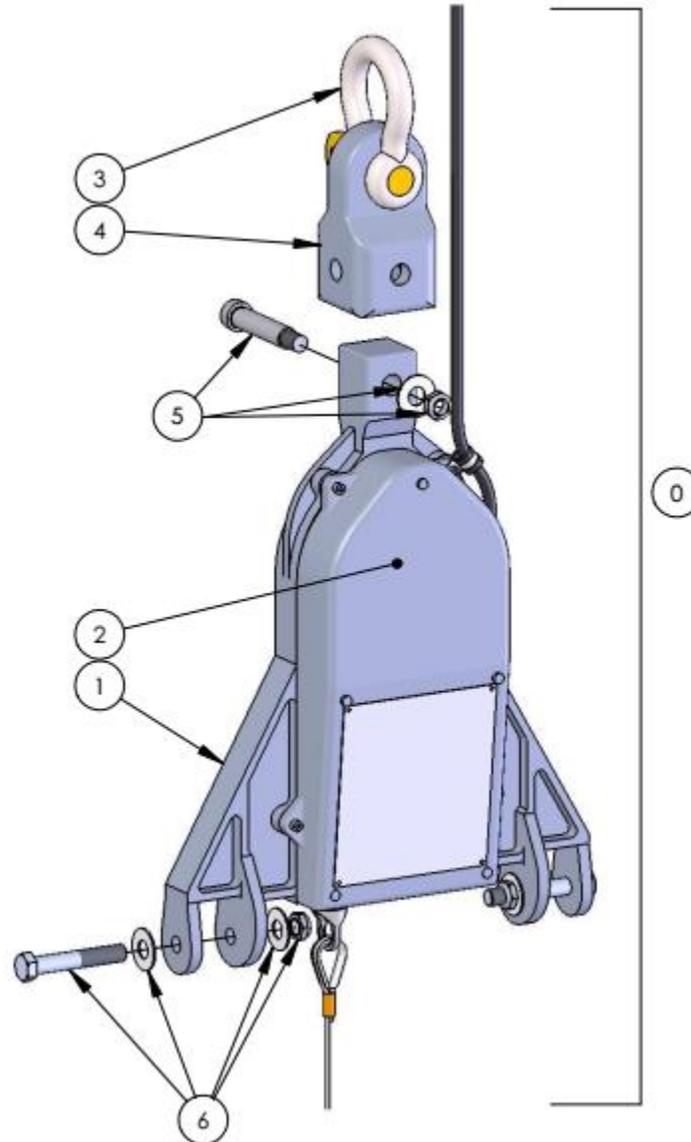

ITEM	MODEL	PART #	DESCRIPTION	QTY
0	ALL	005414	HEAD, CONTROL	1
1	ALL	005248	BASE, HEAD	1
2		005257	COVER, HEAD	1
3		001790	SHACKLE, ANCHOR, SCREW, 3/4", GAL	1
4		005261	YOKE	1
5		014900	HARDWARE, YOKE, KIT	1
6		014901	HARDWARE, SUSPENSION, KIT	2

Section 8: Repairs

Control Head (continued)

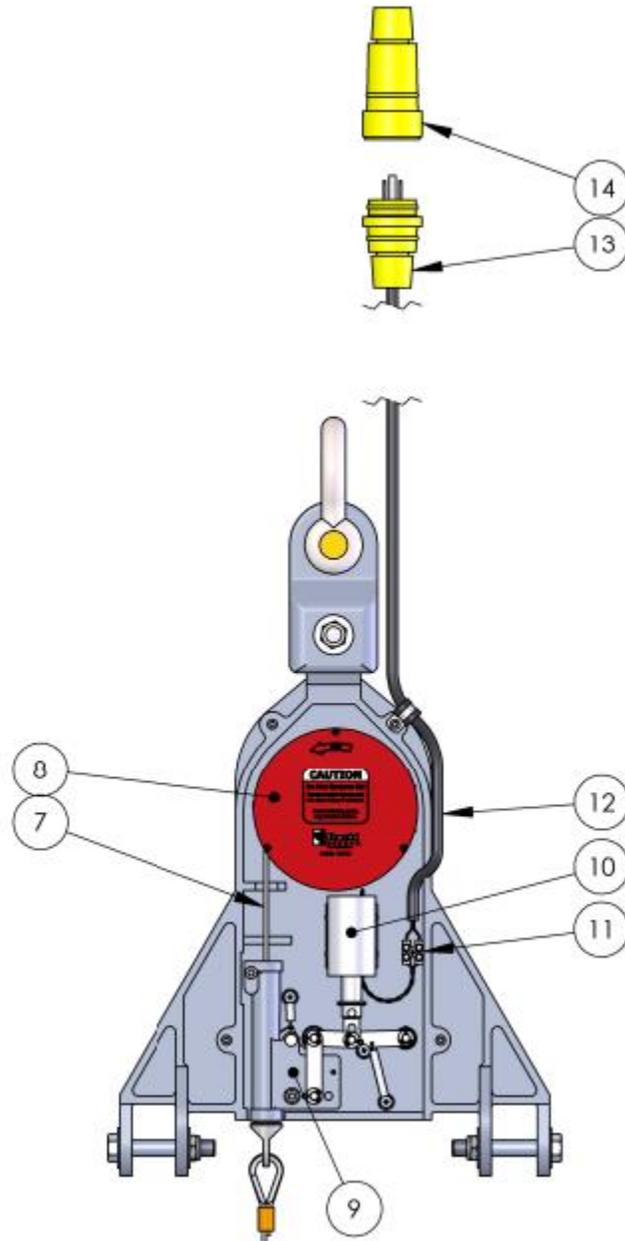

ITEM	MODEL	PART #	DESCRIPTION	QTY
7	ALL	013057	TRIPLINE, FLEX	1
8		015424	REEL, SPRING, HD	1
9		006348	TRIPBLOCK, LINKAGE, KIT	1
10		005220	SOLENOID, W/HARDWARE	1
11		002953	TERMINAL, BLOCK	1
12		005260	WIRE, LEAD, BAMBI	1
13		000982	PLUG, 3 PIN, NEMA 5-15P, IP67	1
14		000990	RECEPTACLE, 3 SCKT, NEMA 5-15R, IP67	1

Section 8: Repairs

Suspension

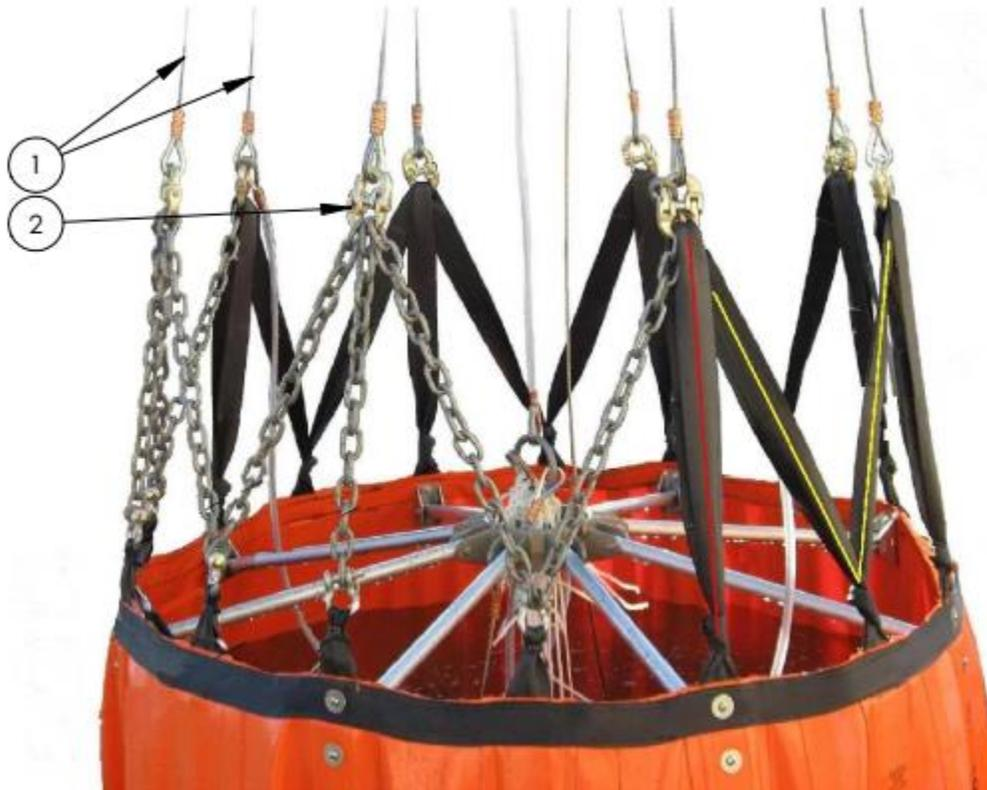

ITEM	MODEL	PART #	DESCRIPTION	QTY
0	BB2024	007678	CABLE, SUSPENSION, SET	1
	BB2024S	007679		
	BB2024L	007680		
	BB2226	007679		
	BB2732B3			
	BB2732	007680		
	BB2732S	008855		
	BB3542	007680		
	BB420B			
	BB4453			
1	BB2024	005547	CABLE, SUSPENSION, PAIR	4
	BB2024S	005548		
	BB2024L	005549		
	BB2226	005548		
	BB2732B3	005548		
	BB2732	005549		
	BB2732S	008854		
	BB3542	005549		
	BB420B			
	BB4453			
2	ALL	004057	LINK, CONNECTOR, SMALL, PLT	8

Section 8: Repairs

Riser, Ring & Restrainer

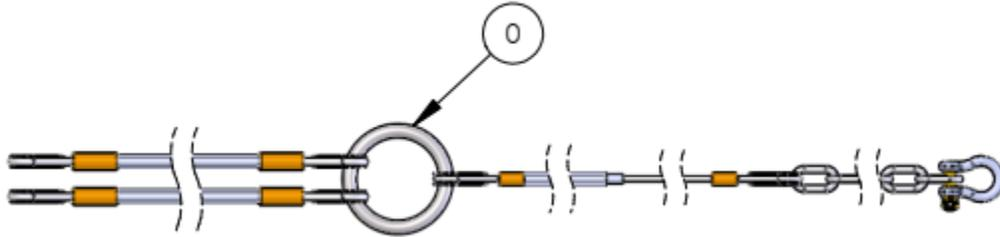

ITEM	MODEL	PART #	DESCRIPTION	QTY
0	BB2024	006110	RISER, RING & RESTRAINER	1
	BB2024S	006114		
	BB2024L	014918		
	BB2226	011756		
	BB2732	006117		
	BB2732B3	009987		
	BB2732S	006121		
	BB3542	006123		
	BB420B			
	BB4453	006630		

Section 8: Repairs

Bucket Shell

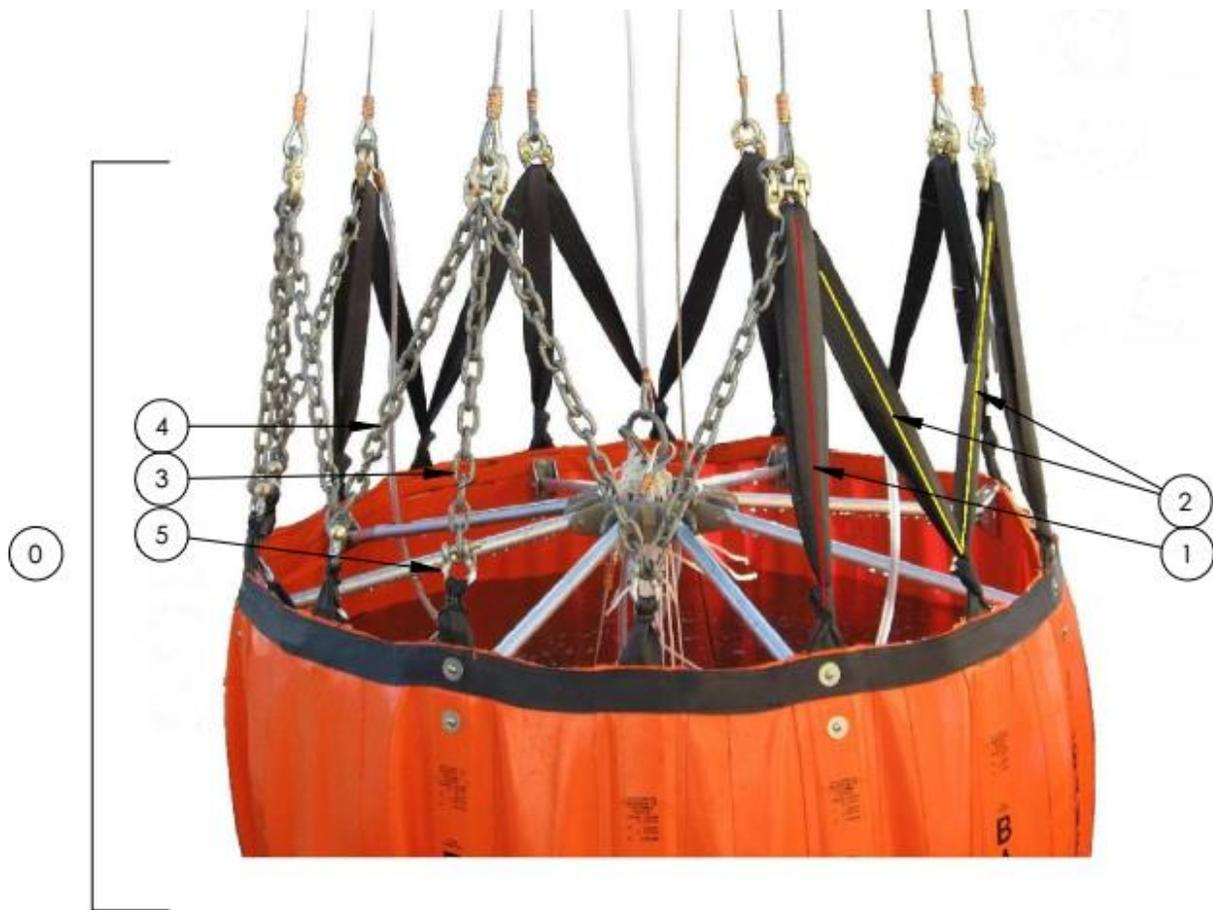

ITEM	MODEL	PART #	DESCRIPTION	QTY
0	BB2024	005782	SHELL, BAMBI, ASSY	1
	BB2024S			
	BB2024L			
	BB2226	005781		
	BB2732	005783		
	BB2732B3			
	BB2732S			
	BB3542	005787		
	BB420B	005788		
	BB4453	005791		

Section 8: Repairs

Bucket Shell (continued)

ITEM	MODEL	PART #	DESCRIPTION	QTY
1	BB2024	005469	STRAP, M, LOOP	6
	BB2024S			
	BB2226			
	BB2732	005471	STRAP, M, LOOP	
	BB2732B3			
	BB2732S			
	BB3542			
	BB420B			
BB4453				
2	BB2024	005470	STRAP, M, STRAIGHT	5
	BB2024S			
	BB2226			
	BB2732	005472	STRAP, M, STRAIGHT	
	BB2732B3			
	BB2732S			
	BB3542			
	BB420B			
BB4453				
3	BB2024	005524	CHAIN, TOP, 14.5"	2
	BB2024S			
	BB2226			
	BB2732	005526	CHAIN, TOP, 18.5"	
	BB2732B3			
	BB2732S			
	BB3542			
	BB420B			
BB4453				
4	BB2024	005525	CHAIN, TOP, 16.25"	6
	BB2024S			
	BB2226			
	BB2732	005527	CHAIN, TOP, 20.25"	
	BB2732B3			
	BB2732S			
	BB3542			
	BB420B			
BB4453				
5	ALL	001789	SHACKLE, ANCHOR, 5/16, SCREW, GALV	5

THIS PAGE INTENTIONALLY LEFT BLANK.

Section 9: Specifications and Parts

Bucket Shell (continued)



ITEM	MODEL	PART #	DESCRIPTION	QTY
6	BB2024	005422	BATTEN, ASSEMBLY	16
	BB2024S			
	BB2024L			
	BB2226			
	BB2732	005424		
	BB2732B3			
	BB2732S			
	BB3542	005425		
	BB420B	005424		
BB4453	005425			
7	BB2024	007638	STRIP, WEAR, ASSY	16
	BB2024S			
	BB2024L			
	BB2226			
	BB2732			
	BB2732B3	008856		
	BB2732S			
	BB3542	007638		
	BB420B			
BB4453				
8	BB2024	007206	CHAIN, BOTTOM, 3/16"x72", ASSY	1
	BB2024S			
	BB2024L			
	BB2226			
	BB2732			
	BB2732B3			
	BB2732S			
	BB3542			
	BB420B	006488		
BB4453				
			CHAIN, BOTTOM, 5/16"x72", ASSY	

Section 9: Specifications and Parts

Bucket Shell (continued)

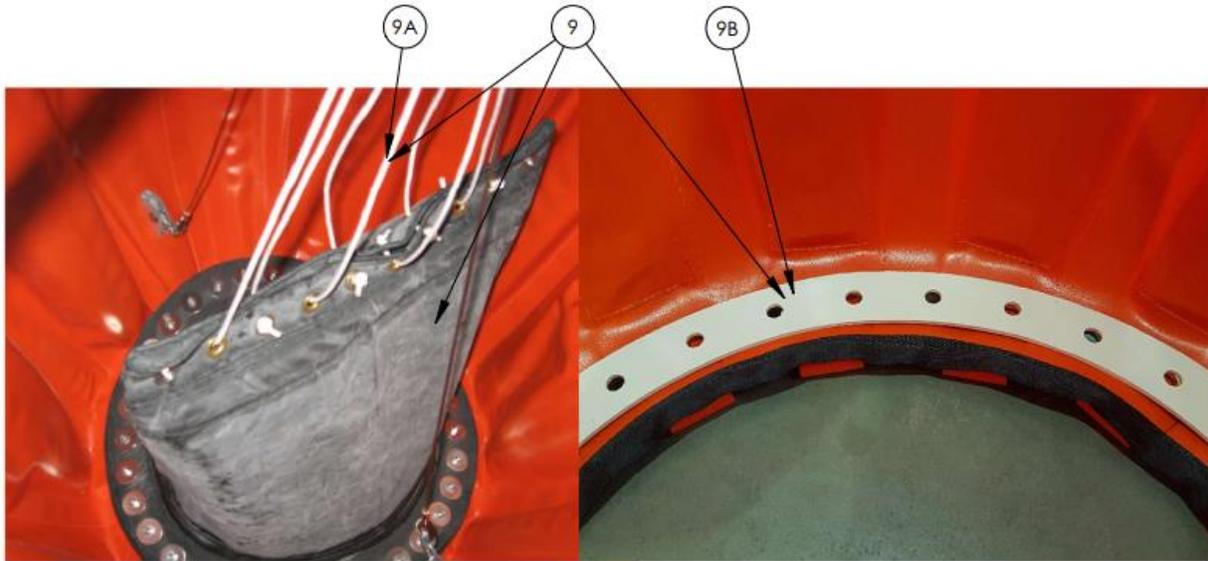

ITEM	MODEL	PART #	DESCRIPTION	QTY
9	BB2024	006091	VALVE, DUMP, ASSY	1
	BB2024S			
	BB2024L			
	BB2226			
	BB2732			
	BB2732B3			
	BB2732S			
	BB3542			
	BB420B			
	BB4453			
9A	BB2024	005616	STRING, PURSE, SET, 2024-3542	1
	BB2024S			
	BB2024L			
	BB2226			
	BB2732			
	BB2732B3			
	BB2732S			
	BB3542			
	BB420B			
	BB4453			

Section 9: Specifications and Parts

Bucket Shell (continued)

ITEM	MODEL	PART #	DESCRIPTION	QTY
9B	BB2024	004357	GASKET, SHELL, MD	1
	BB2024S			
	BB2024L			
	BB2226			
	BB2732			
	BB2732B3			
	BB2732S			
	BB3542			
	BB420B			

Section 9: Specifications and Parts

Bucket Shell (continued)

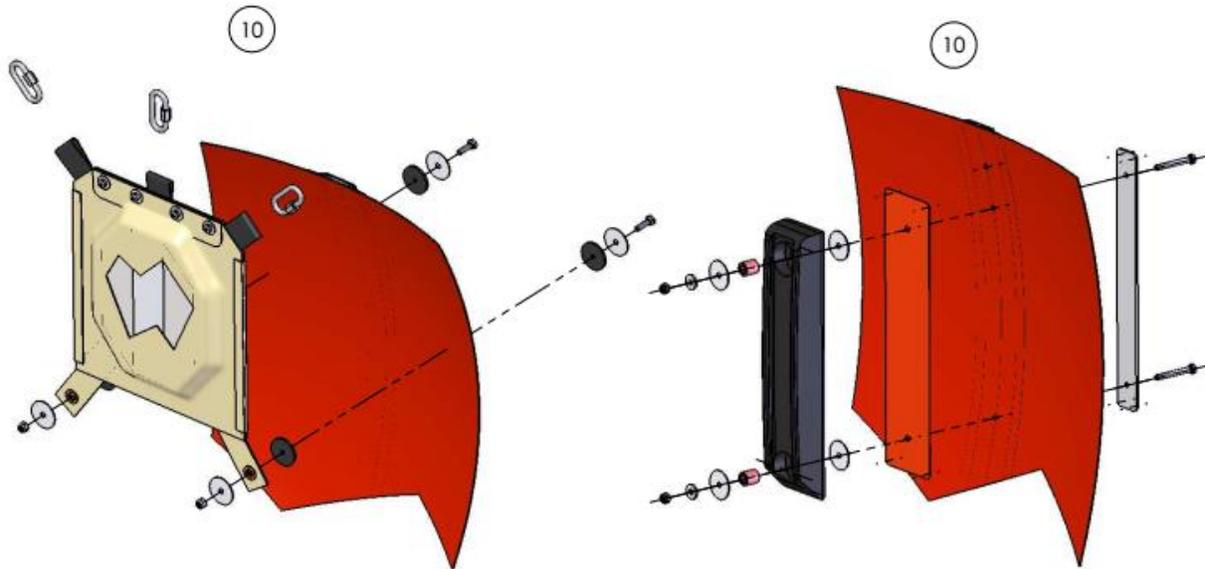

ITEM	MODEL	PART #	DESCRIPTION	QTY
10	BB2024	006186	BALLAST, ASSY	1
	BB2024S			
	BB2024L			
	BB2226			
	BB2732	006187		
	BB2732B3			
	BB2732S			
	BB420B	006188		
	BB3542			
	BB4453	007195		3

Section 9: Specifications and Parts

Bucket Shell (continued)

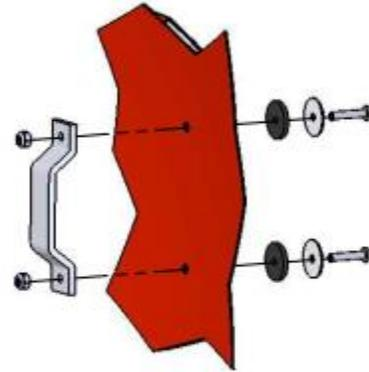
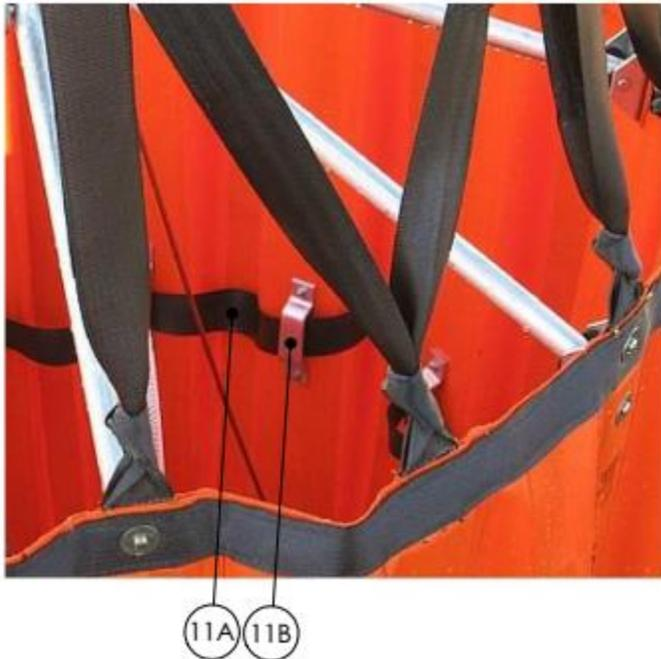

ITEM	MODEL	PART #	DESCRIPTION	QTY
11	BB2024	005507	STRAP, CINCH, ASSY	1
	BB2024S			
	BB2024L			
	BB2226	005508		
	BB2732	005509		
	BB2732B3			
	BB2732S			
	BB3542	005510		
	BB420B			
BB4453	005511			
11A	BB2024	005494	STRAP, CINCH, INTERNAL, 144"	1
	BB2024S			
	BB2024L			
	BB2226	005495	STRAP, CINCH, INTERNAL, 148"	
	BB2732	005496	STRAP, CINCH, INTERNAL, 168"	
	BB2732B3			
	BB2732S			
	BB3542	005498	STRAP, CINCH, INTERNAL, 188"	
	BB420B			
BB4453	005499	STRAP, CINCH, INTERNAL, 193"		
11B	ALL	007200	BRACKET, CINCH, ASSY	16

Section 9: Specifications and Parts

IDS System

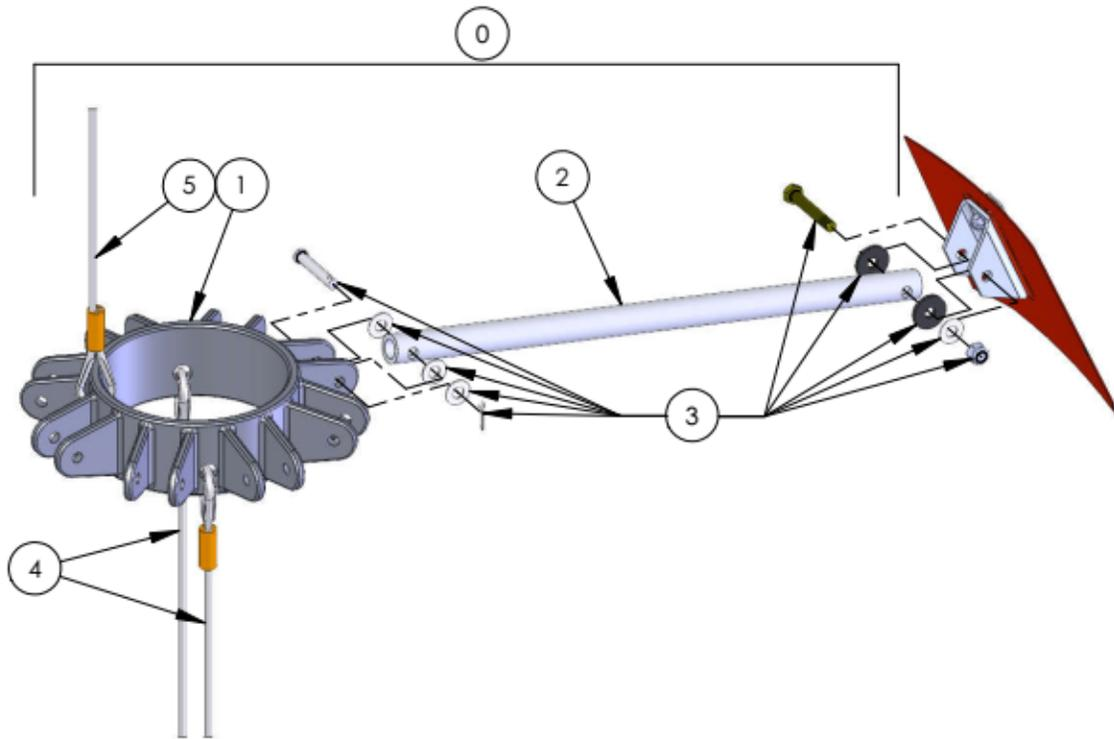

ITEM	MODEL	PART #	DESCRIPTION	QTY
0	BB2024	005398	IDS, ASSY	1
	BB2024S	008826		
	BB2024L	014917		
	BB2226	007695		
	BB2732	005400		
	BB2732B3	010806		
	BB2732S	008827		
	BB3542	005401		
	BB420B			
	BB4453	005402		

Section 9: Specifications and Parts

IDS System (continued)

ITEM	MODEL	PART #	DESCRIPTION	QTY
1	BB2024	005374	HUB/CABLE, ASSY	1
	BB2024S	008833		
	BB2024L	014912		
	BB2226	007224		
	BB2732	005376		
	BB2732B3	009989		
	BB2732S	008834		
	BB3542	005377		
	BB420B			
	BB4453	005456		
2	BB2024	005343	SPOKE, TUBE, 16-3/4"	8
	BB2024S			
	BB2024L			
	BB2226	005344	SPOKE, TUBE, 19-3/8"	
	BB2732	005345	SPOKE, TUBE, 20"	
	BB2732B3			
	BB2732S			
	BB3542	005346	SPOKE, TUBE, 21-5/8"	
	BB420B			
BB4453	007211	SPOKE, SOLID, 24-5/8		
3	ALL	014911	HARDWARE, SPOKE, KIT	8
4	BB2024	010917	CABLE, IDS, RESTRAINER, W/SHACKLE	2
	BB2024S			
	BB2024L			
	BB2226			
	BB2732	010918		
	BB2732B3			
	BB2732S			
	BB3542	010919		
	BB420B			
BB4453	010920			
5	BB2024	010899	CABLE, IDS, DEPLOYMENT, W/SHACKLE	1
	BB2024S	010906		
	BB2024L	010900		
	BB2226	010906		
	BB2732	010900		
	BB2732B3	010909		
	BB2732S	010908		
	BB3542	010900		
	BB420B			
BB4453				

Section 9: Specifications and Parts

Carry Bag

MODEL	PART #	DESCRIPTION
ALL	005599	BAG, CARRY, BAMBI

Spares Kits

MODEL	PART #	DESCRIPTION	CONTENTS
BB2024	006208	SPARES, BAMBI, KIT	SOLENOID, W/HARDWARE (1) REEL, SPRING, HD (1) TRIPLINE, FLEX (1) VALVE, DUMP, ASSY (1)
BB2024S			
BB2024L			
BB2226			
BB2732			
BB2732B3			
BB2732S			
BB3542			
BB4453	006210		

Shell Repair Supplies

MODEL	PART #	DESCRIPTION
ALL	003613	KIT, REPAIR, SHELL
	008905	PATCH, FABRIC, 8"x10"
	014858	PATCH, FABRIC, BULK, 24"x68"
	004502	CLAMP, REPAIR, SMALL
	004503	CLAMP, REPAIR, MEDIUM
	004504	CLAMP, REPAIR, LARGE
	003090	ADHESIVE, AQUASEAL, ¾ OZ
	003091	ADHESIVE, AQUASEAL, 8 OZ

NOTICE

It is the responsibility of the end user to ensure that the importation of glue is allowed in the country of use.

Section 10: Drawings

Pilot Controls

RECOMMENDED COMPONENTS

ITEM	DESCRIPTION	SPECIFICATION
CB1	CIRCUIT BREAKER, 1A	MS22073-1
CB2	CIRCUIT BREAKER, 10A	MS22073-10
K1	RELAY, DPDT, 10A	MS24149
S1	SWITCH, SPST, MOMENTARY	MS24523-28
J1	CONNECTOR, RECEPTACLE	MS3101E-24-11S
P1	CONNECTOR, PLUG	MS3107B-24-11P
J2,J3	CONNECTOR, RECEPTACLE	NEMA 5-15R
P2,P3	CONNECTOR, PLUG	NEMA 5-15P
—	WIRE, #20 AWG	MS22759/16-20
—	WIRE, #16 AWG	MS22759/16-16

LONGLINE DETAILS

LENGTH	GAUGE	TYPE
50 FT	#14 AWG	14/2 SOW
75 FT	#14 AWG	14/2 SOW
100 FT	#14 AWG	14/2 SOW
125 FT	#12 AWG	12/2 SOW
150 FT	#12 AWG	12/2 SOW
200 FT	#12 AWG	12/2 SOW

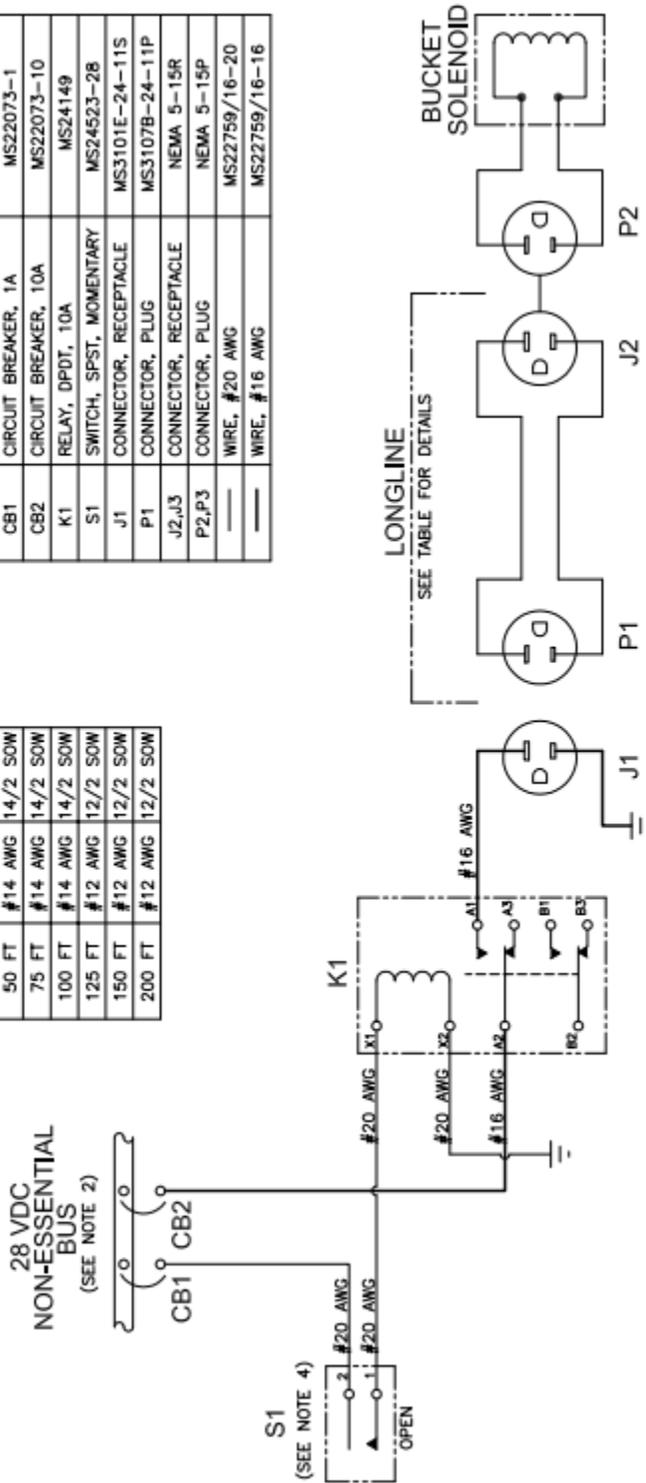

- NOTES:
1. THESE ARE RECOMMENDED INSTALLATION INSTRUCTIONS ONLY. ALL INSTALLATIONS TO BE DONE BY QUALIFIED PERSONNEL IN ACCORDANCE WITH APPLICABLE LOCAL REGULATIONS.
 2. CONNECTION TO AIRCRAFT POWER SUPPLY DONE IN ACCORDANCE WITH LOCAL REGULATIONS. DO NOT CONNECT THE BAMBİ SYSTEM TO ANY AIRCRAFT BUS BAR THAT IS USED FOR EMERGENCY OR ESSENTIAL LOADS. AMMEND THE AIRCRAFT ELECTRICAL LOAD ANALYSIS TO ENSURE THAT THE GENERATOR CAPACITY IS ADEQUATE TO OPERATE THE SYSTEM.
 3. ALL GROUNDS, SOLDERED TERMINALS, AND CRIMPED TERMINALS DONE IN ACCORDANCE WITH AIRCRAFT MANUFACTURERS INSTRUCTIONS.
 4. CONSULT LOCAL CONTRACT REGULATIONS FOR LOCATION OF THE ACTUATION SWITCH.

Section 10: Drawings

Pilot Controls, US InterAgency

RECOMMENDED COMPONENTS

ITEM	DESCRIPTION	SPECIFICATION
CB1	CIRCUIT BREAKER, 1A	MS22073-1
CB2	CIRCUIT BREAKER, 50A	MS24571-50
K1	RELAY, SPST, 50A	MS24166-D1
S1	SWITCH, SPST, MOMENTARY	MS24523-28
J1	CONNECTOR, RECEPTACLE	MS3101E-24-11S
P1	CONNECTOR, PLUG	MS3107B-24-11P
J2	CONNECTOR, RECEPTACLE	NEMA 5-15R
P2	CONNECTOR, PLUG	NEMA 5-15P
—	WIRE, #20 AWG	MS22759/16-20
—	WIRE, #8 AWG	MS22759/16-8

LONGLINE DETAILS

LENGTH	GAUGE	TYPE
50 FT	#14 AWG	14/2 SOW
75 FT	#14 AWG	14/2 SOW
100 FT	#14 AWG	14/2 SOW
125 FT	#12 AWG	12/2 SOW
150 FT	#12 AWG	12/2 SOW
200 FT	#12 AWG	12/2 SOW

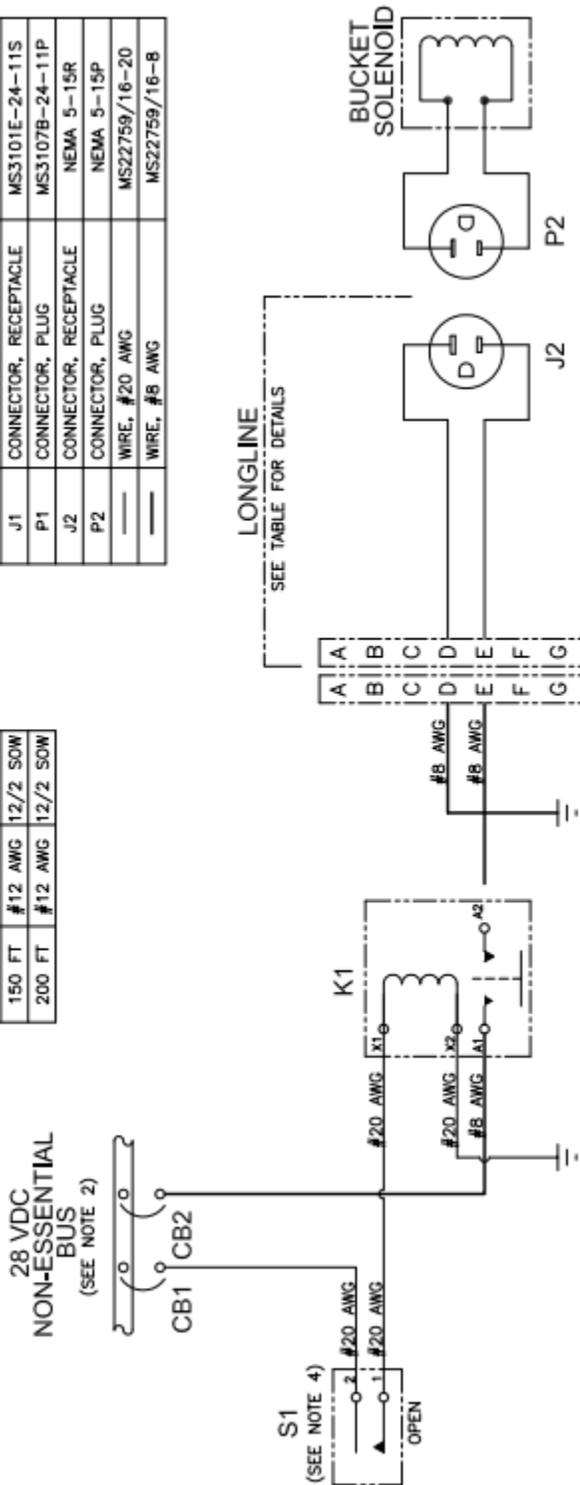

- NOTES:**
1. THESE ARE RECOMMENDED INSTALLATION INSTRUCTIONS ONLY. ALL INSTALLATIONS TO BE DONE BY QUALIFIED PERSONNEL IN ACCORDANCE WITH APPLICABLE LOCAL REGULATIONS.
 2. CONNECTION TO AIRCRAFT POWER SUPPLY DONE IN ACCORDANCE WITH FAA ADVISORY CIRCULAR AC43.13-1B AND AC43.13-2A. DO NOT CONNECT THE BAMBİ SYSTEM TO ANY AIRCRAFT BUS BAR THAT IS USED FOR EMERGENCY OR ESSENTIAL LOADS. AMMEND THE AIRCRAFT ELECTRICAL LOAD ANALYSIS TO ENSURE THAT THE GENERATOR CAPACITY IS ADEQUATE TO OPERATE THE SYSTEM.
 3. ALL GROUNDS, SOLDERED TERMINALS, AND CRIMPED TERMINALS DONE IN ACCORDANCE WITH AIRCRAFT MANUFACTURERS INSTRUCTIONS.
 4. ACTUATION SWITCH MOUNTED ON THE COLLECTIVE PITCH LEVER. SWITCH MARKED "OPEN" AND SPRING-LOADED TO THE OFF POSITION.

Section 10: Drawings

Crew Controls

LONGLINE DETAILS

LENGTH	GAUGE	TYPE
50 FT	#14 AWG	14/2 SOW
75 FT	#14 AWG	14/2 SOW
100 FT	#14 AWG	14/2 SOW
125 FT	#12 AWG	12/2 SOW
150 FT	#12 AWG	12/2 SOW
200 FT	#12 AWG	12/2 SOW

RECOMMENDED COMPONENTS

ITEM	DESCRIPTION	SPECIFICATION
CB1	CIRCUIT BREAKER, 10A	MS22073-10
S1	SWITCH, SPST, MOMENTARY	MS16712-1
J1,J2	CONNECTOR, RECEPTACLE	NEMA 5-15R
P1,P2	CONNECTOR, PLUG	NEMA 5-15P
---	WIRE, #16 AWG	MS22759/16-16

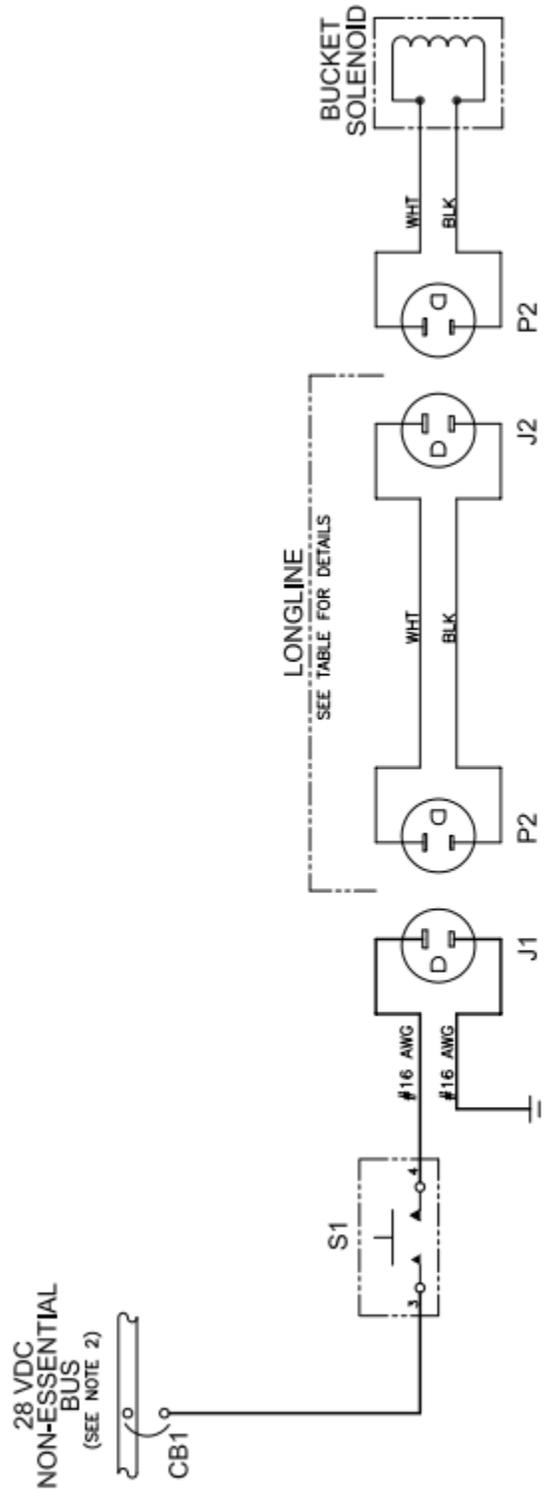

NOTES:

1. THESE ARE RECOMMENDED INSTALLATION INSTRUCTIONS ONLY. ALL INSTALLATIONS TO BE DONE BY QUALIFIED PERSONNEL IN ACCORDANCE WITH APPLICABLE LOCAL REGULATIONS.
2. CONNECTION TO AIRCRAFT POWER SUPPLY DONE IN ACCORDANCE WITH FAA ADVISORY CIRCULAR AC43.13-1B AND AC43.13-2A. DO NOT CONNECT THE BAMBİ SYSTEM TO ANY AIRCRAFT BUS BAR THAT IS USED FOR EMERGENCY OR ESSENTIAL LOADS. AMMEND THE AIRCRAFT ELECTRICAL LOAD ANALYSIS TO ENSURE THAT THE GENERATOR CAPACITY IS ADEQUATE TO OPERATE THE SYSTEM.
3. ALL GROUNDS, SOLDERED TERMINALS, AND CRIMPED TERMINALS DONE IN ACCORDANCE WITH AIRCRAFT MANUFACTURERS INSTRUCTIONS.

Section 10: Drawings

Crew Controls – External Power Supply

RECOMMENDED COMPONENTS		
ITEM	DESCRIPTION	SPECIFICATION
J1,J2	CONNECTOR, RECEPTACLE	NEMA 5-15R
P1,P2	CONNECTOR, PLUG	NEMA 5-15P
—	WIRE, #20 AWG	MS22759/16-20
—	WIRE, #16 AWG	MS22759/16-16

LONGLINE DETAILS		
LENGTH	GAUGE	TYPE
50 FT	#14 AWG	14/2 SOW
75 FT	#14 AWG	14/2 SOW
100 FT	#14 AWG	14/2 SOW
125 FT	#12 AWG	12/2 SOW
150 FT	#12 AWG	12/2 SOW
200 FT	#12 AWG	12/2 SOW

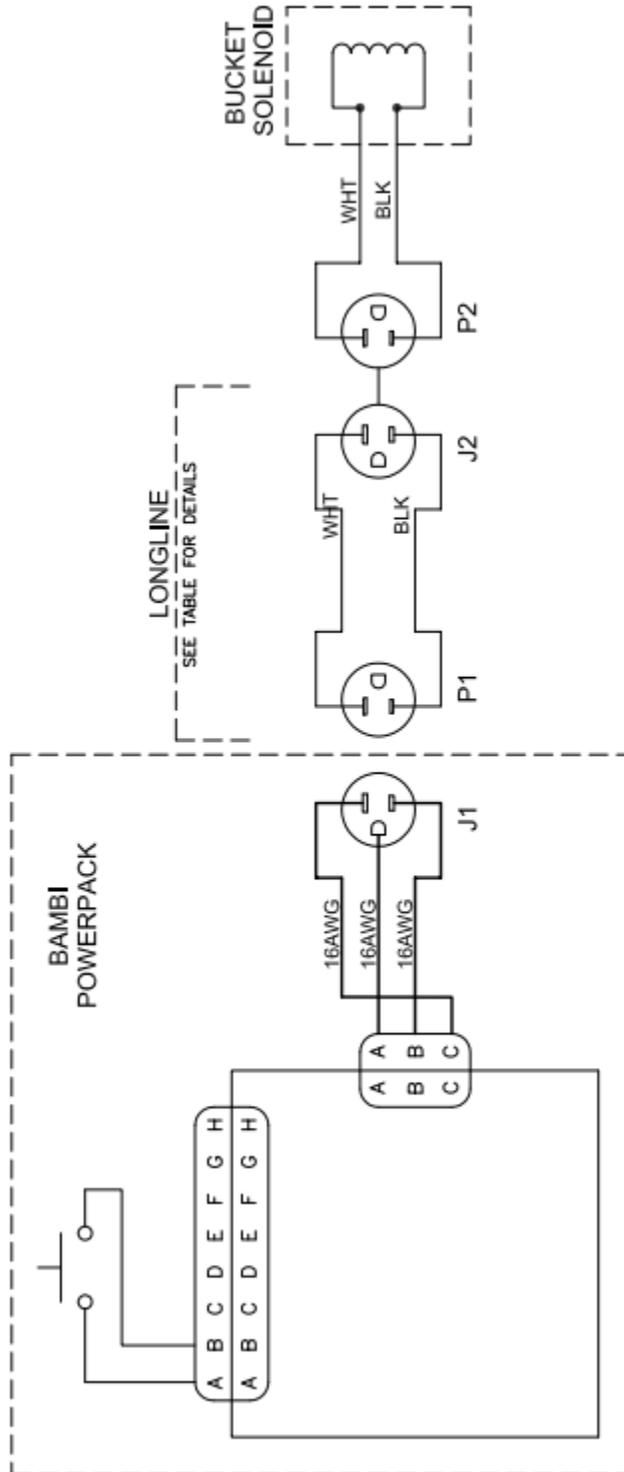

NOTES:

1. THESE ARE RECOMMENDED INSTALLATION INSTRUCTIONS ONLY. ALL INSTALLATIONS TO BE DONE BY QUALIFIED PERSONNEL IN ACCORDANCE WITH APPLICABLE LOCAL REGULATIONS.
2. ALL GROUNDS, SOLDERED TERMINALS, AND CRIMPED TERMINALS DONE IN ACCORDANCE WITH AIRCRAFT MANUFACTURERS' INSTRUCTIONS.

Section 11: Warranty

Section 11: Warranty

SEI Industries Ltd. (the company) agrees to grant a warranty for a period of one year from the date of purchase of Bambi bucket systems on the following conditions:

- a) The company's sole obligation under this warranty is limited to repairing or replacing, at the company's sole discretion, any product shown to be defective.
- b) The company's products are not guaranteed for any specific length of time or measure of service, but are warranted only to be free from defects in workmanship and material for a period of one year to the original purchaser.
- c) To the extent allowable under applicable law, the company's liability for consequential and incidental damages is expressly disclaimed. **The company's liability in all events is limited to and shall not exceed, the purchase price paid.**
- d) This warranty is granted to the original purchaser of Bambi bucket systems and does not extend to a subsequent purchaser or assignee.
- e) The company must receive notification in writing of any claims of warranty from the original purchaser which must give details of the claimed defect in the product.
- f) Where the original purchaser is claiming under warranty, the product must be returned to the company for inspection with all transportation and duty charges prepaid.
- g) In the event the original purchaser does not give notice of a warranty claim, within one year of the original purchase of the product, it is understood that the purchaser has waived the claim for warranty and the purchaser and/or any subsequent purchaser must accept the condition of the product, without warranty.
- h) Any technical information supplied by the company regarding the product is not a condition of warranty but rather is information provided by the company to the best of its knowledge.
- i) There are no implied warranties nor is there any warranty that can be assumed from any representation of any person, except the company itself.

Exclusions

- j) The warranty does not cover damage or failures resulting directly or indirectly from accident, abuse, misuse, or any alteration or modification to the product which has not been specifically authorized in writing by the company.
- k) This warranty does not apply to any accessories used with the product that are not supplied by the company and any warranty on such accessories must be requested from the manufacturer or dealer of the accessories.
- l) This warranty is void if the product is not installed, used and/or maintained in accordance with the operations manual supplied by SEI.
- m) All Bambi buckets are designed and manufactured with substantial safety margins. It is the responsibility of the user to ensure that the bucket is maintained to a safe standard.