



# Technical Bulletin

**Date:** February 19, 2015

**Product Line:** Bambi

**Models:** Sacksafoam I

**Subject:** New Sacksafoam Controller

**Reference:** The new Sacksafoam I manual will be released soon.

<http://www.sei-ind.com/sites/default/files/pdf/2008%20Sacksafoam%20II%20Model%205598%20Manual.pdf>

<http://www.sei-ind.com/sites/default/files/pdf/2008%20Sacksafoam%20III%20Operations%20Manual.pdf>

## Details

SEI is introducing a new Sacksafoam Controller (SFC). This SFC will supersede the original controller for customers with bladder style Sacksafoam I systems. Currently, the new SFC is not directly compatible with Sacksafoam II or Sacksafoam III systems. SEI will continue to provide

the original controller to service Sacksafoam II's and Sacksafoam III's while stock exists.

The SFC is operated with a glove compatible touch screen. The SFC includes an adapter that connects to the existing Sacksafoam wiring harness and includes a D-sub connector that can be used to connect with a remote injection switch. See Figure 2 for details.



*Figure 1 - SFC with DZUS mounts and Adapter*





**Bambi**  
**BUCKET®**  
 Driven by Innovation

DZUS rail adapters are available for the SFC. Please note that the product dimensions have changed and the new SFC will not fit in the same location on a DZUS rail system as the original Sacksafoam controller.

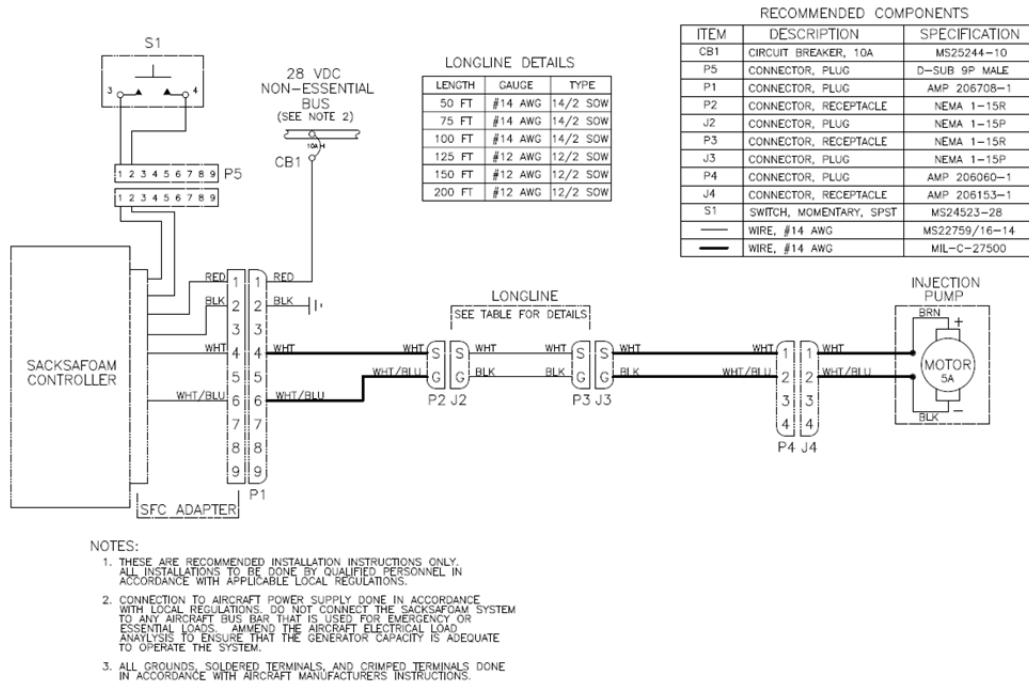

Figure 2- Recommended wiring

This Technical Bulletin is available on the SEI website. <http://www.sei-ind.com/resources/manuals>

For further details, please contact the following SEI representatives.

### Contact

Shawn Bethel  
 Division Manager, Firefighting Division  
 604-946-3131 ext. 119  
[shawn@sei-ind.com](mailto:shawn@sei-ind.com)

Robert Button  
 Product Engineer, Firefighting Division  
 604-946-3131 ext. 423  
[robert@sei-ind.com](mailto:robert@sei-ind.com)



SEI Industries Ltd. 7400 Wilson Avenue, Delta, B.C. Canada V4G 1H3  
 T: 604.946.3131 [seisales@sei-ind.com](mailto:seisales@sei-ind.com) [www.sei-ind.com](http://www.sei-ind.com)